

Airbus technical magazine

March 2018

#61

FAST

Flight Airworthiness Support Technology

A350-900

AIRBUS

Already have the FAST app?

Now get the latest news for customers
via Newsfeed by Airbus.



FAST and Newsfeed by Airbus apps
are downloadable to your preferred device



Airbus technical magazine

#61

FAST

Flight Airworthiness Support Technology



Publisher: Alizée GENILLOU
Chief Editor: Deborah BUCKLER
Design: PONT BLEU

Cover image: Sylvain RAMADIER
Printer: Amadio

Authorisation for reprinting
FAST magazine articles
should be requested by email:
fast.magazine@airbus.com

FAST magazine is available on internet
[www.aircraft.airbus.com/
support-services/publications/](http://www.aircraft.airbus.com/support-services/publications/)
and on tablets or smartphones
ISSN 1293-5476

AIRBUS

© AIRBUS 2018 All rights reserved. Proprietary document

By taking delivery of this Magazine (hereafter 'Magazine'), you accept on behalf of your company to comply with the following. No other property rights are granted by the delivery of this Magazine than the right to read it, for the sole purpose of information. This Magazine, its content, illustrations and photos shall not be modified nor reproduced without prior written consent of Airbus. This Magazine and the materials it contains shall not, in whole or in part, be sold, rented, or licensed to any third party subject to payment or not. This Magazine may contain market-sensitive or other information that is correct at the time of going to press. This information involves a number of factors which could change over time, affecting the true public representation. Airbus assumes no obligation to update any information contained in this document or with respect to the information described herein. The statements made herein do not constitute an offer or form part of any contract. They are based on Airbus information and are expressed in good faith but no warranty or representation is given as to their accuracy. When additional information is required, Airbus can be contacted to provide further details. Airbus shall assume no liability for any damage in connection with the use of this Magazine and the materials it contains, even if Airbus has been advised of the likelihood of such damages. This licence is governed by French law and exclusive jurisdiction is given to the courts and tribunals of Toulouse (France) without prejudice to the right of Airbus to bring proceedings for infringement of copyright or any other intellectual property right in any other court of competent jurisdiction. Airbus, its logo, A300, A310, A318, A319, A320, A321, A330, A340, A350, A380 and A400M are registered trademarks.

Photo copyright Airbus
Photo credits: Airbus Photographic Library, Airbus Corporate Heritage, Master Films, Hervé Gousset, Philippe Masclat, Pascal Pigeyre, Jean-Baptiste Accariez

- ↘ **Engine Bleed Air System** 04
Increasing reliability
with preventive maintenance
- ↘ **A350 XWB composite bonded repair** 10
New technology for new aircraft
- ↘ **Technical data for maintenance** 18
Taking efficiency to new dimensions
- ↘ **A350 XWB vertical stabiliser continuous joint** 26
Precision technology
for attachment fittings
- ↘ **Supporting ageing fleets** 32
Scheduling the unscheduled
- ↘ **FAST from the past** 38
- ↘ **Around the clock, around the world** 39
Field representatives

Engine Bleed Air System

Increasing reliability with preventive maintenance

Article by

Benjamin CALVET

Air and Inerting System Engineer

AIRBUS

benjamin.calvet@airbus.com

By carrying out preventive maintenance on the Engine Bleed Air System, operators can significantly reduce both Operational Interruptions (OI) and costs, as proven over the last five years.

This sub-system draws hot air from the engines, which is then distributed for essential functions such as cabin pressurisation and air intake de-icing.



An overview of the Engine Bleed Air System

The Engine Bleed Air System is a sub-system of the Bleed Air System that is installed directly within the aircraft engine. It allows air to be bled from several engine ports in order to ensure sufficient pressurised air is provided to consumers* which include:

- Engine starting (including cross starting)
- Wing anti-ice system
- Cabin pressurisation
- Fuel Tank Inerting System (FTIS)
- Cabin air generation and cooling systems (ATA21)
- Pressurisation of hydraulic tank, as well as waste and water storage tanks

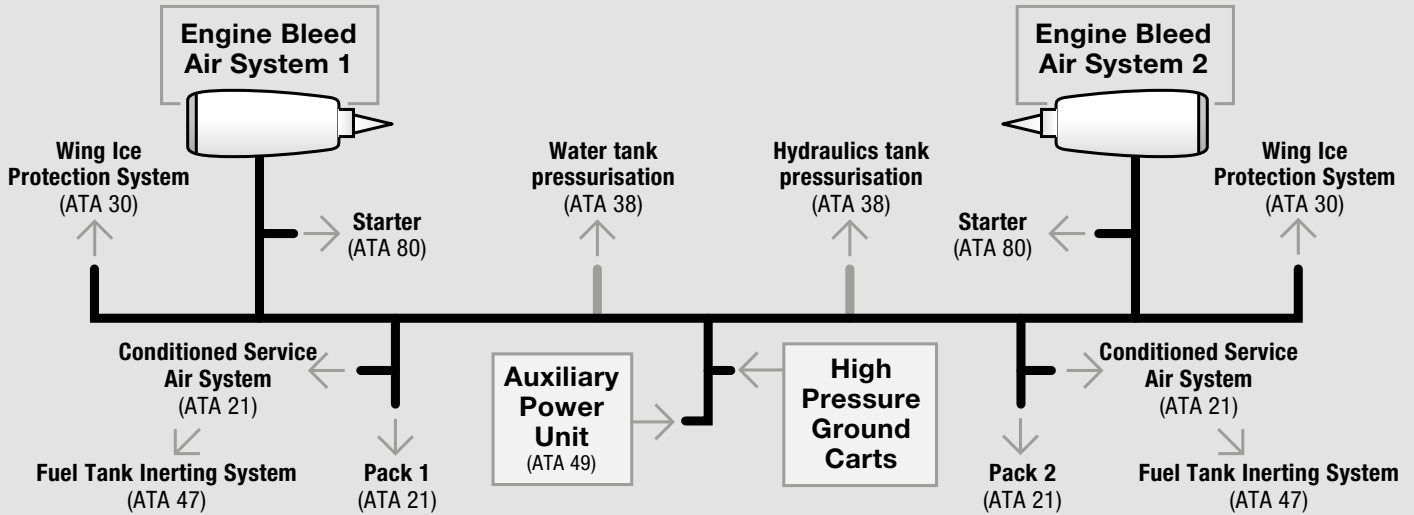

This sub-system provides consumers* with high temperature air (200°C) at high pressure (44 PSI) and has 3 main functions:

- 1 Temperature control
- 2 Pressure regulation
- 3 Pressure control

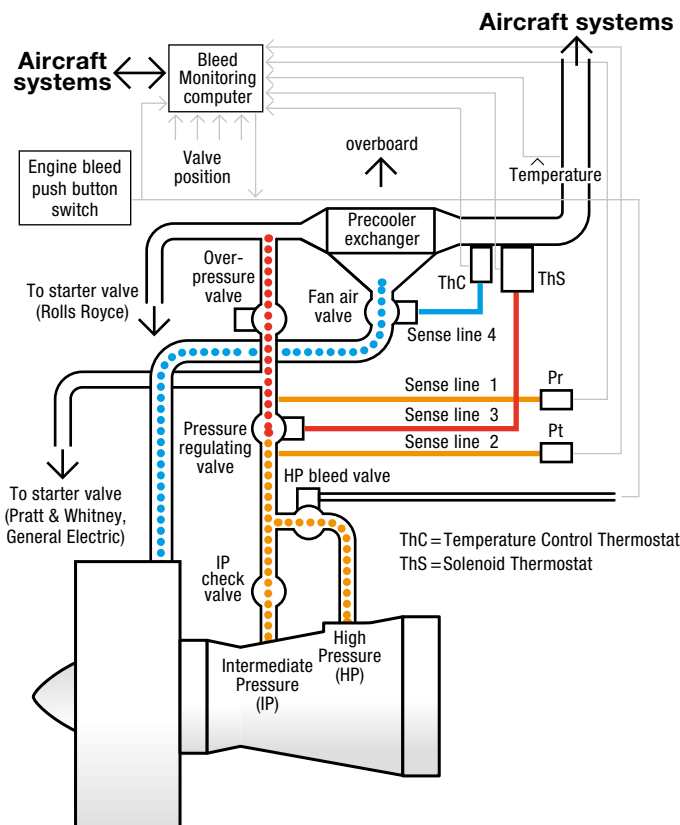

Engine Bleed Air Systems have evolved with each Airbus aircraft programme. Earlier generation families such as the A320ceo and the A330ceo are fitted with full pneumatic Engine Bleed Air Systems whereas more recent programmes are fitted with electro-pneumatic systems.

Airbus aircraft programme	Full pneumatic EBAS	Electro-pneumatic EBAS
A320ceo	X	
A330ceo	X	
A340 basic	X	
A340-500/600		X
A380		X
A350		X
A320neo		X
A330neo		X

* A function which 'consumes' bleed air.

Defining the need

Engine Bleed Air System failures can lead to unscheduled maintenance with associated operational interruptions, as well as to severe events such as in-flight turn-back or diversion due to loss of cabin pressurisation capability.

Initially, design improvements were introduced on the full pneumatic bleed systems used on early generation families (A320ceo, A330ceo and A340 basic). However, given the impact of bleed systems on operational reliability, a solution was required to counter-balance performance degradation due to bleed component ageing.

Preventive maintenance for the full pneumatic Bleed Air System on A320ceo aircraft was first discussed several years ago, between airlines and Airbus, with the creation of a dedicated FAIR (see insert) working group for single aisle aircraft. This discussion involved airlines who expected to have dedicated preventive maintenance on the Engine Bleed Air System. The programme was required to address all Airbus aircraft fitted with full pneumatic Bleed Air Systems and to involve only limited investment by airlines.

Finding the solution : Engine Bleed Check

Based on the above requirements, Airbus and Liebherr (valve supplier for engine manufacturers) developed a preventive maintenance programme to detect a drift in the system's functions before a fault is triggered. The Engine Bleed Check preventive maintenance programme was created. To validate the efficiency of this solution, it was tested on both the A320ceo and A330ceo.

This preventive maintenance was first introduced in 2012 on the A320ceo, and then on the A330ceo and A340 basic. Airbus and Liebherr worked closely together to define relevant tests and criteria at system and equipment level, based on incident reporting provided to Airbus from customer workshops. The check tests the three main functions of the Engine Bleed Air System:

- **Temperature Control**
- **Pressure Regulation**
- **Pressure Control**

The procedures used to perform these tests have been implemented in the Aircraft Maintenance Manual. Each procedure has been designed to use only test ports and the deactivation screw of the valves, to test the defined sub-system functions while avoiding the removal of components.

In addition, dedicated thresholds have been identified to detect drift in each function and then schedule the corrective action necessary to redress the drifts. Additionally, these thresholds are also defined so that any equipment that is removed for testing in shop will be confirmed faulty. The degree of precision offered by the check avoids needlessly removing and sending equipment for verification, only for it to be returned as No Fault Found.

However, it is important to highlight that the Engine Bleed Check should not be considered as part of a troubleshooting solution following a failure. Dedicated troubleshooting tasks should be applied when a fault is triggered.

FAIR

Airbus' **Forum with Airlines for Interactive Resolution**, where airlines share their experience on dedicated topics.

If an airline is affected by a specific issue, it posts a new item for further discussion with other airlines.

Airbus regularly screens the item and provides development updates.

The Engine Bleed Check helps prevent unexpected operational incidents by detecting initial deviations and enabling scheduled maintenance

Airbus Bleed Test Set and associated kit for Engine Bleed Check

PN 98L36103002000



SBE2213

PN M82000678

What tools are needed to perform this preventive action?

As stipulated by the airlines, their investment to implement this preventive maintenance had to be limited. With this in mind, the main tool required for the check is the Bleed Test Set that is already used for troubleshooting.

Two troubleshooting Bleed Test Sets are proposed, one supplied by Airbus and the other supplied by Liebherr. The tools are the same for the A320ceo, A330ceo and A340, and AMM procedures have been designed to be applied using the two proposed Bleed Test Sets. In addition to these, several adaptors are also necessary to perform tests. The table to the right shows all the tools necessary to implement the Engine Bleed Check.

Both Airbus and Liebherr sets are available through the Airbus Spares portal for customers.

	Airbus set	Liebherr set
Bleed Test set ● ● ●	PN 98L36103002000	PN 99127B03
Liebherr Bleed Test set kit ● ● ●		A320 Family: 99127-231 A330 Family: 99127-241 A340 basics: 99127-251
Liebherr Universal Test Port ● ●		PN M82000678
Sense line tester ● ● ●	SBE2213	

● Temperature control ● Pressure regulation ● Pressure control

How often should tests be performed?

Based on a worldwide fleet study taking into account both fleet experience (Operational Interruption main drivers) and components experience (MTBUR/ MTBF*), the typical interval for Engine Bleed Checks should be 18 months for A330ceo Family aircraft and the A340 basic, and 20 months for A320ceo Family aircraft. However, this interval can be adapted by each airline depending on their key Engine Bleed Air System OI drivers.

In addition, procedures have been designed to be as adaptable as possible. They allow airlines to perform one test of a given function and on one engine, rather than performing the full set of tests on all engines. This adaptability allows airlines to implement the Engine Bleed Check depending on their experience. The time required to perform one task is approximately two man hours.

* **MTBUR** Mean Time Between Unscheduled Removals

MTBF Mean Time Between Failures

What procedures are available?

All procedures for the A320ceo, A330ceo and the A340 basic are already available through AMM tasks that are quoted in the below tables:

Temperature Control	AMM task ref. using Liebherr Bleed Test set	AMM task ref. using Airbus Bleed Test set
A330 GE	36-11-00-720-809-A	36-11-00-720-809-A01
A330 PW	36-11-00-720-812-A	36-11-00-720-812-A01
A330 RR	36-11-00-720-815-A	36-11-00-720-815-A01
A340	36-11-00-720-821-A	36-11-00-720-821-A01
A320	36-11-00-720-802-A	36-11-00-720-802-A01

Pressure regulation	AMM task ref. using Liebherr Bleed Test set	AMM task ref. using Airbus Bleed Test set
A330 GE	36-11-00-720-810-A	36-11-00-720-810-A01
A330 PW	36-11-00-720-813-A	36-11-00-720-813-A01
A330 RR	36-11-00-720-816-A	36-11-00-720-816-A01
A340	36-11-00-720-823-A	36-11-00-720-823-A01
A320	36-11-00-720-804-A	36-11-00-720-804-A01

Pressure control	AMM task ref. using Liebherr Bleed Test set	AMM task ref. using Airbus Bleed Test set
A330 GE	36-11-00-720-811-A	36-11-00-720-811-A01
A330 PW	36-11-00-720-814-A	36-11-00-720-814-A01
A330 RR	36-11-00-720-817-A	36-11-00-720-817-A01
A340	36-11-00-720-822-A	36-11-00-720-822-A01
A320	36-11-00-720-806-A	36-11-00-720-806-A01

Recommendations in case of findings

If the check detects a drift from the dedicated thresholds of each function, additional tests may be required to determine the root cause. Correcting this drift is advised to ensure system operations until the next check.

The suspected component may be replaced immediately or at the next opportunity.

Findings resulting from the check are not subject to immediate troubleshooting prior to dispatch. Operational considerations remain linked to the BMC monitoring logics (ECAM warning, maintenance status) and associated MMEL/TSM coverage.

Based on the above, component removal can be scheduled at a later convenience while monitoring the system's drift through Class 3** messages.

Finally, components that are removed during this preventive maintenance programme should be sent for CMM test & repair. It is highly recommended to tag the reason for removal as "check removal" and to mention the paragraph of the AMM failure. Supplying this information will ensure the correct reason for removal and will help determine the appropriate repair of the component before return into service.

AMM Aircraft Maintenance Manual

BMC Bleed air Monitoring Computer

CMM Component Maintenance Manual

ECAM Electronic Centralised Aircraft Monitor

MMEL Master Minimum Equipment List

TSM Trouble Shooting Manual

** **Class 3** messages are of low urgency

Class 2 messages should be dealt with within 800 Flight Hours

Class 1 messages are urgent, possibly NoGo, AOG



Engine Bleed Check workshop

To implement the Engine Bleed Check, customers can sign up for a workshop, in the Engineering Workshop portfolio in the AirbusWorld Customer Services e-catalogue.

This workshop comprises:

- Classroom sessions to review how the Engine Bleed Air System works
- A specific review of Operational Interruptions experienced by the airlines and how to troubleshoot them
- Demonstrations on an aircraft, of how the Engine Bleed Check procedures should be applied and the aim of each test done during the Bleed Check

Several airlines have already benefited from this service, finding it useful and efficient, enabling them to reinforce their knowledge of the bleed air system and of preventive actions to reduce the number of Operational Interruptions.

CONCLUSION

The Engine Bleed Check is a preventive maintenance programme for the A320ceo, A330ceo and A340 basic. It assesses the robustness of the full pneumatic Engine Bleed Air System by detecting any drift of the main system functions before failure. It allows airlines to schedule engine bleed air maintenance and to increase operational reliability of the system.

This solution has been implemented through AMM tasks and uses existing tools. Tasks can be carried out during scheduled checks and the intervals proposed by Airbus can be adapted depending on the airline's experience. Performing each task takes around two man hours.

The efficiency of this solution has been proven, and feedback received from airlines indicates that the operational reliability of Engine Bleed Air Systems has considerably improved, and is no longer a major concern since the introduction of this preventive maintenance.

Finally, to support airlines in Engine Bleed Air System Check implementation, Airbus has deployed an engineering workshop including a demonstration on an aircraft. ■■■

For more information related to this workshop contact customerservices.consulting@airbus.com.

A350 XWB composite bonded repair

Article by (left to right)

Sébastien HANSER
Embodiment Industrial Manager
AIRBUS
sebastien.hanser@airbus.com

Guillaume FERRER
Embodiment Industrial Manager
AIRBUS
guillaume.ferrer@airbus.com

Sébastien DUPOUY
Embodiment Industrial Manager
AIRBUS
sebastien.s.dupouy@airbus.com

New technology for new aircraft



Even if composite repairs are not new at Airbus, the extensive use of Carbon Fibre Reinforced Plastic (CFRP) on the A350 XWB and especially on primary non-removable parts, is driving the development and the industrialisation of new composite-specific repair solutions.

Over the last two decades, generic solutions were used for damaged composite components. Most of the affected parts were removable and located in non-pressurised areas. The new challenge was to repair primary structures without removing them from the aircraft and with minimal grounding time. The solution had to restore the required structural capabilities, be carried out on-site, and bring the exterior skin of the aircraft back to its original flush finish.

What is CFRP?

The primary structure of the A350 XWB (Extra Wide Body) is of Carbon Fibre Reinforced Plastic (CFRP). This composite has progressively replaced aluminium in aircraft design over the past years, improving performance (less weight for the required structural robustness), but also bringing benefits such as increased resistance to impacts, simplified damage assessment processes and proven repair solutions.

(See article in FAST#57)

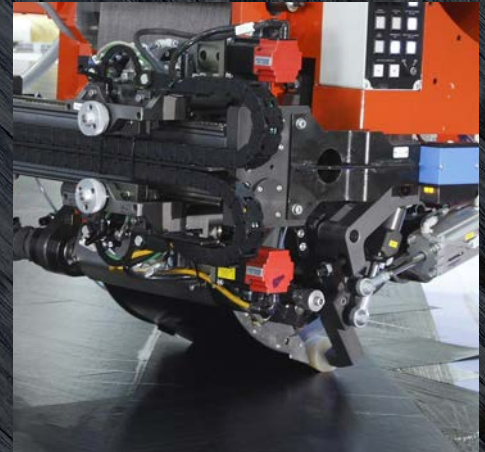

Combining legacy and advanced innovative solutions

Different repair solutions exist, from the traditional bolted metallic doubler, to the most advanced out-of-autoclave, on-wing, bonded repair. The 'best-fit repair' principle is used to select the choice of repair solution depending on the stress requirements of the damaged area: if the damage affects structural elements, then a metallic bolted solution or a bonded repair are the preferred methods.

Airbus uses its wide experience in building and repairing composite structures to advise on the most appropriate solution to specific damage and repair scenarios, based on the new requirements presented by the A350 XWB structure. Bonded repair is adapted to customers' specific requirements and expectations, and in accordance with airworthiness conditions.

Adapting the repair type to the situation

The main drivers are always safety and lead time. The three composite repair techniques available give different aerodynamic and aesthetic finishes:

Quick but temporary bolted metallic doubler

This will certainly fix an AOG situation, bringing the aircraft back to service very quickly and safely. After a grace period (life limitation), this efficient but visible non-flush repair (external doubler) has to be replaced by a permanent repair.

Permanent bolted pre-cured CFRP repair (but not flush)

This is a permanent pre-cured CFRP doubler without any additional cosmetic or aerodynamic consideration.

Permanent bonded flush repair

Most commonly experienced in-service damage, such as severe lightning strikes or GSE impacts, can be repaired using the bonded method, enabling on-site repair with a flush finish.

A complex repair, mixing bolted and bonded techniques



A bonded repair... from start to finish



1)

Damage assessment

Before any engineering decision or repair action, a very precise assessment is carried out, described and recorded in a damage report.

Specific Non-Destructive Testing (NDT) equipment has been developed for operational repair on the A350 XWB such as the Line tool, Line sizing or Line mapping tools. These enable clear identification, localisation and characterisation of the damage.

As the fuselage skin is a monolithic structure (a solid laminate composite – see glossary), the NDT means that are used are mainly ultrasonic detection such as A-Scan and C-Scan phased array. (see FAST 57 for more information on CFRP damage and NDT methods).

This assessment stage is essential for communicating precisely with engineering teams and defining a fast and safe repair solution.



2)

Damage removal

Once the repair definition is established, the working party team removes damaged plies (layers) following a very precise pattern. The damaged area is removed by cutting the CFRP skin using a high-speed, diamond-coated cutter.



3)

Stepping design for bonded repair

The area in which the bonded repair is to be applied is progressively sand-stepped or removed using a new system: The Repair Jet®. The system, which has been specially developed and qualified for the A350 XWB, uses pressurised water that contains an abrasive media. The portability of the Repair Jet® allows it to be used in areas where the repair's situation and ergonomics make it difficult or uncomfortable to perform (lower shells, overhead working).

This process combines a precise set of parameters (pressure, speed, nozzle design, media type...) to obtain the final result (consistent depth machining).

Sand-stepping requires a high level of experience to match the design engineering requirements (tolerances, orientations, ply numbers).

The Repair Jet® allows clean and safe machining; the pressurised water means that no carbon dust is generated, and that temperature is not elevated, while the high precision of the jet avoids ply delamination that can occur with other methods of machining.

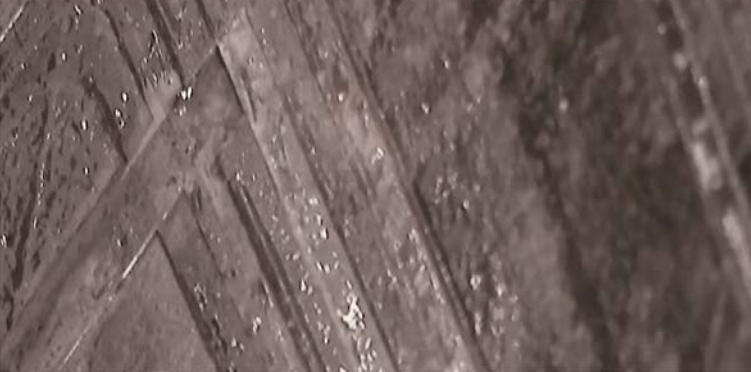

4)

Surface preparation

Once the stepping has been completed, it is cleaned for optimal bonding. An aircraft's environment often presents elements that could contaminate the bonding process such as fuel, hydraulic liquids, mineral oil or wax. Using specific solvents the operator chemically prepares the surface removing all sources of contamination that could lead to misbonding.

5)

The water-break test

This test consists of applying a small quantity of water onto the prepared surface (bonding area) and checking its physical behaviour. The cleaning operation is repeated until the water forms a continuous film on the surface to be repaired.

The aim of this test is to ensure the required cleanliness and roughness of the surface required for optimal bonding.

6)

Thermal profile

To secure the final curing cycle, the thermal profile defines the homogeneity of the repair zone cure cycle by controlling the thermo-couples which are located at the edge of the repair zone. A dummy patch (representative of the repair patch) is then placed in the repair area, using a release film to avoid the dummy from bonding. This dummy is equipped with thermo-couples to record thermal mapping of the dummy and its relevant bonding line.

This task is a dry-run for curing, which validates the quality of the vacuum bag thermal insulation.

7)

Repairing with pre-impregnated materials and film adhesives

An adhesive film is placed into the whole prepared surface (including the stepped area) before positioning the pre-impregnated fabric or tape plies; the type of adhesive used depends on the curing cycle and required thickness*.

Repair plies (fibres) are generally similar to the parent structure, associated with a pre-impregnated resin dedicated to repair solutions. These are laid out following the original orientation and the stepped machining provides sufficient overlap to enable load transfer between the existing structure and the repair patch.

The repair kit is prepared in a clean room which is located as close as possible to the repair area.

This phase is key to restore the structural integrity of the component or the structure.

**Another advantage of CFRP is that extra layers of composite can be applied to areas that take more stress or are susceptible to in-service damage (eg. door surrounds).*

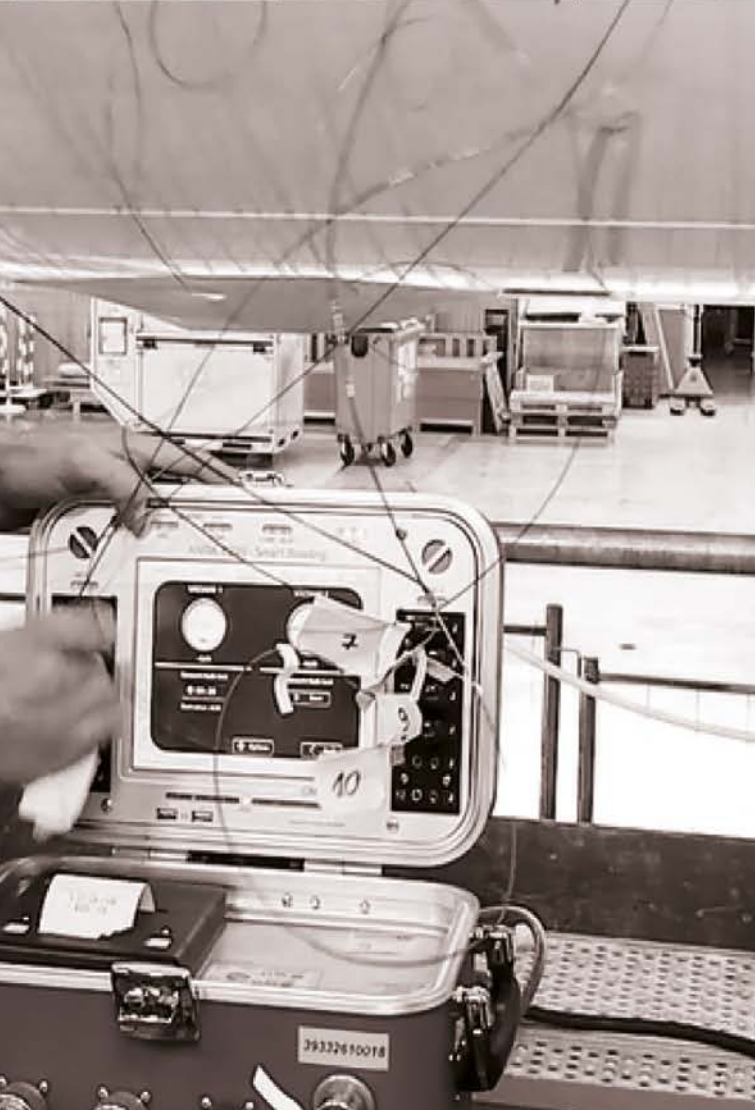

8) Compaction

A compaction phase is used to consolidate cohesion between the plies and to remove air bubbles before the final curing cycle.

This consolidation is another important phase during the 'out-of-autoclave' repair process, as the repair will be submitted to less pressure than traditional 'in-autoclave' manufacturing or repair processes.

9) Vacuum bagging (internal/external)

A vacuum bag is installed to maintain pressure on the plies during the curing cycle. In a case where damage has perforated the skin, a vacuum bag on both sides ensures vacuum communication and tightness. Auxiliary material such as vacuum bag, backing plate, breather fabric and peel plies* are defined by the Aircraft Structure Repair (ASR) instructions.

Vacuum bagging

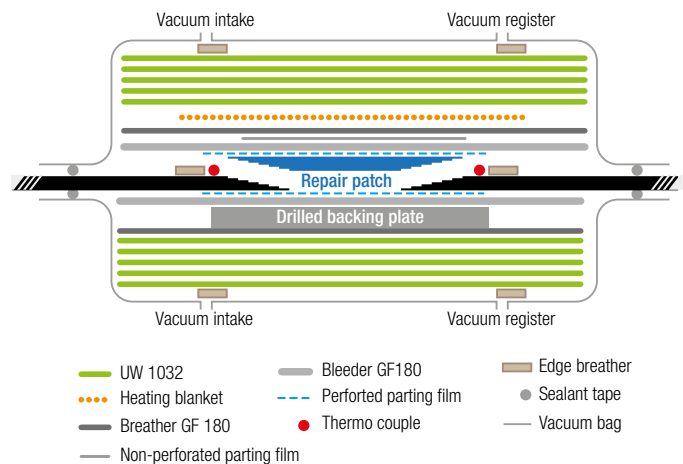

10) Cure cycle

The cure cycle for a repair corresponds with the processing window that is appropriate for each material as indicated in its corresponding Airbus specification. When more than one material is included in an area (adhesive film, pre-impregnated fibres ...), the selected cure cycle must cover the processing window of all of them. A specific curing cycle involving 2 temperature stages has been developed in order to reach the required 140°C.





11)

Restoration of lightning strike protection

Expanded Copper Foil (ECF) which ensures the electrical bonding protection against lightning strikes is integrated within the original fuselage composite of the A350 XWB. During the composite bonding repair this electrical continuity is re-instated by overlapping the original ECF with a new ECF patch.

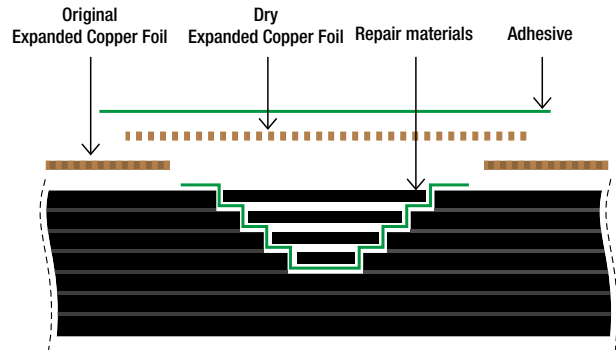

12)

Internal bolted repair embodiment

Damaged internal structure is restored by observing the repair definition given by Airbus design engineering, following generic repair principles proposed in the ASR manual.

On most occasions these principles use spliced pre-defined standard spare parts, that are bolted to the CFRP.

Specific drilling tools and processes must be used to install pre-cured parts (stiffeners, clips, solid shims or internal doublers). Each part that has been freshly cut (according to the repair definition) must have its edge sealed to prevent galvanic corrosion (Aluminium/CFRP).

13)

Final post repair inspections before return to service

Before return to service, the repair area must be inspected using standard NDI technics given in the Non-destructive Testing Manual (NTM) and the ASR manual for the A350 XWB.

Both visual and ultrasonic (C-scan phased array) inspection methods are performed according to the repair documentation's indications.

14)

System and internal equipment re-installation

After completion of the structural repair, any systems and equipment that needed to be removed in order to access and repair the interior of perforating damage, are then re-installed by the working party's systems specialists, following Aircraft Maintenance Manual (AMM) and ASR specific tasks.

Repair on a flight test aircraft

Capability demonstration of a combined repair on a flight test aircraft.

The bonded repair process has undergone a 3-year certification campaign, during which the pyramid of destructive and non-destructive tests ensured that the bonded CFRP repair would withstand stress levels well beyond those in a real life, operational situation.

In addition, an Airbus working party then applied this repair technology to a flight test aircraft in Toulouse, France.

Using a realistic scenario the repair team assessed and repaired the damage, combining skin bonded repair & stringer bolted repair.

This innovative combination of best-fit repair principles addressed structural, aesthetic and aerodynamical constraints.

Carrying out a repair

It is important to note that each type of repair requires specific training. In the case of bonded repairs, there are three levels of knowledge depending on the type of repair: Cosmetic, Advanced and Expert.

Operators can use Airbus working parties to carry out all levels of repair. Further information on CFRP bonded repair training courses can be found on AirbusWorld > AIRTAC > Airbus Engineering



GLOSSARY

Monolithic structure

This is a solid laminate composite such as CFRP as opposed to carbon fibre composite/honeycomb sandwich structures.

Peel ply

A layer of open weave material, usually polyester, fibreglass or heat-set nylon, applied directly to the surface of an uncured prepreg or wet lay-up. It protects the surface to be bonded from contamination during manufacturing or repair operations. The peel ply is removed from the cured laminate immediately before bonding operations, leaving a clean resin-rich surface that needs no further preparation for bonding, other than application of a primer where one is required.

CONCLUSION

Airbus is constantly developing and improving repairability of its aircraft, proposing a set of innovative repair solutions, special tooling and associated training.

With the arrival of Carbon Fibre Reinforced Plastic, widely used on the A350 XWB, technology has evolved bringing an additional repair solution to match this material. Depending on the type of damage incurred, but also on the result required in terms of lead-time and aesthetics, customers can now choose from three types of composite repairs, from bolted metallic doubling to bolted pre-cured or bonded flush repair. ■■■

Technical data for maintenance

Taking efficiency to new dimensions



With an ever-increasing responsibility to ensure safe and efficient maintenance operations within tighter lead times, the customer's need for digitised technical data has never been greater.

Customers expect high quality maintenance documentation with easy access, an intuitive interface and fast updates.

Airbus is investing in new technologies, to supply maintenance and engineering data not only in real-time, but to new levels of detail that enable quicker and more precise operations.

Article by

Boris PLOTEAU
Customer Contract and Policy
Manager Technical Data
AIRBUS
boris.ploteau@airbus.com

In recent years, the escalation of commercial flights has put pressure on all aeronautical stakeholders to optimise their maintenance operations:

- **Reduced Turnaround Times have become key to an airline’s profitability, and aircraft mechanics have less time to access, consult and interpret maintenance documentation.**
- **Airworthiness authorities have become increasingly involved in maintenance documentation, and regularly audit Airbus processes of authoring, generating and delivering maintenance and engineering data.**

As Type Certificate holder, Airbus provides its operators with Instructions for Continued Airworthiness (ICA) to ensure compliance with EASA Part 21J, a requirement for Design Organisations Approvals (DOA). Airbus defines and delivers configured ICA when an aircraft is delivered and then continues to update the ICA throughout its entire operational life.

In the first half of 2018, and based on a new EASA regulation, Airbus will designate some ICA (e.g. AMM, IPC, ESPM and NTM), approved under DOA process.

This new regulation does not impact Airbus customers but entails even stronger regulatory requirements concerning Airbus processes for data authoring and validation. Customers in general will benefit from the approved nature of an Airbus ICA when justifying an aircraft’s release under Part 145 to their National Airworthiness Authorities.

Upon request, any National Airworthiness Authority can obtain access to Airbus’ maintenance and engineering data that is applicable to an aircraft registered with them.

- **At delivery, customers are increasingly involved in maintenance and engineering data to ensure everything they need is available right from day one of operations.**

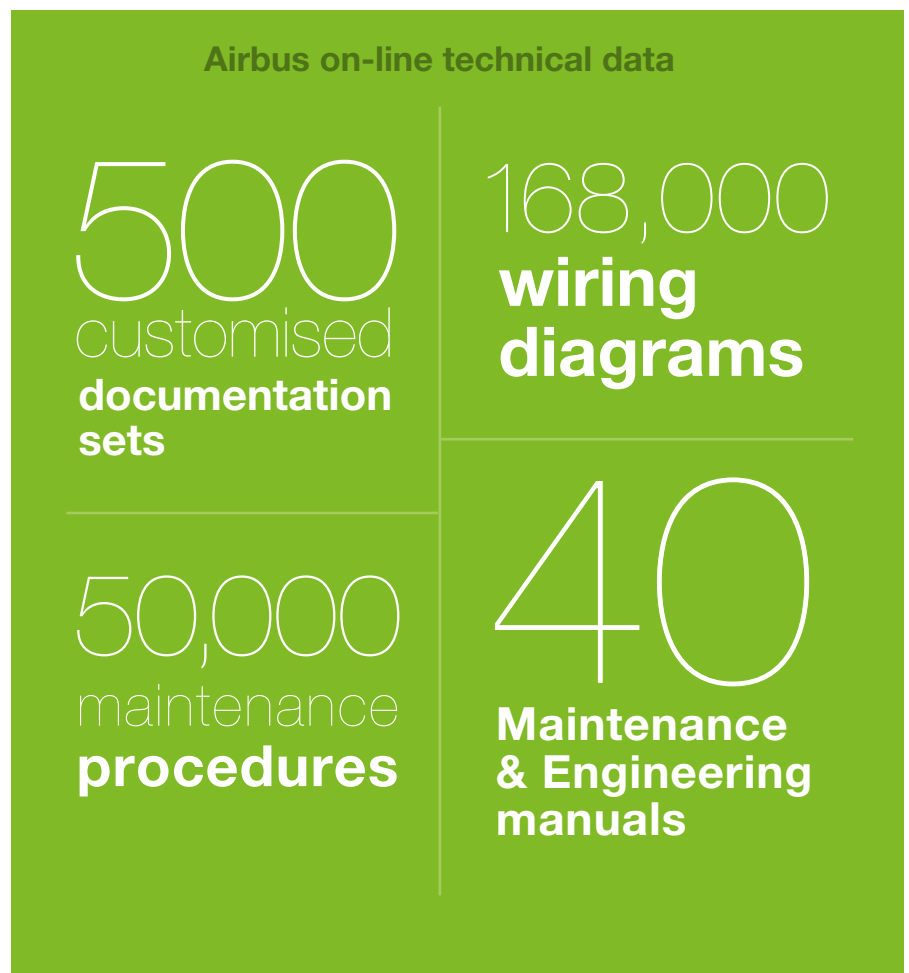

Managing more information in less time

Before moving to full online delivery of technical data, Airbus used to deliver over 250,000 CDs or DVDs every year. Operators can now choose to download data via a secure web-based interface, which both speeds up data delivery and reduces the global CO₂ footprint.

Today, Airbus customers access, consult and download data using the customer portal, AirbusWorld, and do not receive any physical media. Customers can access the portal via all devices and manage their documentation, customising the interface by selecting specific aircraft and specific systems by ATA chapter. They can also customise the AirbusWorld homepage to their own needs and methods of working as well as manage and control the different databases used in their own intranet environment. Consulting and downloading maintenance data from AirbusWorld is done with one dedicated application: airnav^x.

airnav^x entered into service in April 2017, enabling the end-user to access and download maintenance data, PDF manuals and software by simply using the browser's "Save as" function. Thanks to its simplicity the application has a high level of reliability with no disruption.

A customer panel works with Airbus to test and develop new solutions, with 25 customers having participated in the development of airnav^x. From the second half of 2018, customers will join the collaborative approach by using 3D animations, images, videos and other smart media for aircraft maintenance on an online platform.

**Access technical data
more efficiently**

airnav^x

Customers handle a continuously increasing volume of information while having less time in which to process it.

Airbus now offers airnav^x as a reliable, fast, easy-to-use and efficient application to list, download, browse and search Airbus technical data, without relying on external browser plug-ins.

In the long term, airnav^x will replace over ten existing applications. It is being deployed gradually, the first step being the entry-into-service of airnav^x My Library on April 2017.

airnav^x My Library offers one single access point to list and download Airbus technical data (maintenance, engineering and flight operations), as well as to browse specific flight operations PDF documents.

The airnav^x browsing function completes the scope of airnav^x My Library with additional features to search and browse the data, with a troubleshooting function to retrieve the aircraft fault isolation procedure.

airnav^x covers maintenance operations on the A380, A350 XWB, as well as A320 and A330/A340 families, and replaces the following AirN@v products:

- AirN@v / Maintenance
- AirN@v / Line Maintenance (A350 XWB)
- AirN@v / Repair
- AirN@v / Associated data

In 2018, the scope of airnav^x will be progressively extended.

Aircraft maintenance
technical data

Ensuring up-to-date technical data

Customers can log all technical queries in the TechRequest application, which enables traceability and follow-up by Airbus and selected suppliers. The requests are analysed and answered in this application.

At the same time, Airbus uses this customer feedback to launch maturity initiatives to detect major and/or recurring issues within the technical documentation. Its static and flight test teams use the maintenance data to detect and correct any issue prior to the delivery of data to the operator. This helps in improving the completeness and accuracy of maintenance and engineering documentation.

Airbus updates forthcoming documentation for all impacted aircraft as required and may provide the operators concerned with an update in advance, prior to the next revision, avoiding re-occurrence of major issues.

- **Troubleshooting manuals** now incorporate any maintenance advice quoted in technical information documents, such as the Technical Follow-Up document.
- **Aircraft Maintenance Manuals** have been optimised to include procedures coming from part suppliers, within Airbus' procedure. The present focus is to include procedures that relate to unscheduled maintenance operations.
- **Structural Repair Manual** has changed to a task-oriented layout, in order to allow direct access and simple navigation to the repair procedure. Weight variant information has been reviewed to show only the most conservative variant.
- **Airbus Illustrated Parts Catalogue** has been simplified to show only two types of message for part interchangeability: 'spares', for direct interchangeability or 'conditional spares', requiring a condition to be met or where mixing of the same part numbers is not allowed.
- **Airbus maintenance documentation** is customised for each individual aircraft. Cabin and cargo information is by nature highly customised.

To adhere to the new reinforced regulatory requirements, Airbus also optimises the content of the Aircraft Maintenance Manual and the Illustrated Parts Catalogue documents for an efficient aircraft entry-into-service. This optimisation includes exceptional revisions in addition to the contractual regular revisions.

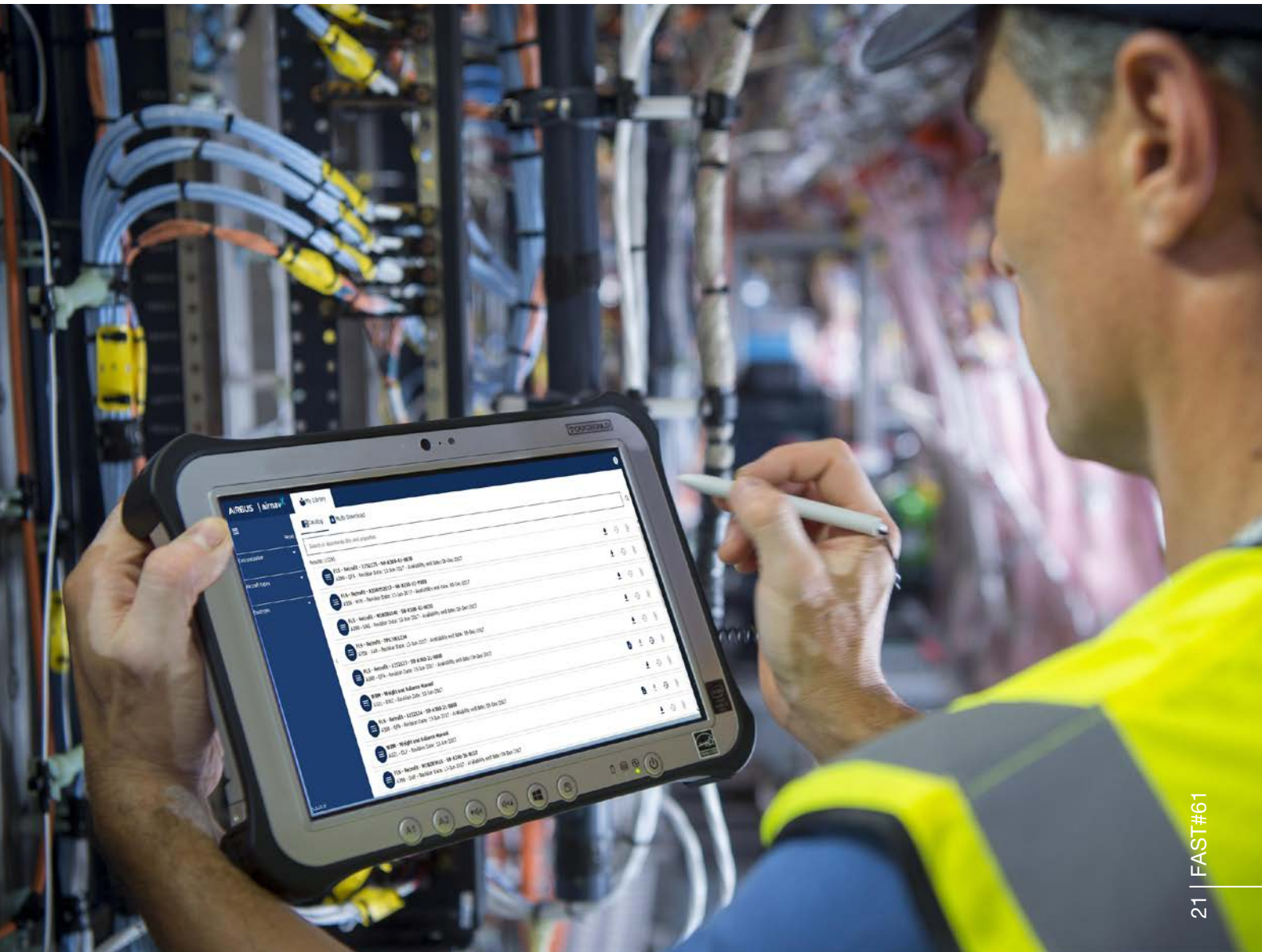

Share smart media for aircraft maintenance

airnaveo

airnaveo is an on-line collaborative platform to share smart media, videos, 3D data, and images for aircraft maintenance. This application will be available on AirbusWorld and linked to the airnav^x browser.

From a maintenance procedure, for example, the end-user will have a media icon that opens a page with all available smart media configured and applicable to this task. Videos from Airbus engineering departments, describing the real maintenance use case, images and all 3D animations will be available. Customers can then load their own smart data into Airbus' database. Airbus moderates the data which may subsequently be shared with other customers.

Airbus is working with certifying authorities to allow this data to become Airbus Instructions for Continued Airworthiness.

The pilot phase is planned for mid-2018.

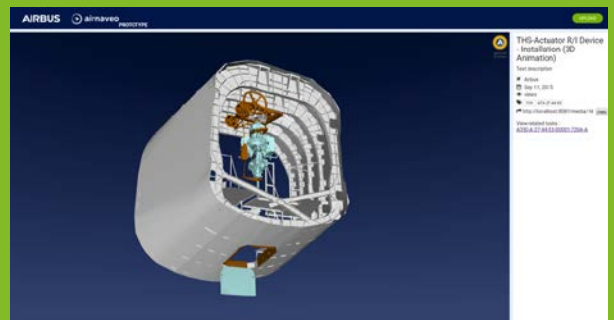
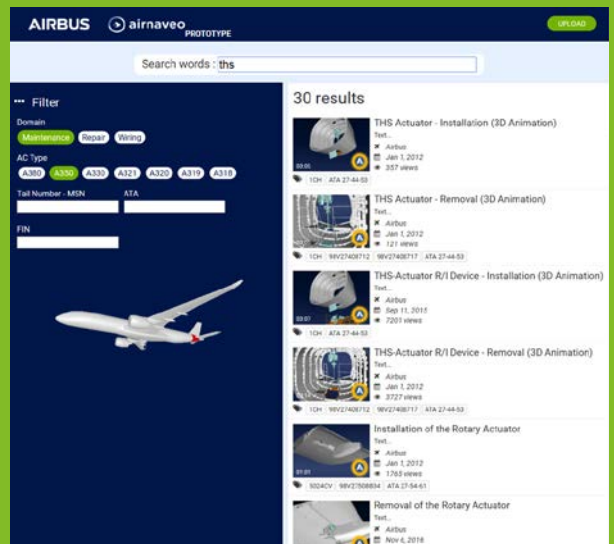

Developing reliable, cost-efficient IT

Customers currently download and install maintenance and engineering data into their IT environment, allowing them to share data internally, create Job Cards, attach airline proprietary documents and re-author or customise Airbus data.

This data management often generates significant IT investments for operators. Airbus' aim is to reduce these investments by maintaining a high level of availability of the AirbusWorld portal, using duplicated Airbus servers and a worldwide Content Delivery Network.

Future developments will include the ability to attach external documents, for example engineering orders, and the option to edit data within Airbus' online applications.

All these investments will allow the vast majority of Airbus operators to fully integrate their IT environment online with AirbusWorld.

Establishing industry standards for data exchange

Airbus is actively participating in the development of the Civil Aviation Technical Data Exchange standards, ATA Spec 2000, 2400 and 2500.

These standards allow aviation actors to build a single system for data coming from different sources, establish a stable and agreed interface between the data supplier and the data consumer, larger tool choice for users and lower cost for the whole industry.

The data exchange standards are already being integrated into Airbus processes and services. An example of this is Service Bulletin (SB) reporting. Maintenance data is kept complete and up-to-date by the operator reporting the embodiment of Service Bulletins to Airbus. Aircraft operators used to record the embodiment in their Maintenance Information System (MIS) and then report embodiments to Airbus via a specific application. The new standards mean that Airbus can better interpret data from the MIS configuration chosen by the customer and facilitate automated Service Bulletin reporting.

Aircraft maintenance technical data

From periodic to real-time updates

Airbus revises and delivers the main maintenance manuals every three months, with A350 XWB and A380 manuals revised every month. Regular revision is especially important during the aircraft delivery period; by mid-2019, Airbus plans to also revise the maintenance data every month for A320 and A330 families. After the aircraft delivery period, the customer can decide whether to maintain a monthly revision cycle or have quarterly revisions.

The next generation of Airbus documentation will provide real-time technical data. Instead of periodic revisions, Airbus will update an online technical data repository as and when the revision of data occurs or when an Airbus Service Bulletin (SB) has been reported. This will allow customers to extract the latest version of the data at any time via a web application.

Airbus will start to implement this type of data access with wiring information. From one online application, the end-user will be able to generate a complete electrical wiring schematic, configured to the aircraft and completely replacing the Wiring Diagram Manual. This new application, called GenEWIS, will provide the end-user with clearer readability of complex electrical systems.

The key enabler to switch to real-time technical data is the “state of the art” structure of such data.

With a smooth transition plan from 2020 to 2022, Airbus will migrate A320, A330, A340 and A380 maintenance data from ATA iSpec2200 to the latest industry standard S1000D, used today for A350 XWB maintenance data.

This real-time technical data is a new philosophy for data consultation and exchange. Airbus will collaborate with operators, Maintenance, Repair and Overhaul (MRO) organisations, leasing companies and of course airworthiness authorities in the development of this new system.

Generate electrical wiring diagrams on demand

GenEWIS

(Generate Electrical Wiring Interconnection System)

Information on electrical components is delivered in sheets of drawings; systems are split based on ATA breakdown via the Aircraft Wiring Diagram (AWD). Depending on the system, several sheets sometimes need to be printed and assembled.

The amount of data produced by wiring products is growing exponentially and Airbus is transforming this information for the benefit of operators.

Starting with the A350 XWB and from the beginning of 2019, Airbus will provide a new dynamic view of electrical system routing with GenEWIS.

The Aircraft Wiring List (AWL) database will be used as a master to generate wiring diagrams on demand. The end-user will have an interactive display capable of showing all electrical systems, from very small subsets to much larger drawings.

Airbus’ intention is to improve the airlines’ efficiency during electrical trouble-shooting activities, improve the system configuration readability and improve Airbus’ capability to provide more frequent electrical updates, everything being based on the AWL database.

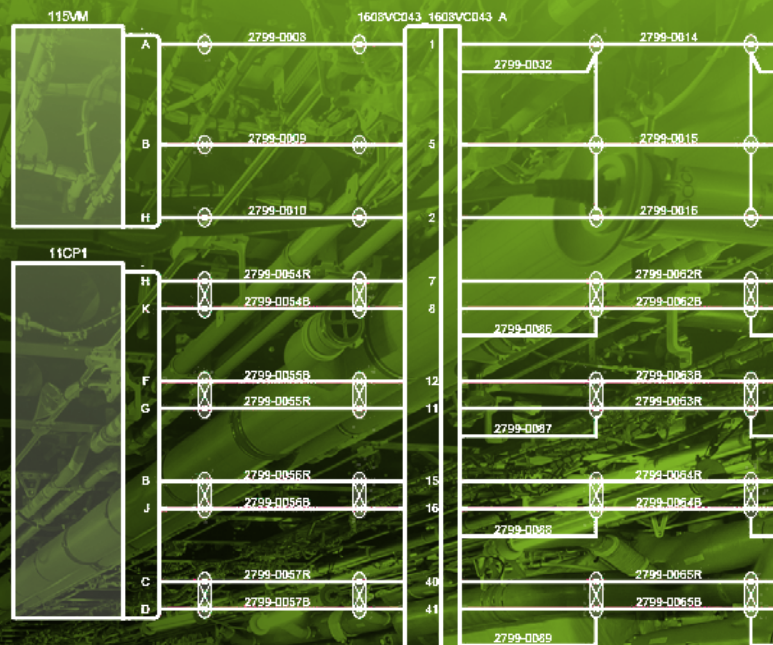

From manual consolidation to automatic data delivery

At Transfer of Title (TOT), operators receive from Airbus the Aircraft Inspection Report (AIR), providing a snapshot of all relevant part numbers, serial numbers and functional item numbers of the aircraft. Manual consolidation of this data is both time and resource consuming for operators.

To support operators during the entry-into-service, Airbus proposes a unique digital solution: Airbus Configuration of Tracked Units at Aircraft Level (ACTUAL). This product is delivered online per aircraft and provides the airline maintenance and engineering teams with a complete and organised view of all part numbers, serial numbers, and functional item numbers of their aircraft.

Using the latest spec2000 XML format, ACTUAL avoids the risk of manual error and offers a clear hierarchical structure of each operator's aircraft configuration: the parts are listed according to their function and position on the aircraft. ACTUAL gives airline maintenance teams the ability to automatically load aircraft configuration data directly into their Maintenance Information System.

The Illustrated Parts Catalogue provides end-users with part number information including part interchangeability which can be complex, depending on the aircraft system. From mid 2018, customers will be able to quickly retrieve the part number applicable to one aircraft at a specific location, thanks to a new tool called ALLOWABLE. The customer will then be able to extract all this information in eXtended Mark-up Language (XML) for direct integration in their Maintenance Information System allowing the end-user to refer directly to the airline system to get the part number information.

Aircraft maintenance technical data

Keep electrical load data up-to-date

ELA Update (Electrical Load Analysis)

Aircraft increasingly rely on electrically driven components and circuits on their most vital systems.

Airbus help operators manage the electrical load of their aircraft and supports them to meet regulatory requirements. With the ELA Update service, Airbus provides operators with a revised ELA based upon all reported electrical changes on their aircraft since delivery.

With ELA Update, Airbus will analyse the impact of an operator's reported Service Bulletins and/or Supplementary Type Certificates and provide them with an updated ELA.

Airbus has also developed a new training course on ELA Update, to provide airline engineering teams with all the skills and knowledge needed to update electrical load documentation by themselves.

Get enhanced overview of aircraft SB configuration

ACM+ (Aircraft Configuration Matrix)

An aircraft's configuration changes throughout its lifecycle, with upgrades and retrofits carried out via Airbus Service Bulletins or Vendor Service Bulletins.

To follow every modification and its impacts on maintenance manuals, customers can use the ACM+ service to have a comprehensive view of their aircraft SB configuration associated to a global traceability of SB status.

The aircraft transfer process between two entities always requires significant configuration checks: the ACM+ allows customers to save time during those crucial moments.

Since the beginning of 2017, the ACM+ enables customers to have all configuration and applicable Service Bulletins' status in one place.

This enhanced version of the ACM contains, when applicable, valuable complementary data such as the references of safety publications associated to SBs, e.g. Airworthiness Directives or Operations Engineering Bulletins. The ACM+ also indicates SBs originating from Vendor SBs and SBs requested by the customer. It provides the date of the SB reporting to Airbus and the reference when reported online.

CONCLUSION

Technical data is key for efficiently operating an airworthy aircraft.

Airbus continuously monitors technological developments and applies them to documentation and Information Systems' functionalities, production and methods of transmission.

Based on end-user feedback, Airbus is constantly enhancing content by improving the clarity and accuracy of maintenance and engineering data.

By investing in new solutions, Airbus is looking to minimise technical data management for operators.

The new browser, airnav^x, has been developed to ease consultation of this data, allowing operators to have one fast and reliable application to access the vast majority of maintenance and engineering data. Latest industrial standards are used to deliver and exchange the data with the aircraft operators.

Online access and consultation will continue to be the major axis of improvement for the years to come. Collaborative platforms are being put in place to share information and smart media.

Airbus is working on the future, with a real-time technical data concept that allows the end-user continuous access to the latest version of maintenance data. ■■■

A350 XWB vertical stabiliser continuous joint

Precision technology for attachment fittings

The A350 XWB now uses a more optimal way of connecting the stabiliser to the fuselage using a continuous joint. This in turn has led to a new and more precise way for customers to measure bolt tension.

Article by

Raquel HERNANDEZ-GONZALEZ
A350 XWB In-Service/Maturity Manager
Chief Engineering Office
AIRBUS
raquel.hernandez-gonzalez@airbus.com



This new A350 XWB design concept provides a more evenly distributed transfer of loads along the joint between the vertical stabiliser and fuselage.

The fuselage interface includes a set of tension and shear fittings that continuously connects the shells, stringers and spars of the vertical stabiliser centre-box to the skin and frames of the unpressurised rear fuselage structure.

The optimised load distribution in the joint reduces requirements for redundancies in each bolt compared to the classic multi-lug concept. This allows better stress control and reduces structural weight, improving fuel performance as a consequence. In addition, with no external fairing required thanks to the joint, there is less drag which again contributes to fuel efficiency.

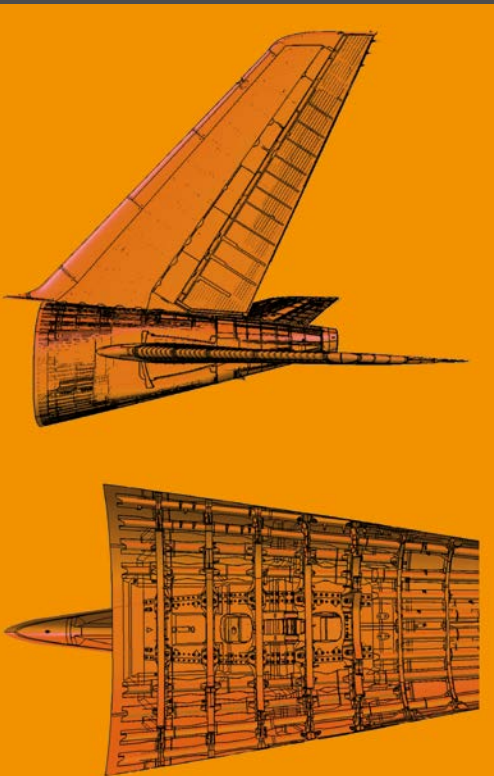

Traditional lug attachment

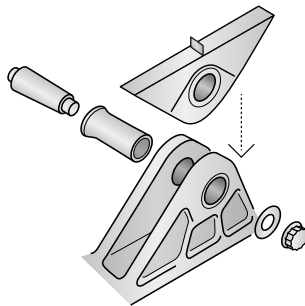

Tension bolt system

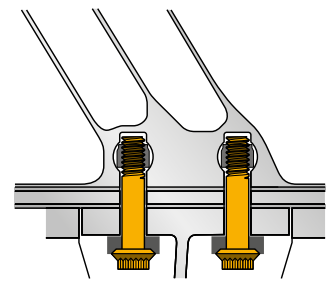

In previous aircraft families, the attachment principle of the vertical stabiliser consisted of a multi-lug joint assembled with tapered bolts and sleeves.

This A350 XWB design enabled the development of a new torque system using the latest ultrasonic technology for tension measurement.

The ability to measure more accurately led to reduced tolerance margins taken in the definition of the continuous joint and more precision when monitoring its situation once in-service.

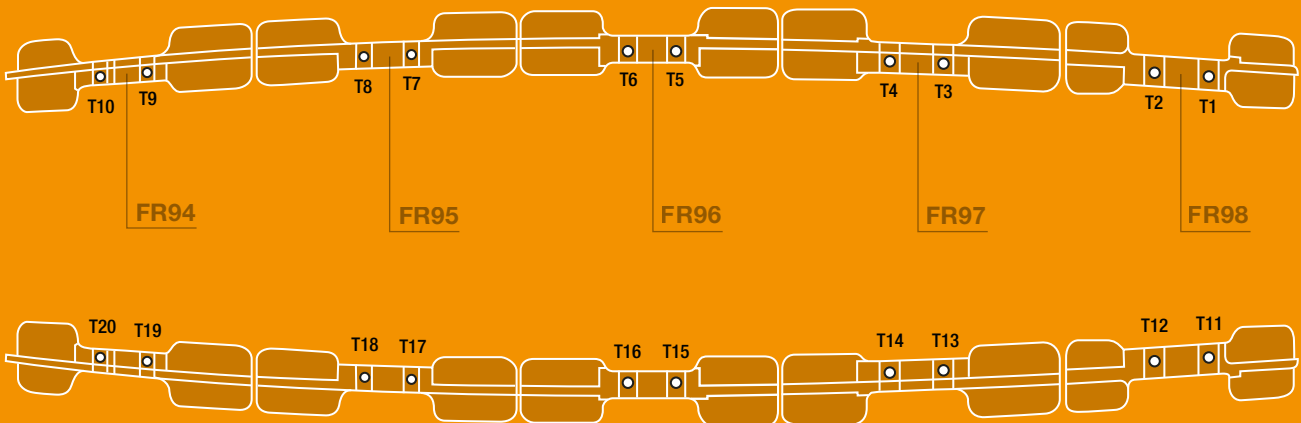

The A350 XWB vertical stabiliser is held in place with 20 tension bolts that optimise the load distribution over a continuous joint.

The tension bolts are standard parts, and are installed at the inner side of the vertical stabiliser skin. The diameter of the bolts in each frame is different depending on the load to be supported.

These bolts are pre-loaded with nominal tension values in accordance with design specifications. The tension value in the joint is defined by taking into consideration a relaxation of the preload values, to a certain extent, during the first days after installation. The preload of the tension bolts is monitored during operational life. This monitoring has been included as a mandatory task of Airworthiness Limitation Section Part 2 of the A350 XWB Maintenance Programme, and is performed every 3600 flight cycles or 3 years whichever comes sooner.

When conducting this maintenance task, preload values per location and temperature of the joint should be noted. Minimal nominal preload values for each frame location are different and are dependent on temperature because tension bolt material expansion influences ultrasonic measurement and the value has to be adapted to the material's thermal expansion coefficient. The principle of this behaviour is shown in the following graph. Depending on the preload value found when measuring, operators have to proceed accordingly.

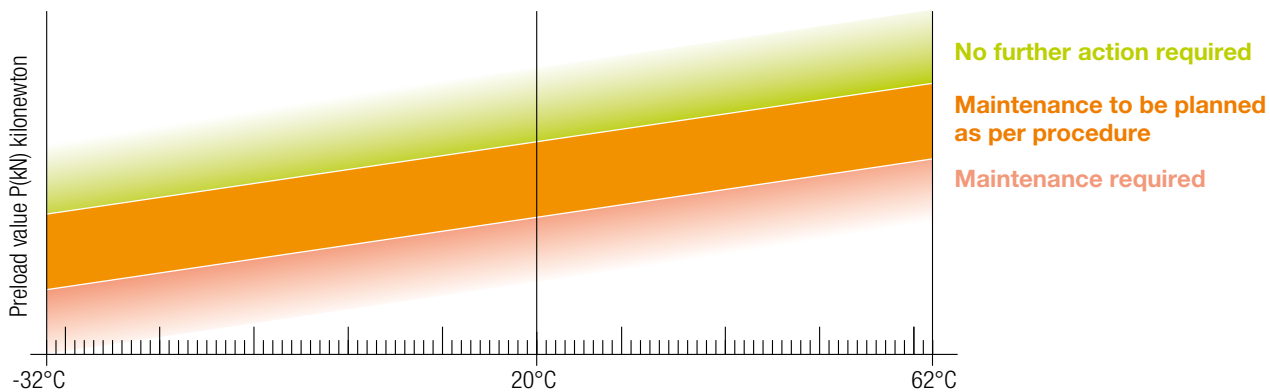

Bolt calibration data principle

Tension bolts for the A350 XWB vertical stabiliser and fuselage continuous joint have a sensor on their head that can be read by an ultrasonic measuring device. This ultrasonic device allows precise control when preloading the bolt during installation on the Final Assembly Line.

The precision of ultrasonic measurement enables the use of smaller diameters, thereby increasing structural strength, compared to tension bolts without sensors. If the measurement when applying the load is more precise, the required tolerance is lower. In the past, high tolerance levels have been given for pre-tension values due to the friction during load application.

This method also allows the use of a simple measurement tool during required maintenance checks that is key for guaranteeing the required bolt preload value for the continuous joint's in service performance.

Preload measurement principle

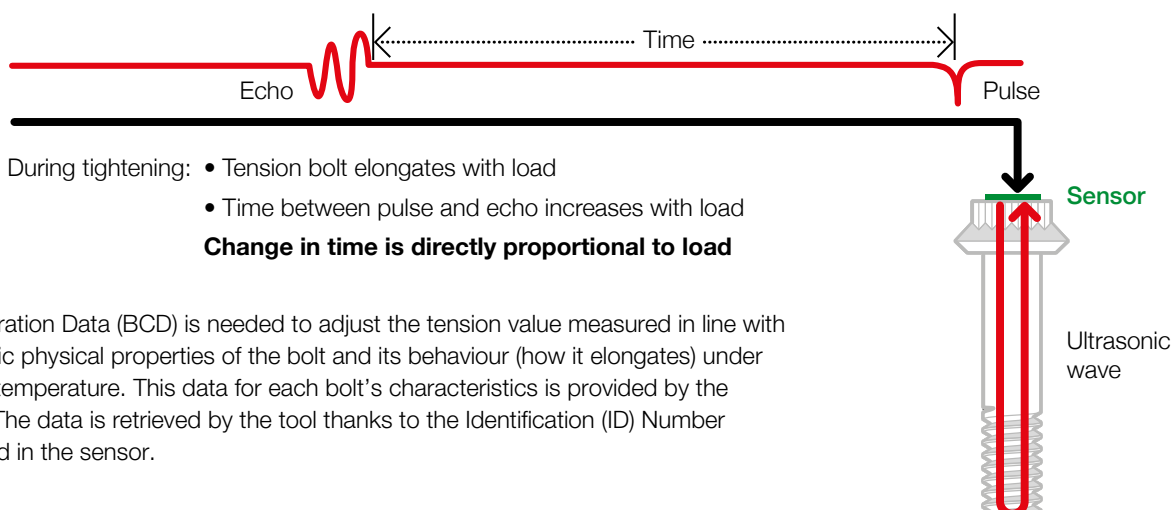

Bolt Calibration Data (BCD) is needed to adjust the tension value measured in line with the specific physical properties of the bolt and its behaviour (how it elongates) under load and temperature. This data for each bolt's characteristics is provided by the supplier. The data is retrieved by the tool thanks to the Identification (ID) Number embedded in the sensor.

These sensors are equipped with a 2-dimensional bar code which contains a 12-digit ID, so that every bolt is uniquely identified.

This ID is specific to each individually manufactured bolt and corresponds with that bolt's data on an automatic database, called Bolt Calibration Data (BCD), which contains all information relevant to the traceability of the bolt (lot number, bolt manufacturer, date of calibration, characteristics of the raw material, etc...).

This database is uploaded to the measurement tool which compares the time of an ultrasonic wave travelling in the material, to establish the tension value of the bolt.

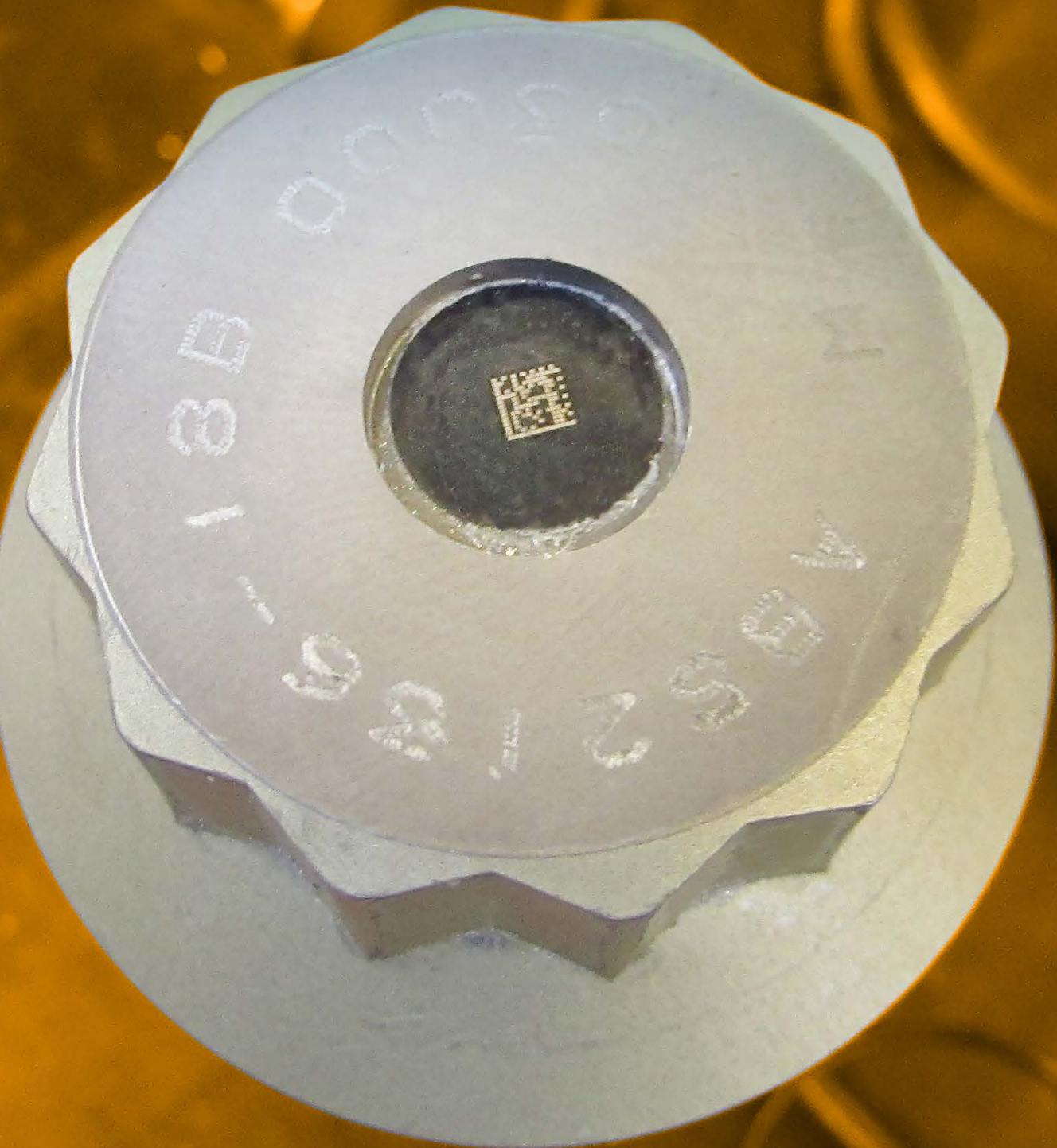

Vertical stabiliser installation overview and management of bolt calibration data in Airbus

The new continuous joint concept, along with the ultrasonic measurement of the tension bolts, required a new approach to the installation of the vertical stabiliser in the Final Assembly Line.

The A350 XWB's vertical stabiliser is installed with a specific sequence on the tightening of the tension bolts depending on their location. The tool used for tightening is uploaded with the Bolt Calibration Data. It then automatically reads the ID of the bolt and applies the correct load related to the specific location and the temperature measured.

The preload values, ID and location of each of the twenty tension bolts are recorded following a specific work order. The IDs are then provided to the customer in the Product Quality Report (PQR) that is delivered with aircraft documentation.

After installation, the preload value is measured again after 12 hours to check that the values are above the nominal ones after the expected preload relaxation.

The BCD is updated with newly manufactured bolts and the files comprising the BCD are cumulative files that contain all data of tension bolts manufactured by the supplier (see boxes to the right).

In order to ensure proper management of the BCD associated to the tension bolt's logistic management within the FAL, a dedicated team ensures that this data is uploaded to the applicable tools. The Airbus Customer Services team then publishes it in AirbusWorld, the customer portal.

Ensuring in-service support for customers

To enable airlines to perform this scheduled maintenance task, Airbus has defined the necessary support means for monitoring the preload value of tension bolts in the vertical stabiliser's continuous joint. This support is covered by Airn@v Maintenance, Ground Support Equipment (GSE) and other data such as the BCD.

How to measure the preload value

The maintenance procedure required of airlines is a Special Detail Inspection (SDI) on which the preload of the tension bolts is to be measured every 3600 flight cycles or 3 years, whichever occurs first. This SDI procedure is the reference MP A350-A-55-3X-XX-02001-301A-A in the Airn@v Maintenance. This procedure requires that the aircraft is in a hangar to maintain stabilised temperature across the structure assembly due to the preload's dependence on temperature.

Access to the area is through the door on S19, with installed platforms and a ladder to reach tension bolts on the S19 top frames.

The measurement tool which is prepared with a Pre-Load Indication (PLI) system is the LoadMaster 3600 (LM3600). This tool, once uploaded with the BCD, is able to start the process to read the preload value. The tool is then calibrated before carrying out the bolt measurement, following the appropriate indications provided in the GSE user guide.

When using the probe of the measurement system, the sensor should be very clean and the approach to the tension bolt sensor should be done in two steps: first bar-code scanning and second, load measurement. The difference between these steps is in the pressure applied to the probe on the sensor as shown in the figure to the right.

A350 vertical stabiliser tension bolt delivery procedure

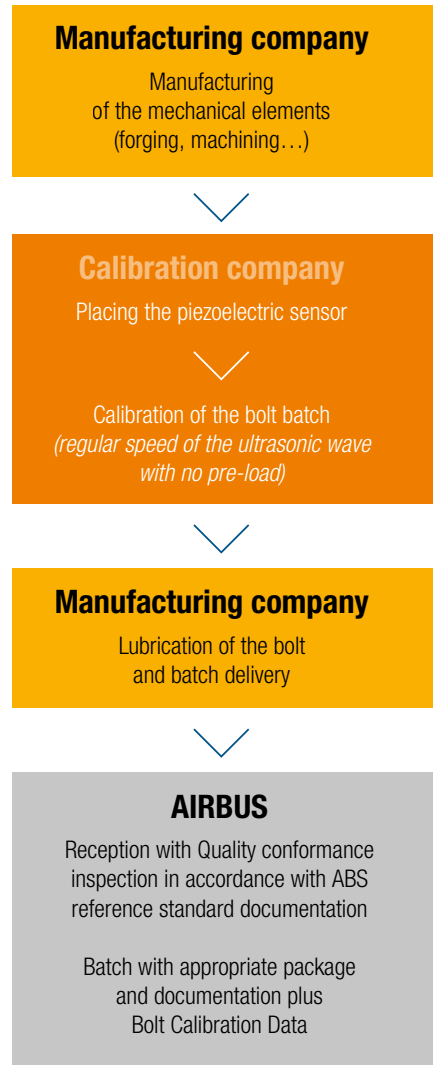

Difference in pressure probe for bar code scanning and load measurement

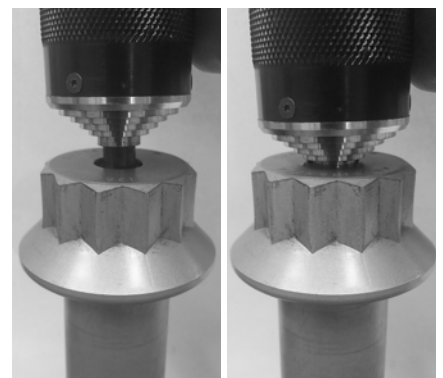

Frame temperature measurement tool



Bar code reader and ultrasonic load measurement tool



Measurement of location temperature

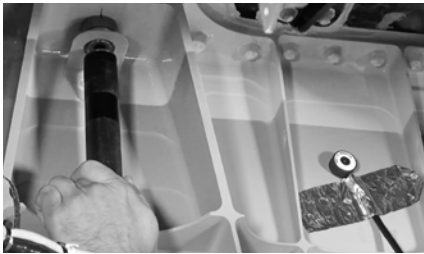

The LM3600 measurement tool has a temperature sensor that should be located in the frame of the tension bolts to be measured.

Once the measurements have been done, the preload values and ID of the tension bolts should be noted in the report included in the Maintenance Procedure (MP). The completed report should be sent back to Airbus (mpdtask.reports@airbus.com).

If measured values in-service are found to be outside of the recommended ones as per design, the re-torque of tension bolts needs performing to restore the nominal values. Depending on the specific value, this action should be undertaken in a different timeframe, following the indications provided in Airbus publications. Airlines can either purchase or lease the required GSE as per MP A350-A-55-3X-XX-02001-301A-A in Airn@v Maintenance.

The full MP A350-A-55-3X-XX-02001-301A-A can be done within two days with two mechanics. Customers can consult a dedicated video covering the topic on AirbusWorld.

Airbus also offers airlines specific working parties to conduct both measuring and tightening as required. Operators can request via: embodiment-operations@airbus.com.

The Airbus working party will provide tailored services including GSE provisioning.

Feedback for enhanced support

Airlines can benefit from enhanced support by reporting the MP A350-A-55-3X-XX-02001-301A-A inspection to Airbus, including the preload measurements and the basic values for conditions of measurement. This reporting allows Airbus to gather data from the field to enhance in-service support for airlines, as well as contributing to the Airbus global fleet-monitoring database.

This information, coupled with data already generated by Airbus, will enable an informed analysis of whether the relaxation of the preload value over time correlates with test data. If sufficient data is gathered and with positive results, the objective is to increase the inspection interval for preload value checks of A350 XWB in-service aircraft.

CONCLUSION

The new design concept for the A350 XWB vertical stabiliser enables a more even load distribution and contributes to fuel efficiency thanks to improved stress management, reduced drag and weight loss.

Tension bolts are now used to connect the stabiliser to the fuselage and ultrasonic technology enables precise measuring of the bolt preload value. Operators can carry out the measuring and any necessary adjusting themselves or request support from Airbus. Further details can be found in Airn@v Maintenance on the Airbus World customer portal.

Supporting ageing fleets

Scheduling the unscheduled

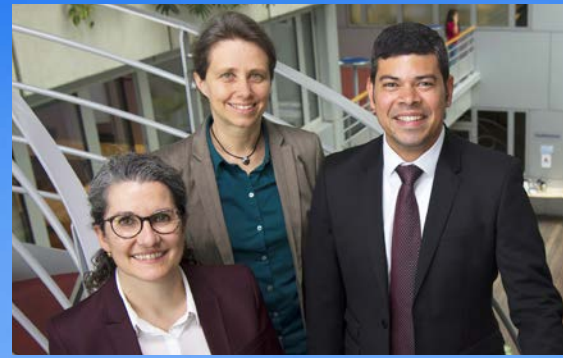

Article by (left to right)

Isabelle REMAURY-LANDO
A330/340 Family Programme Support Manager
AIRBUS
isabelle.remaury-lando@airbus.com

Delphine MEUNIER
A300/310 Family Programme Support Manager
AIRBUS
delphine.meunier@airbus.com

Hugo Alberto QUIJANO FIALLOS
A320 Family Programme Support Manager
AIRBUS
hugo-alberto.quijano-fiallos@airbus.com

There are currently around 10,000 Airbus aircraft in-service, with the whole fleet growing at an increasingly faster rate. And the ageing Airbus fleet is set to more than triple over the next 10 years.

These aircraft require particular attention. Airbus has carried out in-depth studies to address ageing issues in terms of risk evaluation, anticipation and appropriate mitigations.

Airbus fleet age profiles

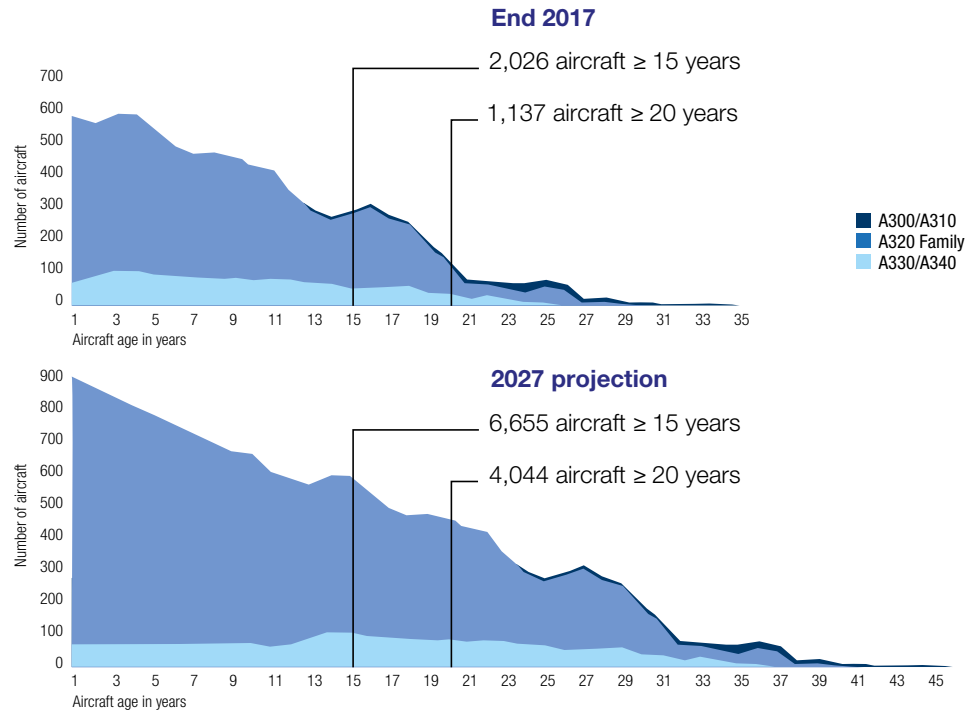

Airbus considers that an ageing aircraft is one that has been in service for around 15 years and/or has reached half of its Design Service Goal (DSG) limit.

Operators looking to keep their aircraft in service as long as possible can benefit from different support:

Extending the aircraft life

The aircraft life can be extended beyond its original recommended limit, in line with Airbus recommendations or ESG (Extended Service Goal)

Once an aircraft is in service, it accumulates Flight Cycles (FC) and Flight Hours (FH) up to the “Design Service Goal”, meaning the point up to which the maintenance programme has been validated. However, aircraft can actually be operated beyond this point if the ESG – Extended Service Goal – has been applied.

DSG
Design
Service
Goal

Refer to page 37 for more about the definition of service goals.

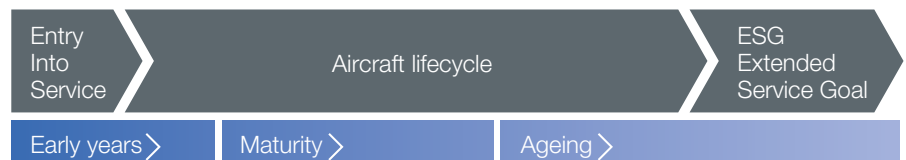

Anticipating for areas affected by ageing

Being able to foresee ageing issues and thereby plan maintenance in advance is key and Airbus has been working alongside airlines to anticipate their needs. The areas affected by ageing are the **aircraft structure**, which result in fatigue and corrosion, and **systems performance**.

Structure: facing fatigue

The accumulation of Flight Cycles (FC) and Flight Hours (FH) can cause cracks in fatigue-sensitive areas. Specific inspections have therefore been introduced in the maintenance programme. In addition, the risk assessment helps anticipate potential aircraft ground-time overrun, and provides visibility to assist management decision-making.

To anticipate specific maintenance on ageing aircraft, Airbus made a complete review of all mandated fatigue-related inspections which were part of the Airworthiness Limitation Section (ALS) Part 2, published inspections resulting from fatigue; this review was based on fatigue test results and customer in-service feedback.

It focused on Airworthiness Limitation Items (ALI) identified with high finding rates and complex repairs requiring a significant time to embody. The result was the development of pre-defined repair solutions, spares, tools and hardware provisioning in anticipation of customers' needs.

To identify fatigue-crack critical areas, Airbus established a specific process that provides continuous assessment of the fleet:

Step 1 Risk versus in-service effect

Airbus calculates the probability of findings at fleet level and assesses repair complexity in case of findings

Step 2 Optimisation of inspections and definition of solutions

Based on the critical findings from step 1, an analysis is launched to see if there are opportunities for:

- Optimisation of inspection thresholds and intervals
- Forward fit and retrofit modifications
- Additional repair solutions taking into account already available repair solutions

Once identified, those areas still judged as highly critical are retained and taken to step 3

Step 3 Implementation of solution

For each of the previous identified areas of improvements/opportunities, the final step is to secure:

- Inspection documentation update with appropriate threshold and interval
- Modification development and certification
- Development of new repair solutions in various formats such as Structural Repair Manual (SRM) update, Pre-Defined repair Solutions (PDS), single part replacement

Finally for these actions, associated material availability is reviewed accordingly. The detailed content of the kits depends on the type of finding, the initial configuration of the aircraft and any repairs already performed in the area. Consequently, to avoid work stoppage during maintenance checks, Airbus has speculated on the most probable configurations of kits and stocked them in SATAIR warehouses.

Structure: coping with corrosion

Similarly to the above fatigue-related methodology, Airbus reviewed more than 40,000 inspection reports coming mainly from Maintenance Planning Document (MPD) inspections and reports relating to corrosion findings.

As an illustration of the analysis, Airbus were able to confirm for A330/A340 Family and A320 Family that 80% of the reported findings come from only 20% of the total number of existing inspection tasks.

Airbus is currently focusing on:

- Effectiveness of modification (monitoring)
- Spares availability
- Repair/Allowable Damage Limit (ADL) improvements
- Continued monitoring of the in-service fleet findings in the coming years to adapt recommendations and maintenance tips

To ensure that this fleet monitoring is based on representative in-service data, Airbus encourages operators to report inspection results to them, such as no findings, or findings within and above the ADL.

Systems: recommendations and solutions

Aircraft systems are reviewed in order to establish appropriate actions that limit the effects of ageing.

As agreed with airlines, the main system operational drivers to focus on were:

ATA 21/36 - Air systems

ATA 27- Flight Controls

ATA 28 – Fuel systems

ATA 29 – Hydraulic systems

ATA 32 – Landing Gear systems

For the A300/A310 Family, as requested by operators during the 2015 symposium in Berlin, best practices and preventive maintenance actions have been compiled (refer to A300/A310 ISI 00.00.00194 in AirbusWorld).

Best practices and preventive maintenance actions have also been compiled for the A320 Family and presented to the operators during the 2017 symposium in Berlin (refer to A320 ISI 00.00.00248 in AirbusWorld).

Similarly, for the A330/A340 Family, a FAIR Face-to-Face working group with airlines was launched in 2016. Following a review of recommendations already published in WISE articles/ ISIs and after further discussions with airlines, very few additional areas of investigation were identified.

The outcome of this A330/A340 working group confirmed for all identified topics that either:

- The topic is already known and the solution is available
- The topic is already known and Airbus is currently working on defining a solution or maintenance recommendation. Discussions continue between airlines and Airbus to follow up activities related to these topics
- The topic is a non-issue and airlines agreed no engineering activities should be pursued.

Finally, it was also demonstrated that there is no apparent ageing effect on components which are often removed from aircraft and maintained through shop activities (overhaul).

Example:

The main area of concern is around items remaining on the aircraft (e.g. hydraulic/fuel line...), for which a number of maintenance tips and recommendations are already available through Airbus WISE Knowledge Management system (ISI articles as shown in below illustration – A330/A340 ISI 29.00.00160 – A320 ISI 29.00.00012).

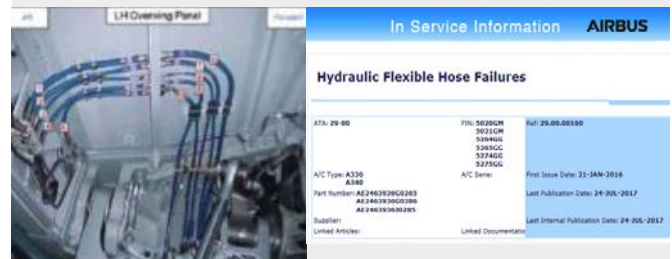

GLOSSARY

- ADL** Allowable Damage Limit
- ALI** Airworthiness Limitation Item
- ALS** Airworthiness Limitation Section
- DSG** Design Service Goal
- ESG** Extended Service Goal
- FC** Flight Cycles
- FH** Flight Hours
- ISG** Intermediate Service Goal
- ISI** In-Service Information
- ISB** Inspection Service Bulletin
- MPPT** Maintenance Programme Publication Trigger
- MRBR** Maintenance Review Board Report
- WISE** World In-Service Experience



A300/A310 Family symposium (2015, Berlin)
Solutions for Ageing Aircraft



A330/A340 Family Americas Regional conference (2016, Miami)
Supporting ageing fleet, Extended Service Goal and Widespread Fatigue Damage

A320 Family ageing support

- >AirbusWorld
- >Content Library
- >Maintenance & Engineering

Defining service limits

When previous Airbus programmes were launched, aircraft were certified with an objective to reach a specific Design Service Goal (DSG), defined in terms of Flight Cycles or Flight Hours (refer to table below).

In order to support Airbus aircraft which were actually reaching their DSG limit faster than anticipated, Airbus launched appropriate engineering studies to certify an increase in FH for some aircraft types: this was called the Intermediate Service Goal (ISG). Studies continued for the Extended Service Goal (ESG) for additional life extension. The table below gives the values for DSG, ISG and ESG.

Airbus Extended Service Goal packages can enable operators to increase the operational lifetime in terms of flight hours and flight cycles. This can bring up to 10 years or more of additional revenue service above the initial design objectives.

Another limitation was also introduced by the FAA in the frame of the FAR26 new regulation on widespread fatigue damage topic: Limit of Validity (LoV) which is not to be mistaken with the DSG/ISG/ESG definition as it has no relation to this limit.

These definitions have been completed by a new term which is being used in the Airworthiness Limitation Section documents: **the Maintenance Programme Publication Trigger (MPPT)** which is the equivalent to former DSG/ISG/ESG depending on the aircraft configuration.

	DSG		ISG		ESG	
	FC	FH	FC	FH	FC	FH
A300 B2	48,000	52,000	NA	NA	48,000	75,000
A300 B4-100	40,000	53,000	NA	NA	48,000	75,000
A300 B4-200 / C4 / F4	34,000	70,000	NA	NA	48,000	75,000
A300-600	30,000	67,500	NA	NA	51,000	89,000
A310	35,000	60,000	NA	NA	40,000	116,000
A318	48,000	60,000	NA	NA	NA	NA
A319	48,000	60,000			60,000	120,000
A320	48,000	60,000	37,500	80,000	60,000	120,000
A321	48,000	60,000			60,000	120,000
A330-200 (WV 000 and WV 020 series)	40,000	60,000	33,000	100,000	40,000*	130,000
A330-300 (WV 000 and WV 020 series)	40,000	60,000	33,000	100,000	40,000*	126,000
A330 (WV 50 series)	33,000	100,000	NA	NA	TBD	TBD
A330neo	33,000	100,000	NA	NA	TBD	TBD
A340-200	20,000	80,000	20,000	100,000	25,000	134,000
A340-300 (WV 000 and 020 series)	20,000	80,000	20,000	100,000	31,000	156,000
A340-300 (WV 50 series)	20,000	100,000	NA	NA	TBD	TBD
A340-500/600	16,600	100,000	TBC	TBC	TBC	TBC

■ Pending certification planned Q1 2018

*A330 (WV000 & 020) FC limit for aircraft structure is 44,000 FC

■ TBD: Engineering activities starting mid-2018 for A330 WV050 (ESG objectives similar to A330 basic)

■ TBC: To be confirmed if required depending on A340-500/600 future operations

E.g. Describing a customer's A340-200

- *Previous terminology:* The aircraft had a DSG of 20,000 FC and 80,000 FH. This could then be extended to an ISG of 20,000 FC and 100,000 FH by implementing Service Bulletin (SB) A340-00-4065, then to an ESG of 25,000 FC and 134,000 FH by implementing SB A340-00-4001 if the operator wanted.

- *New terminology:* The aircraft has an MPPT value. This is equivalent to the former DSG, ISG or ESG values and depends on aircraft configuration (pre or post the above SBs).

CONCLUSION

As an aircraft ages, it is likely to require attention to its structure and systems. Anticipating potential findings, repair solutions and parts availability can significantly contribute to optimising maintenance planning and to ensuring aircraft availability.

Airbus engineering teams have identified the main structural areas to focus on. Modifications and repair solutions are already available or in development. On the systems side, in cooperation with airlines, Airbus has developed maintenance best practices and recommendations to better manage ageing fleets.

Recommendations and solutions have been communicated to Airbus customers via regular meetings or are available in the AirbusWorld portal. Airbus continues to monitor and strongly support ageing aircraft in order to respond to customers' needs and expectations. ■

FAST from the past

There wouldn't be any future
without the experience of the past.



Not so very long ago in 1985, the first Carbon Fibre Reinforced Plastic vertical tail spar box for the A310-A300 started series production at the Messerschmitt Bölkow-Blohm stabiliser plant in Germany.

The component is nine metres high, 3.1 metres wide at the bottom and 1.4 metres wide at the top. At the time, it was the largest primary structure ever developed and manufactured for a civil aircraft.

Around the clock, around the world



Airbus has more than 300 field representatives, based in over 130 cities

USA/CANADA

Tel: +1 703 834 3484
Fax: +1 703 834 3464

CHINA

Tel: +86 10 8048 6161 Ext. 5020
Fax: +86 10 8048 6162

FIELD SERVICE SUPPORT ADMINISTRATION

Tel: +33 (0)5 6193 3936
Fax: +33 (0)5 6193 4964

Technical, Material & Logistics

Airbus Technical AOG Centre (AIRTAC)

Tel: +33 (0)5 6193 3400
Fax: +33 (0)5 6193 3500
airtac@airbus.com

AOG Spares Centre of Competence

For Europe, Africa, Middle East,
Asia-Pacific & China:
Tel: +49 (0)40 5076 4001
Fax: +49 (0)40 5076 4011
aog.spares@airbus.com

For Americas:

Tel: +1 70 3729 9000
Fax: +1 70 3729 4373
aog.na@airbus.com

Spares RTN/USR, WSP and HMV Orders

For Europe, Africa, Middle East,
Asia-Pacific & China: Please contact your
dedicated Single Point of Contact (SPOC).
More info:

Tel: +49 (0)40 5076 4002
Fax: +49 (0)40 5076 4012
ifd.spares@airbus.com

For Americas:

Please contact your dedicated
Single Point of Contact (SPOC).
More info:
cod.americas@airbus.com

Training centres

Airbus Training Centre

Toulouse, France
Tel: +33 (0)5 62 11 82 24
or +33 (0)5 61 93 39 75
Fax: +33 (0)5 6193 2094
training.commercial@airbus.com
customercare.atc-europe@airbus.com

Airbus Maintenance Training Centre

Hamburg, Germany
Tel: +49 (0)40 7438 8288
Fax: +49 (0)40 7438 8598
training.commercial@airbus.com
atc.hamburg@airbus.com

Airbus Material Management Training

Global Availability
Tel: +49 (0)40 5076 1228
spares.training@airbus.com

Airbus Training Centre Americas

Miami, Florida - U.S.A.
Tel: +1 (305) 871-3655 (switchboard)
Fax: +1 305 871 4649
miamicustomertrainingsales@airbus.com

Airbus Training Centre Beijing

Tel: +86 10 80 48 63 40 - 3017/3016
+ 86 10 80 48 65

Airbus Training Centre Bangalore

Tel: 91-080-6638230 (reception)

Airbus Training Centre Delhi

Tel: +91 9880065511

Training by Airbus Dubai,

UAE - Airbus Middle East FZE Dubai
Tel: +971 4 602 78 62
mary-knoll.garcia@airbus.com

Training by Airbus Jakarta

antoine.renaud@airbus.com

Airbus Asia Training Centre Singapore

Tel: +65 6877 4300 (reception)
contact.info.aatc@airbus.com

Airbus Mexico Training Centre

Tel: +52 55 57 86 80 50
(communication and marketing)
training.commercial@airbus.com

Training by Airbus Korea,

Seoul, South Korea
Tel: +82 (0)32 882 5425
andrew.rapson@airbuskorea.com

THE A321LR. MORE TIME ZONES LESS FUEL.



FLY
WE MAKE IT

At 4000nm the A321LR has the biggest range of any new single aisle aircraft in the world. Not only is it capable of opening the door to the long-haul market, it can do so with an incredible 30% reduction in operating costs. But it's not just designed to impress CFOs with unbeatable fuel efficiency. It is available with our state-of-the-art Airspace cabins to give passengers unparalleled comfort too.

Long-haul. We make it fly.