

J U L Y 2 0 0 5

F L I G H T

A I R W O R T H I N E S S

S U P P O R T

T E C H N O L O G Y

# FAST<sup>36</sup>

A I R B U S T E C H N I C A L M A G A Z I N E

J U L Y 2 0 0 5



**AIRBUS**





# FAST

FLIGHT  
AIRWORTHINESS  
SUPPORT  
TECHNOLOGY

M A G A Z I N E  
A I R B U S  
T E C H N I C A L

## Customer Services events

### Just happened

#### PERFORMANCE AND OPERATIONS CONFERENCE IN BANGKOK, THAILAND, 4 - 8 APRIL

Our vision for the EFB (Electronic Flight Bag) and its support, how to deal with Required Navigation Performance and the way to fly RNAV approaches were announced and discussed at this symposium. Other topics included: our legacy document project, the first A380 Flight Crew Operating Manual delivery, the A350 status, our vision on CNS/ATM (Communication Navigation Surveillance/Air Traffic Management), our concept and new tools for operational cost management and our vision of safety related equipment that will be fitted on our future aircraft. 300 flight operations specialists from 86 airlines and about 50 representatives from 19 vendors, associations and authorities participated in this very well appreciated event.

#### TECHNICAL DATA SUPPORT & SERVICES SYMPOSIUM IN ATHENS, GREECE, 25-29 APRIL

The modular concept of our advanced consultation tool 'AirN@v' was announced at this symposium. The concept will give seamless one-stop-access to aircraft documentation and significant gains in efficiency. It will also support our move to delivering 'Service-Oriented Data' in the coming years. There will be no rupture in the use of standards and delivery of data, as this will be totally transparent to technical data end-users. It was also announced that in line with Airbus' policy of applying new technology applications for existing aircraft programmes, Airbus has launched AirN@v for all A310 and A300-600 fleet customers. The symposium was much appreciated and customers fully endorsed Airbus migration from outdated media to full digital data application.

#### A320 FAMILY SYMPOSIUM IN RHODES, GREECE, 23 - 27 MAY

This had a record participation of 345: 167 from 91 airlines, 47 from 16 vendors and representatives of the Maintenance Repair and Overhaul Network. Evaluation forms gave a very high satisfaction level and, overall, we saw customers satisfied with A320 Family performance. The symposium gave an opportunity to exchange views and allowed Airbus to optimize its focus on operators' main issues. Customers acknowledged our improvements of their main concerns with projects such as Forum for Airlines Issues Resolution (FAIR), New Service Bulletin Concept, maintenance costs, Time To Get a Fix and also appreciated demonstrations of the latest A320 Family enhancements and the ongoing product evolution.

### Coming soon

#### A300/A310 FAMILY TECHNICAL SYMPOSIUM IN LISBON, PORTUGAL, 14 - 18 NOVEMBER

Preparation for this technical symposium is already in progress. There will be presentations on actual in-service issues affecting the A300/A310 Family programme as well as subjects of more general interest. For information, contact your local resident customer support manager. Agenda and participation forms will be sent out in September.

#### HUMAN FACTORS SYMPOSIUM IN MADRID, SPAIN, 22 - 24 NOVEMBER

Airbus will continue the dialogue with its operators at this symposium, discussing human factors aspects with practical and operational perspectives on:

- Flight operations (environmental, safety, pure ops e.g. procedures, philosophy, systems)
- Maintenance (safety, CRM, organization, procedures, manuals)
- Cabin operations (safety, CRM, organization, procedures, mass travel, medical aspects)
- Training (to flight operations, maintenance, cabin operations, to human factors)
- ATC (environmental, safety, pure operations e.g. procedures, philosophy, systems)



Cover: Low fuel temperature country

**Publisher:** Bruno Piquet  
**Editor:** Kenneth Johnson  
**Graphic Designer:** Agnès Massol-Lacombe

**Customer Services Communications**  
Tel: +33 (0)5 61 93 43 88  
Fax: +33 (0)5 61 93 47 73  
E-mail: fast.magazine@airbus.com  
Printer Escourbiac

FAST may be read on Internet  
[http://www.content.airbusworld.com/SITES/Customer\\_services/index.html](http://www.content.airbusworld.com/SITES/Customer_services/index.html)  
under Customer Services/Publications

ISSN 1293-5476

**Airbus Customer Services**

© AIRBUS S.A.S. 2005. All rights reserved

No other intellectual property rights are granted by the delivery of this Magazine than the right to read it, for the sole purpose of information. This Magazine and its content shall not be modified and its images shall not be reproduced without prior written consent of Airbus. This Magazine and the material it contains shall not, in whole or in part, be sold, rented, distributed or licensed to any third party. The information contained in this Magazine may vary over time because of future factors that may affect the accuracy of information herein. Airbus assumes no obligation to update any information contained in this Magazine. When additional information is required, Airbus S.A.S. can be contacted to provide further details. Airbus, its logo and product names are registered trademarks. Airbus S.A.S. shall assume no liability for any damage in connection with the use of this Magazine and of the materials it contains, even if Airbus S.A.S. has been advised of the likelihood of such damages

Photographs by Airbus France: Jean Jodar (page 5)  
exm company: Hervé Béranger, Hervé Goussé and Philippe Masclet

AFFC - Auto Fuel Feed Controller  
Upgrading your Airbus fleet for additional maintainability  
**Daniel Percy** 2

Low fuel temperatures  
Basics, principles of operations and a new software tool for predictions  
**Lars Kornstaedt** 5

AACT - Airbus Active learning and Competence focused Training  
A new approach to maintenance training  
**Christèle Bertrand** 12

T2CAS - Terrain and Traffic Collision Avoidance System  
Upgrading your aircraft by combining TCAS and TAWS in one unit  
**Christine Vigier** 16

A new concept for Service Bulletins  
Addressing airline expectations for Service Bulletins  
**Annick Pedron** 21

RFID - Radio Frequency Identification  
Supporting the aircraft supply chain  
**Andreas Teufel** 28

Customer Services  
Around the clock... Around the world 35

A double-decker of fifty years ago..... 36



This issue of FAST has been printed on paper produced without using chlorine, to reduce waste and help conserve natural resources. **Every little helps!**





Photo courtesy of Air Hongkong

# AFFC Auto Fuel Feed Controller

Upgrading your Airbus fleet for additional maintainability

On Airbus A310 and A300-600 aircraft types, supply of fuel to the engines is maintained by an automatic system, which controls the center and inner tank fuel pumps and the water scavenge pumps. The current system was conceived before widespread introduction of digital technology and consists of up to 30 fault and control relays, which are located in different avionics panels. The system architecture and implementation necessitates a good level of system knowledge to troubleshoot. Also, as the relays age with the aircraft, their reliability can decrease. These factors can increase the need and the time required for troubleshooting the system.

Recognising these factors, Airbus and Goodrich Fuel and Utility Systems joined forces to review the system and recently introduced an updated auto-feed system, which takes advantage of developments in digital computer technology.

The new Auto Fuel Feed Controller (AFFC) has been designed to dramatically improve maintainability and to augment the already high system reliability. In addition, the opportunity has been taken to introduce system operation improvements through the software control logic.



**Daniel Percy**  
Airbus Customer Services  
Fuel Systems Engineer  
Customer Services Engineering

## The Auto Fuel Feed Controller

Replacing all the relays of the current system, except for six essential for supply of power to the pumps, the AFFC is a line replaceable digital computer. It controls the inner and center fuel tank boost pumps, and the water scavenge pumps. As with the current system, the outer tank pumps are controlled independently of the AFFC.

In order to provide automatic control, the AFFC takes inputs from the aircraft power circuits, flight deck push button switches and the refuel panel. System inputs also come from the inner and center tank level sensors, the fuel quantity computer and pump feedback signals.

The AFFC has been designed to interface with the existing aircraft signals, and does not require any changes to the flight crew interface for its operation. When crew select auto-mode on the overhead fuel panel, the AFFC will operate to automatically control the fuel feed.

## Improved system maintainability through added functionality

The AFFC brings added functionality to the fuel feed system in order to greatly reduce troubleshooting workload. It achieves this by both reducing the number of autofeed faults seen on the aircraft and by providing efficient troubleshooting tools.

The amount of logic the current autofeed system can apply to the monitored system inputs is limited by the number of relays. Experience with the current system has shown that a number of indicated autofeed faults could be prevented by having additional logic within the system to take account

of transient aircraft conditions. Airbus and Goodrich Fuel and Utility Systems have therefore incorporated additional and improved logic within the AFFCs software. The result is a reduction in the number of indicated autofeed failures, and a subsequent decrease in maintenance workload.

When genuine autofeed system failures are indicated, the AFFCs BITE (Built In Test Equipment) function provides vastly improved assistance to maintenance crews to troubleshoot the fault. The AFFCs BITE has two levels of status indication, one for line maintenance and one for base maintenance personnel.

At line maintenance level, LEDs (Light Emitting Diodes) on the front panel of the AFFC provide fault codes, which indicate the status of the autofeed system, both internally and externally to the AFFC. The codes can be easily read from the AFFC and cross-checked with troubleshooting documentation to identify which components should be targeted by maintenance crews. This allows for rapid troubleshooting and helps dispatch of the aircraft. At the base maintenance level, an ARINC429 transmitter can be interrogated in order to provide system data for the past 20 flights. This transmitter can also be interrogated to obtain the current status of all discrete AFFC inputs and outputs.

Both the BITE and the ARINC429 transmitter are autofeed system improvements, enabling troubleshooting that is not feasible with the current system.

## AFFC installation

It is possible to install the AFFC on all A300-600 and A310 aircraft types, which do not already have it selected as an option. The installation is completed in two stages: Provisioning and installation. Both of these stages are covered

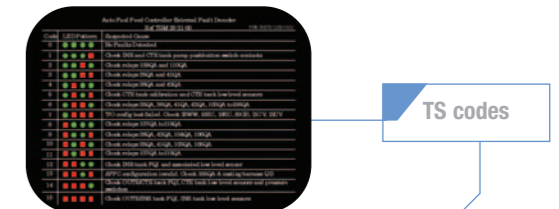
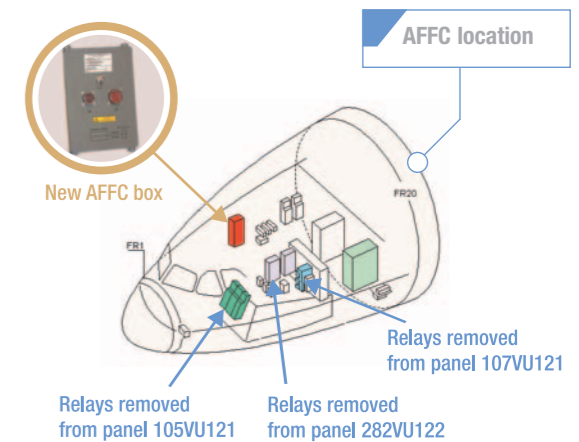

Code	LED pattern	suspected cause
0	●●●●	No faults detected
1	●●●■	Check INR and CTR tank pump pushbutton switch contacts
2	●●■●	Check relays 109QA and 110QA
3	●●■■	Check relays 35QA and 41QA
4	●■●●	Check relays 36QA and 42QA
5	●■■■	Check CTR tank calibration and CTR tank low level sensors
6	●■■■	Check relays 35QA, 36QA, 41QA, 42QA, 103QA to 106QA
7	●■■■	T/O config test failed. Check 25WW, 18KC, 19KC, 50GB, 21CV, 22CV
8	■●●●	Check relays 107QA to 110QA
9	■●■■	Check relays 36QA, 42QA, 104QA, 106QA
10	■●■■	Check relays 35QA, 41QA, 103QA, 105QA
11	■■■■	Check relays 107QA to 110QA
12	■■■■	Check INR tank FQI and associated low level sensor
13	■■■■	AFFC configuration invalid. Check 185QA-A mating harness (J1)
14	■■■■	Check OTR/CTR tank FQI, CTR tank low level sensors and pressure switches
15	■■■■	Check OTR/INR tank FQI, INR tank low level sensors

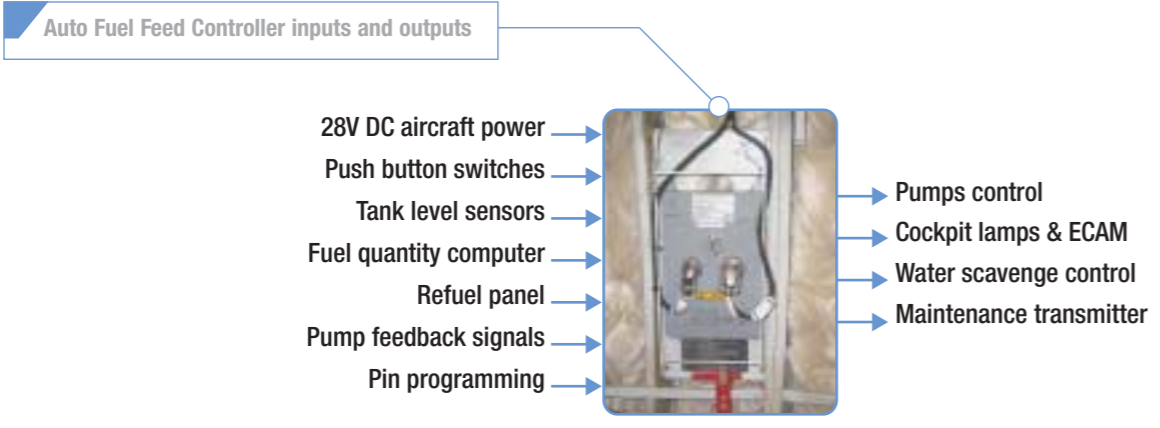

by Service Bulletins (SBs), which are already available from Airbus.

During the provisioning a new wiring harness is installed in the forward avionics bay between the AFFC and the relays, which are to be replaced. A mounting cage is also installed in the avionics bay between frames 12 and 12A. These modifications have already been completed prior to delivery on aircraft from MSN 859 onwards.

The installation stage reconfigures the aircraft wiring to connect the provisioned harness to the fuel system electronics and then remove the current relays. Once this is completed, the AFFC is installed in the mounting cage, and the harness plugged in to the AFFCs connectors to complete the new system. Finally, some cleanup work is completed in order to remove cables made redundant by installation of the AFFC.

**CONTACT DETAILS**  
**Daniel Percy**  
 Airbus Customer Services  
 Fuel Systems Engineer  
 Customer Services Engineering  
 Tel: +33 (0)5 62 11 76 33  
 Fax: +33 (0)5 61 93 32 73  
 daniel.percy@airbus.com

## Conclusion

Troubleshooting of faults on relay based automated aircraft systems requires a good level of system knowledge and generally needs longer time periods when compared to the functionality provided by the BITE of digital systems. For A300-600 and A310 aircraft autofeed system relays that are ageing and may be experiencing an increase in unscheduled maintenance, the AFFC offers the opportunity to enhance fleet reliability and limit the risk of dispatch delays.

The AFFC has been in operation with two operators since early 2005 and has accumulated over 3200 flight hours so far without any faults reported on the autofeed system. The system is available and the standard SBs can be ordered by any operator wishing to embody the modification.



# Low fuel temperatures

## Basics, principles of operations and a new software tool for operational predictions

With the operation of the very long range A340-500 and -600 on polar routings, the exposure of Airbus aircraft to low fuel temperature issues has increased. This article summarizes some basics regarding the minimum fuel temperature that can be tolerated, reviews the principles of the FUEL LO TEMP procedures

on the Electronic Centralized Aircraft Monitor (ECAM) and in Flight Crew Operating Manual (FCOM) 3.02.28 and describes new software now available to operators to predict fuel temperatures for a given flight at the time of dispatch.



**Lars Kornstaedt**  
 Airbus Customer Services  
 Group Manager A380 Performance  
 Flight Operations Support and Services



## Minimum allowed fuel temperature

Operating the aircraft within the certified environmental envelope is not sufficient to prevent issues with cold fuel. Indeed, safe engine operation leads to two engine-specific limitations: the minimum inlet temperature and the fuel heat management system limitation.

More information on fuel characteristics is given in the 'Getting to Grips with Cold Weather Operations' brochure available from Airbus.

### FUEL FREEZING POINT

The fuel characteristic that best describes the lower limit in temperature for use in aircraft operations is not actually the fuel freezing point, but the pumpability limit. This limit is very close to the pour point, a temperature at which the fuel, cooled without stirring, will only just still pour from a standard glass cylinder. However, since the pour point is difficult to determine accurately, the fuel freezing point continues to be used as a reference for low-temperature characteristics.

Fuel is a mixture of different hydrocarbons that do not all solidify at the same temperature. When fuel is cooled, an increasing proportion of wax crystals form in the fuel. The wax crystals can block fuel lines and filters, thus causing engine instability, power loss and eventually flameout, and their formation should therefore be avoided.

The fuel freezing point is commonly measured with the ASTM automated optical test method D5901-03. ASTM International is an organization which develops standards, amongst which are the fuel freezing point tests. This test method is based on the observation of wax crystals completely disappearing from a warmed fuel sample that was previously frozen. The method is used widely except for Russian and other Eastern-European fuels, for which the GOST (Russian state standard) method gives the temperature at which solid particles first appear during the cooling process. The ASTM method therefore affords higher margins.

The specification fuel freezing point depends directly on the level of distillation aimed for in its production. The higher the distillation grade, the lower the yield of fuel from the crude oil. Fuel of different specifications is found in different parts of the world, each with a different specification fuel freezing point. The main focus is on JetA1, primarily available everywhere except the United States of America, and on JetA, which is used there (see left-hand table).

### FUEL MIXTURES

When flying between areas where different fuel types are available, mixtures of fuel with different specification fuel freezing points will occur in the tanks. Experimental evidence has shown that fuel mixtures do not behave as ideal fluids and that the resulting fuel freezing point is commonly adversely affected. Airbus recommends avoiding mixtures in the outer, most exposed

tanks. JetA1 can be considered as having unaltered freezing characteristics up to a content of 10% of JetA, above that fraction results become unpredictable and the fuel freezing point should be considered to be that of JetA fuel.

### ACTUAL FUEL FREEZING POINT

When known, the actual fuel freezing point of the fuel carried onboard the aircraft may be retained as a criterion for cold fuel management in flight, if a monitoring process, including maintenance, dispatch, and crew procedures, has been set up in a way that is acceptable to local authorities. The process involves the retrieval of samples from the tanks through the drain holes after the refueling is completed. These are then put through jet fuel quality analysers, results can be radioed to the crew if not available before takeoff. Based on a fuel freezing point measurement survey conducted by a company involved in research in cold temperature behaviour of petroleum products at major US airports, a typical benefit of at least 3°C and up to 18°C can be expected from the implementation of such a monitoring process.

### MINIMUM INLET TEMPERATURE

Engines have an oil cooling system at their inlet, which uses the arriving fuel as a heat sink, thus warming it. Various system architectures and hardware leads to a varying specification of the minimum temperature that a given engine type can cope with. The minimum temperature is expressed as a margin versus fuel freezing point - the minimum

engine inlet temperature is the actual fuel freezing point with the manufacturers margin added to it (see right-hand table).

### FUEL HEAT MANAGEMENT SYSTEM LIMITATION

During flight, the fuel temperature quickly drops below the freezing point of water, of which a certain proportion is always contained in aviation fuels. This water can then form ice crystals, which could travel to the engine inlet filters and clog them. To avoid this, the fuel is warmed in the oil cooling system. For some engine types, a minimum fuel temperature below which take-off and/or flight is not permitted therefore results from the engine capability to warm up a water-saturated fuel flow, unless an anti-ice additive is used.

## Operational procedures

### GROUND PROCEDURES

Special attention should be paid to the fuel contained in the outer tanks before a flight through forecast cold atmosphere is commenced. These tanks may remain completely or partially filled with the cold reserve fuel from the previous flight. This may have an unrelated, but undesirable, effect of leading to wing surface icing after landing in a humid environment. More importantly, if partially filled, it may lead to high-proportion mixtures of different fuel types. Both can be avoided by performing a manual transfer of the outer tank fuel inboard during the taxi-in. If the outer tanks remain full with fuel of a lower



### Minimum inlet temperature

Pratt & Whitney A United Technologies Company	0°C
GE	0°C
Rolls-Royce	3°C
IAE International Aero Engines	4°C
A320F	4°C
A340	5°C

Fuel freezing point	
JetA	-40°C
JP5	-46°C
JetA1/JP8	-47°C
RT/TS-1	-50°C
JetB	-50°C
TH	-53°C
JP4	-58°C





freezing temperature than fuel locally available, it may be advantageous to keep that fuel there, since experience shows that a higher initial fuel temperature only has a delaying effect on the cooling process, but usually does not affect the minimum temperature observed in-flight. The benefit of the lower freezing point prevails in such a case.

**IN-FLIGHT PROCEDURES**

On aircraft equipped with a fuel temperature measurement system, an ECAM warning is triggered when the fuel temperature drops below the minimum acceptable temperature in that tank. The minimum acceptable temperature is not the same for all tanks. The temperature in the feed tanks (typically, but not exclusively, the inner tanks) may not drop below the minimum acceptable temperature limited by the engine inlet and the heat management system limitation, while the fuel in the remaining tanks may be allowed to reach the freezing point. The ECAM warnings are calibrated to the specification values of JetA and JetA1 fuel and request manual fuel transfers. The crew may delay the application of the procedures appropriately, if the actual fuel freezing point of the fuel carried is known.

The figure ‘tank transfer schematic’ shows an example for the A340-500 and -600, the FCOM 3.02.28 FUEL LO TEMP procedures request manual transfers:

- From outers to inners, when the fuel freezing point is reached in the outers
- Forward from the trim tank, when the fuel freezing point is reached in the trim tank
- From center to inner, when the minimum acceptable temperature is reached in the inners

**TAT INCREASE**

In addition to manual transfers, the procedure also recommends to increase the TAT (Total Air Temperature), which is the temperature measured on the structure of the aircraft. The TAT is derived from the outside or Static Air Temperature (SAT) and depends on the Mach (Ma) number:

$$TAT = SAT \times (1 + 0.2 \times Ma^2)$$

There are two means of increasing the TAT: increasing speed to increase aerodynamic warming, and reducing altitude to fly in warmer air. The TAT formula highlights that speed increase only has a marginal effect, while the exchange rate SAT to TAT is one to one.

To give an impression of the effect in time, both means are shown in separate variations from a basic scenario, which considers an A340-600 taking off at Maximum Take Off Weight (MTOW) flying from the US East Coast to East Asia on a great circle routing at Long Range Cruise (LRC) speed and on an optimum altitude profile. The aircraft is using JetA fuel with a specification fuel freezing point of -40°C. A statistical outside temperature profile is considered for this example, based on a 95% reliability for January, meaning that at any point during an actual flight in that month, there is only a 5% chance of encountering lower temperatures.

*The first variation* consists in flying at maximum managed speed (Ma 0.845 for this type) on a fuel-optimized profile. The figure “fly faster” shows the relevant parameters plotted against the ground distance, the basic scenario always shown in shades of blue and the variation case in shades of red/orange. The speed increase leads to a shift in the optimum profile, which is mirrored by the SAT profile, but even where the aircraft flies at the same altitude, a small increase in TAT can be observed. This increase delays the moment when the temperature drops below freezing point in the outer tanks by some 300 nautical miles (nm), but does not avoid the need for the manual transfer procedure from the outers to the inners. It does, however, succeed in maintaining the inner tanks temperature above or at the freezing temperature, which is sufficient for the Rolls Royce Trent 500 engines that equip this aircraft type. This comes at a cost: fuel burn at identical takeoff weight is increased by 7.9 tonne (t).

*The second variation* considers flying the whole distance at Flight Level (FL) 290. The figure ‘fly lower’ shows the large increase in SAT, which is mirrored by the TAT. The lower flight level succeeds in delaying the manual transfer by 800 nm and subsequently maintaining a comfortable margin of the fuel freezing point in the inner tanks. The cost of this variation is a fuel burn increase by 5.5t.

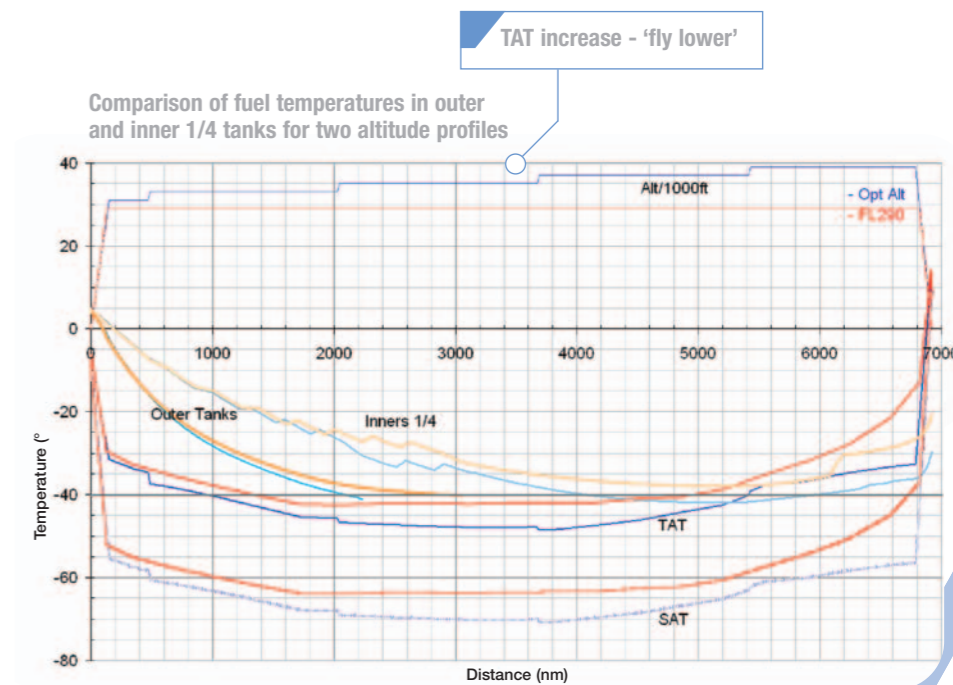
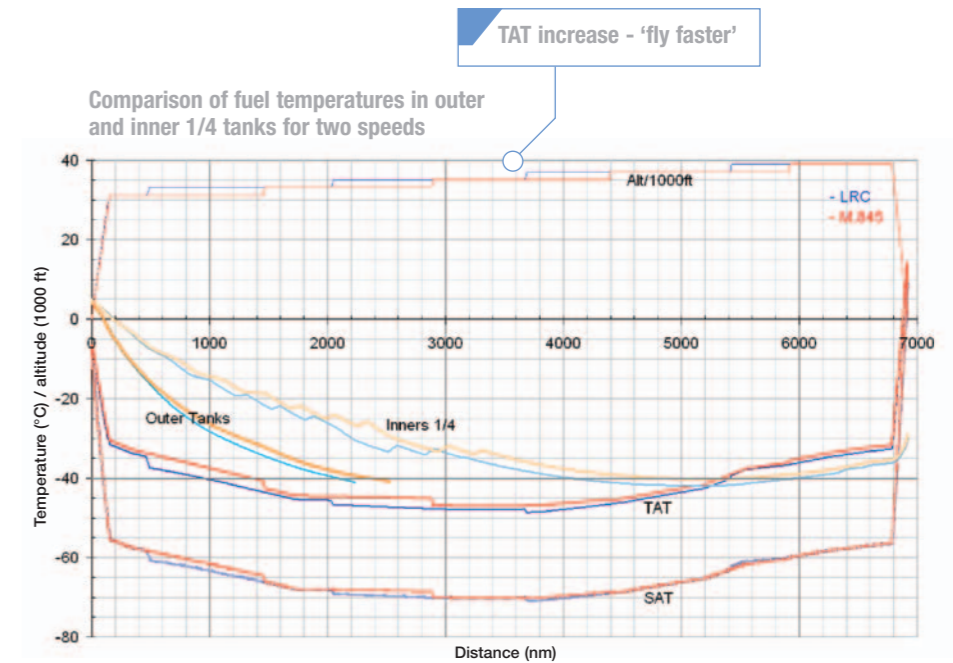

Tank transfer schematic

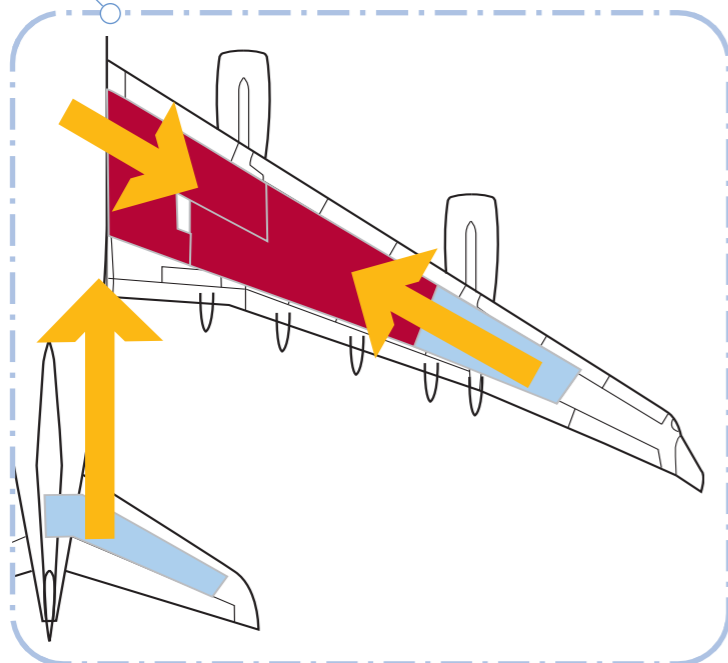



## Fuel temperature prediction software

As described in the previous section, while it is possible to manage cold fuel issues once in flight, an un-forecasted occurrence can lead to over-consumption and even diversion. In order to give airlines the ability to analyse a flight for its exposure to fuel freezing before it is flown, Airbus has designed the Fuel Temperature Prediction (FTP) software.

### PRINCIPLES

The FTP software relies on external data sources to obtain:

- Navigation data (waypoints, distance, time)
- Weather data (temperatures)
- Performance data (altitude, speed, fuel on board)

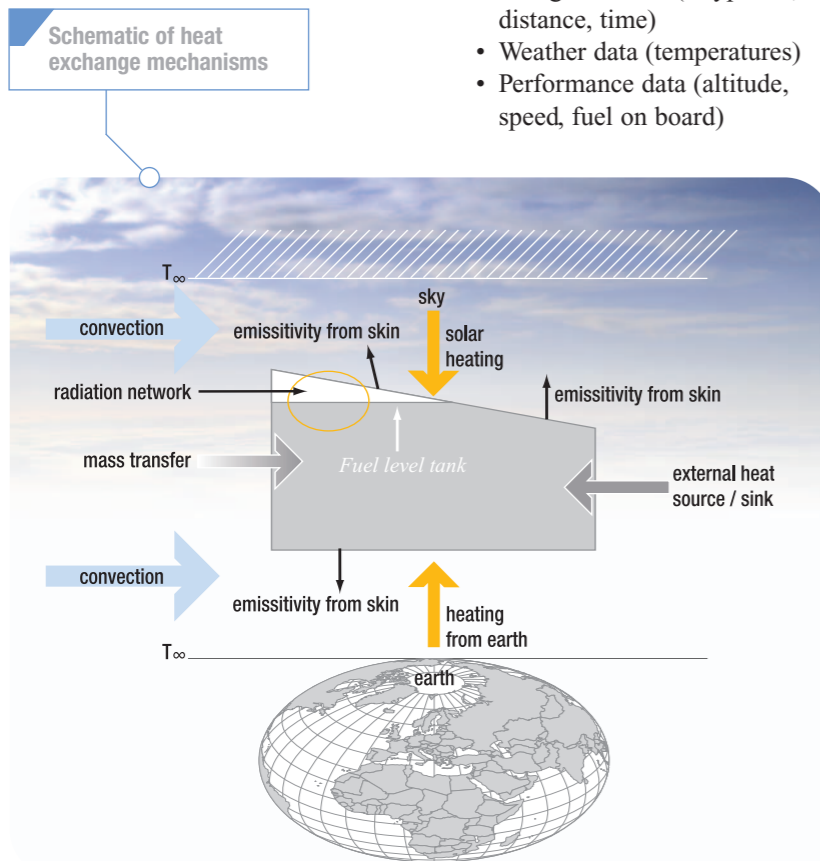

From this data, it determines the nominal fuel distribution and movement during the flight and simulates the effect of the various heat exchange processes, like convection, radiation, external heat sources and mass transfer. The result is a detailed output of the fuel temperatures in each tank at each waypoint, a summary that indicates whether the flight can be dispatched under the given conditions, whether any manual transfers were triggered during the simulation, and what the lowest temperature forecast in each tank is. This information allows the dispatcher to decide in an informed manner, which areas may have to be avoided on a critical flight.

### OPERATING MODES

The FTP can be used in two ways depending on the original source of the navigation, weather and performance data: the Flight Plan Analysis and the Sector Analysis.

### FLIGHT PLAN ANALYSIS

The Flight Plan Analysis uses an airline operational flight plan (or pilot log) as a basis for the computation. Operational flight plans are generated with Computerized Flight Planning (CFP) systems available from a number of providers. They run on different hardware, like PCs, UNIX or mainframe computers, or even remotely over Internet or similar connections, and they produce a document, which is highly customized by the operators to their specific needs.

One of the design constraints for the FTP software was therefore its

operability on a variety of platforms. At this time, stand-alone solutions are being developed for PC and UNIX under RS6000, in addition to the basic implementation, which is a complete solution included in the Performance Engineer's Programs (PEP) software suite.

An important aspect lies in the large variety of flight plans to be imported. This has been tackled in the PEP environment through the definition of a standard format, which uses XML (eXtensible Markup Language) and is a subset of the standard defined for the A380 Onboard Information System (OIS). The translation of the airline pilot log to XML requires the development of a customized tool. All the relevant information for this task is provided in the Performance Programs Manual (PPM), but assistance and even the development of such a tool is available as an Airbus service.

### SECTOR ANALYSIS

The Sector Analysis is designed to help assess the exposure of a city-pair to cold fuel issues on a statistical basis. For this task, some simplifications are made. The routing is assumed to be a Great Circle one; the performance on

the route is established with the Airbus Flight Planning (FLIP) software, which is also part of the PEP.

For the statistical weather data, a connection has been built to the NOAA GUACA (National Oceanic and Atmospheric Administration - Global Upper Air Climatic Atlas), which was compiled from data obtained in the 80's and 90's from the ECMRWF (European Centre for Medium Range Weather Forecasts). This database needs to be installed specifically to allow extraction of statistical data for monthly or seasonal exposure analysis.

Information and the database are available from the NOAA website: <http://navy.ncdc.noaa.gov/products/compactdisk/guaca.html>.

The FLIP computation results in a specific output, which can be directly imported into the FTP PEP user interface, through which the same type of analysis can be obtained as for a Flight Plan Analysis.

### APPLICABILITY

The FTP software is available for all A330/A340 Family aircraft and will be released for entry into service of the A380 and the A350.

## Conclusion

For some years monitoring of fuel temperatures for flights in cold atmospheres, such as trans-polar flights, has been normal and operational procedures to deal with this have been put in place. With the very long range A340-500 and A340-600, Airbus considered the increased exposure of these aircraft to low temperatures should be addressed at an earlier stage in the process than through the existing in-flight management procedures detailed in the FCOM and triggered by ECAM warnings.

This led to a review and from this came Airbus' recommendation that operators implement a fuel quality monitoring programme for exposed flights from airports where only high freezing temperature fuel is available and the creation of the Fuel Temperature Prediction (FTP) programme. The FTP enables the prediction and avoidance of cold fuel issues at the time of aircraft dispatch and is recommended for operators to support their operations on routes where such issues can arise.

### CONTACT DETAILS

**Lars Kornstaedt**  
 Airbus Customer Services  
 Group Manager  
 A380 Performance  
 Flight Operations Support  
 and Services  
 Tel: +33 (0)5 61 93 36 75  
 Fax: +33 (0)5 61 93 29 68  
[fitops.perfo@airbus.com](mailto:fitops.perfo@airbus.com)  
[lars.kornstaedt@airbus.com](mailto:lars.kornstaedt@airbus.com)





# AACT

## Airbus Active learning and Competence focused Training

A new approach to maintenance training

In the past, maintenance training mainly focused on theoretical knowledge acquisition. As part of Airbus policy of continually improving training courses, the maintenance training courses began to evolve, starting with the implementation of the MTD (Maintenance Training Device) in the course flow a few years ago. The MTD allowed trainees to gain practical skills before having real practice on an aircraft.

A further step in this process sees the AACT (Airbus Active learning and Competence focused Training) course being introduced. The AACT course is a new approach developed by Airbus for training maintenance technicians.

The main innovation in this new approach is the intensive use of new Airbus simulation tools, like the M/FTD (Maintenance/Flight Training Device) and the virtual aircraft, which enable maintenance tasks to be performed throughout all their steps.



**Christèle Bertrand**  
Airbus Customer Services  
Training Project Leader  
Training & Flight Operations Support and Services

### AACT objectives

The AACT innovations focus on two central aspects:

#### ACTIVE LEARNING

Training experts generally agree that, whatever the subject is, most people learn better when they are actively involved during training. With AACT, aircraft maintenance technician trainees will participate more actively in the course, and will not be passive recipients of theoretical knowledge only. This active participation in the classroom is especially important for technicians accustomed to involvement in the actual operation of aircraft.

#### OPERATIONALLY ORIENTED TRAINING

The obvious objective of any maintenance training course is to train people to be competent in their job, that is: maintaining and operating aircraft safely and efficiently.

Adaptation and evolution of such training is always necessary to handle the latest aircraft technologies and maintenance practices. In the newest Airbus aircraft, especially the A380, the aircraft systems are more integrated and sophisticated maintenance tools are provided for maintenance technicians. To follow these aircraft evolutions, AACT training will be more operationally oriented than before and not only focused on aircraft system knowledge.

### New simulation tools

The key elements of AACT courses are two new training tools: the M/FTD and the virtual aircraft.

**The M/FTD** is a training tool that is common to flight and maintenance training. It replicates the real aircraft cockpit with PC (Personal Computer) screens and simulates the aircraft systems and maintenance BITE (Built In Test Equipment).

Two versions of the M/FTD are available:

- The 3D M/FTD, which is built with touch-screens displayed as in a real cockpit, plus some essential aircraft hardware equipment (like Flight Control Unit and Multipurpose Control & Display Unit)
- The 2D M/FTD, which is a lighter version of the M/FTD and consists of only two screens, without the aircraft hardware equipment

**The virtual aircraft** tool is a new Airbus application, based on virtual reality and running on a normal PC. It simulates the whole aircraft and enables trainees, in a three-dimensional on-screen environment, to walk around the aircraft and locate aircraft components or visit aircraft areas, such as the avionics bay or main landing gear bay. When linked with the M/FTD, maintenance actions can also be simulated in the virtual aircraft.



Both of these tools will be intensively used in the AACT programme to perform the practical sessions, as well as to support the theoretical part.

Virtual aircraft



M/FTD





## AACT training programme

For theoretical sessions, the aircraft systems will still be described using classical Computer Assisted Training (CAT) lessons, whereas the system operation, control & indications will be demonstrated with the 2D M/FTD. This use of the M/FTD in the classroom will allow the instructor to use the M/FTD simulation to demonstrate systems with more flexibility and realism for the benefit of trainees.

During training the main aircraft components will be located and described in the virtual aircraft, avoiding unnecessary immobilization of an actual aircraft, which can be difficult and costly. Each trainee will also be able to use the virtual aircraft freely at any time in the training to review components and locations.

Practical sessions of servicing and troubleshooting maintenance tasks (Aircraft Maintenance Manual and Trouble Shooting Manual tasks) will be performed by trainees on the M/FTD coupled with the virtual aircraft and using the electronic aircraft documentation. This link between both tools allows simulation of the whole aircraft (inside and outside), and not only the cockpit as was the case in previous generation training devices. With these tools, trainees are able to perform

a task in a more realistic way and as a whole, from cockpit actions such as post-flight report consultation and fault isolation through the Multifunction Control and Display Unit, to action on an aircraft component, like removal and installation of a suspect unit, then back to the cockpit to perform BITE tests of the installed unit.

This complete simulation environment brought by the M/FTD and virtual aircraft, coupled with the aircraft documentation access, provides an efficient and secure way to conduct major practical exercises when compared to a real aircraft where all tasks cannot be actually and completely performed by all trainees. The virtual aircraft answers the main issues encountered on real aircraft, such as difficulty to simulate faults, remove and replace components, the safety risk for trainees, time necessary to allow each trainee to perform tasks and so on.

## New learning environment

The 2D M/FTD and the virtual aircraft will be installed in the classroom, directly on the trainees' desk, to maximize training benefits from the tools. This easy access to the tools will allow a greater mix of theory and practice than was previously possible and will enable explanation of systems theory step by step, prior to practical applica-

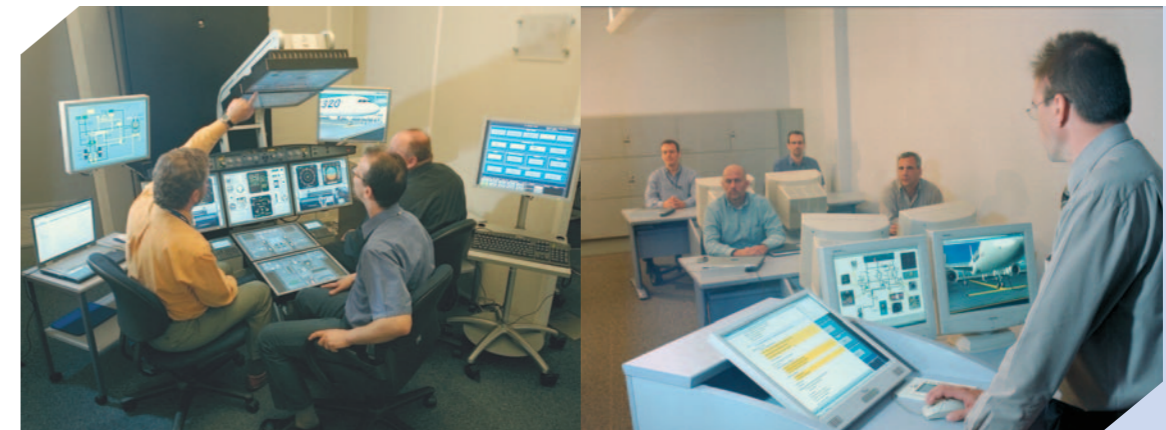

tion. Trainees will therefore become more and more active in the learning process, at every stage of the training. Furthermore, they will no longer need to wait to the end of the theoretical part to interact in the course and perform the tasks by themselves.

In the AACT course, human factors training will be integrated and will no longer be considered as separate training. Human factor issues will be integrated with technical and operational training and spread in the different types of sessions: theoretical lessons and operational scenarios.

## Course deployment

The AACT approach will be progressively applied to all Airbus maintenance courses. The first course using the AACT philosophy is the A320 Family maintenance course and will be run in autumn 2005 in the Hamburg training centre. After this, AACT courses will be implemented in 2006 for the first A380 maintenance course, and then on A330 and A340 Family courses.



### CONTACT DETAILS

**Christèle Bertrand**  
Airbus Customer Services  
Training Project Leader  
Training & Flight Operations  
Support and Services  
Tel: +33 (0)5 61 93 25 07  
Fax: +33 (0)5 61 93 20 73  
christele.bertrand@airbus.com

## Conclusion

Using the latest simulation tools like M/FTD and virtual aircraft and providing an easy and intense access to them for trainees, allows in a sense to bring the aircraft into the classroom. The AACT course, combining the efficiency of such tools and a more active learning environment will significantly enhance the quality and efficiency of maintenance training, and as a consequence the safety and efficiency of maintenance operation on aircraft.

**AIRBUS**







# T2CAS

## Terrain and Traffic Collision Avoidance System

Upgrading your aircraft by combining TCAS and TAWS in one unit

Airbus aircraft have been equipped with the GPWS (Ground Proximity Warning System), which was followed by the Enhanced Ground Proximity Warning System (EGPWS) certified in 1997 to warn of terrain collision hazards. In addition, Traffic alert and Collision Avoidance System (TCAS) has been installed to warn of aircraft mid-air collision hazards.

Since February 2005, Airbus is offering a solution integrating both functions: the T2CAS (Terrain

and Traffic Collision Avoidance System) which combines the Terrain Awareness Warning System (TAWS) currently named EGPWS, and the TCAS in one unit.

As an alternative to the currently certified TAWS and the TCAS, the T2CAS allows maintenance cost reductions as well as a global weight decrease.



**Christine Vigier**  
Airbus Customer Services  
Senior Design Manager  
Airbus Upgrade Services

### TAWS TCAS

The TAWS generates alerts to inform the flight crew that the terrain ahead of the aircraft on its intended flight path poses a hazard to safe flight.

TAWS is intended to warn the flight crew of hazards that could result in controlled flight into terrain with sufficient time for them to assess the situation and determine the best remedial action.

TAWS is mandated by the European Aviation Safety Agency for all types of aircraft from the first of January 2005 (end of March 2005 for the Federal Aviation Administration).

The TCAS function is an independent, onboard collision avoidance system designed to assist flight crews in avoiding midair collisions.

When activated, TCAS acts as a backup means of collision protection from other aircraft that have an Air Traffic Control Radar Beacon System (ATCRBS) or Mode-S Transponder.

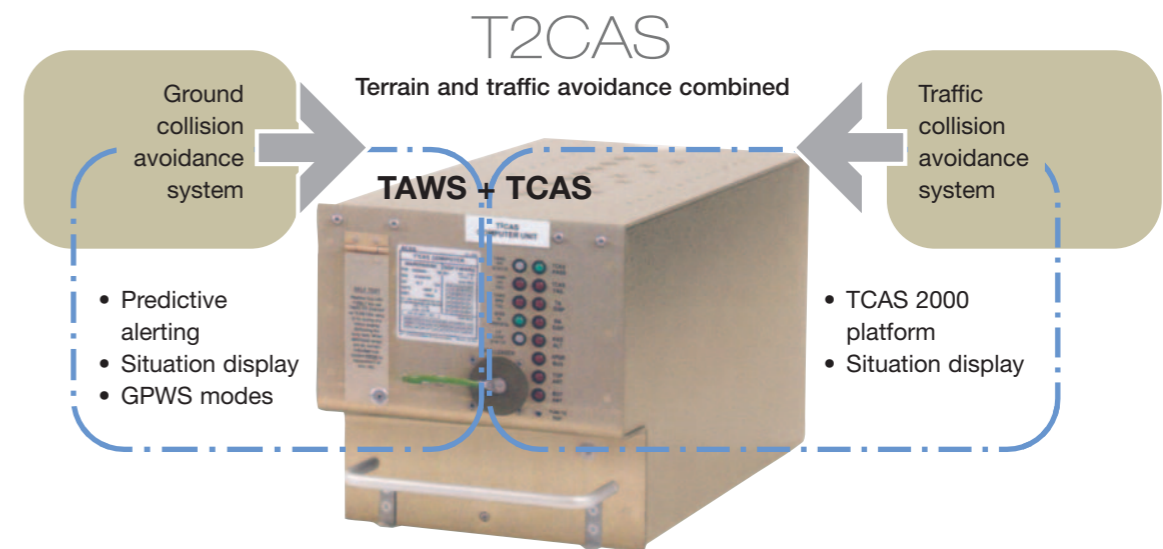

### TAWS functions

The T2CAS-TAWS part specification is a class A TAWS per TSO C151b standard. It therefore provides suitable aural and visual warnings to alert the crew of any hazardous situation with respect to the terrain ensuring the following functions:

- Mode 1**  
Excessive rates of descent
- Mode 2**  
Excessive closure rate to terrain
- Mode 3**  
Negative climb rate or altitude loss after take off
- Mode 4**  
Flight into terrain when not in landing configuration
- Mode 5**  
Excessive downward deviation from an ILS (Instrument Landing System) glideslope

**A Forward Looking Terrain Avoidance (FLTA) function**  
The FLTA function looks ahead of the aircraft along and below the aircraft lateral and vertical flight path and provides suitable alerts if a potential terrain threat exists. The FLTA function on the T2CAS is based on a worldwide terrain database.

**A Premature Descent Alert (PDA) function**  
The PDA function of the TAWS uses the aircraft's current position and flight path information, determined from a suitable navigation source and airport database, to determine if the aircraft is dangerously below the normal approach path for the nearest runway as defined by the alerting algorithm, visual and aural discretes signal for both caution and warning alerts, (a specific visual and aural discrete signal is sent to the flight crew for each type of alert, either caution or warning).



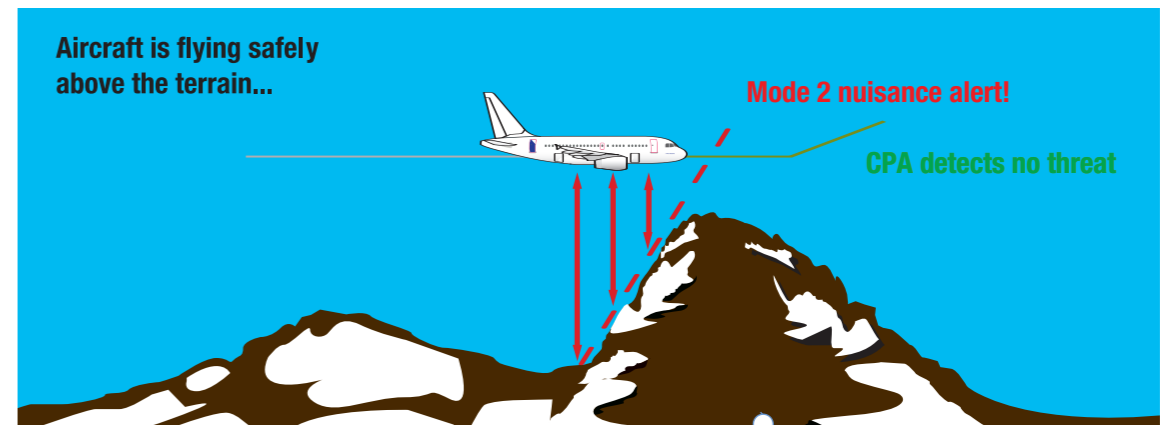
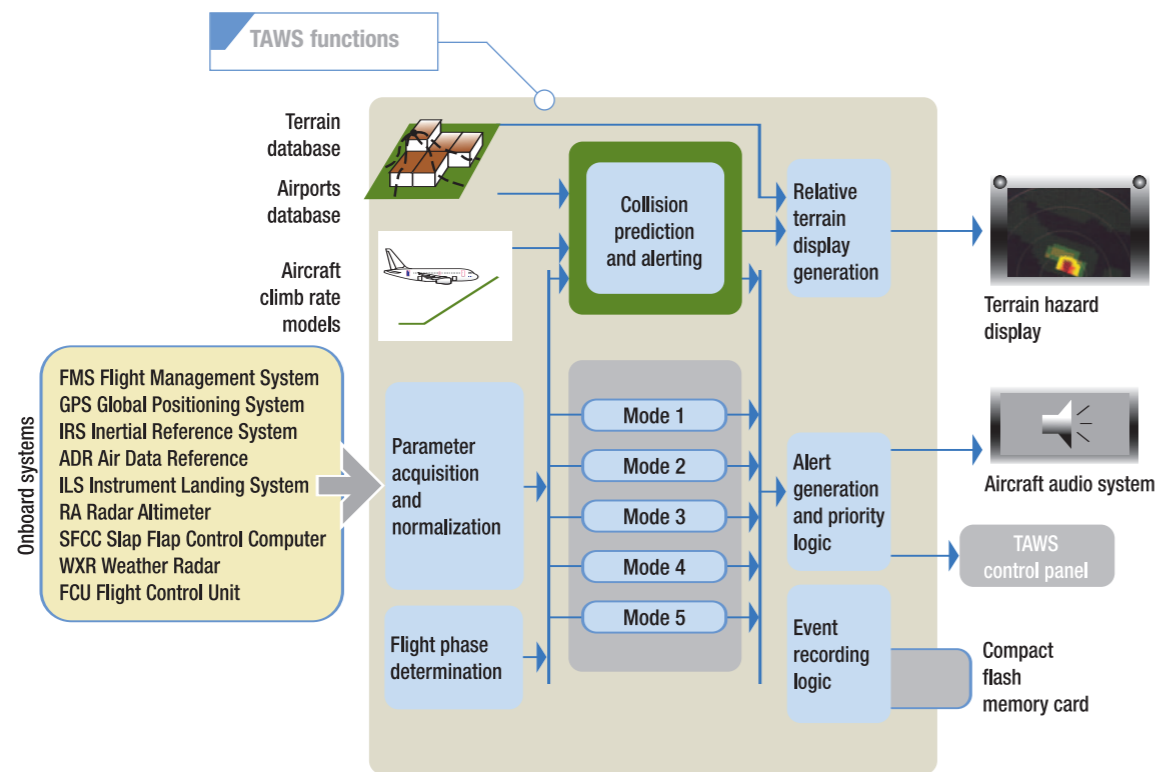

### TCAS functions

The T2CAS-TCAS part corresponds to a TCAS II change 7.0 in compliance with existing regulations. It is functionally, as well as operationally, equivalent to any TCAS II change 7.0 installed in aircraft in-service.

The system has 3 main functions:

- Detects close aircraft (equipped with Air Traffic Control (ATC) transponders),
- Displays possible collision aircraft,
- Activates vertical orders in order to avoid collision.

The system is designed to generate safe separation between aircraft predicted to be on collision trajectories, while minimizing ATC clearance deviations or excursions.

TCAS continually surveys the airspace around the host aircraft by actively interrogating and seeking replies from the transponders of other aircraft in the vicinity. It recognizes replies from aircraft equipped with ICAO Mode-A, Mode-C, or Mode-S transponders and determines the range, relative bearing, and the relative altitude of the other aircraft. Using this information, TCAS predicts flight paths, estimates the separation at the closest point of approach (CPA), and determines if a potential conflict exists. If a conflict is detected, the system gives guidance for the optimum vertical avoidance manoeuvre.

The TAWS part of the T2CAS uses the same cockpit interface as for EGPWS. In comparison to EGPWS the T2CAS-TAWS offers some significant enhancements:

- Certified FLTA (Forward Looking Terrain Avoidance) and PDA functions are ensured by the CPA (Collision Prediction and Avoidance) function in T2CAS. Based on actual aircraft climb capability, the CPA offers the following enhancements:

- A new aural warning 'Avoid Terrain' alerts the flight crew that the climb capability of the aircraft may not be sufficient to clear the terrain.
- A corresponding red and black crosshatched area on ND depicts the terrain concerned.
- The nuisance prone mode 2 (solely based on measured radio altitude) is inhibited while FLTA function (the CPA function previously described) is operative.

### TCAS separation areas

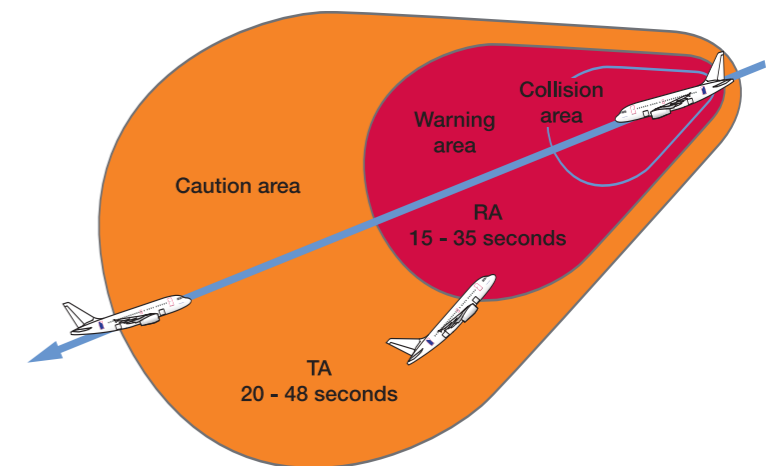

TA: Traffic Advisory  
RA: Resolution Advisory

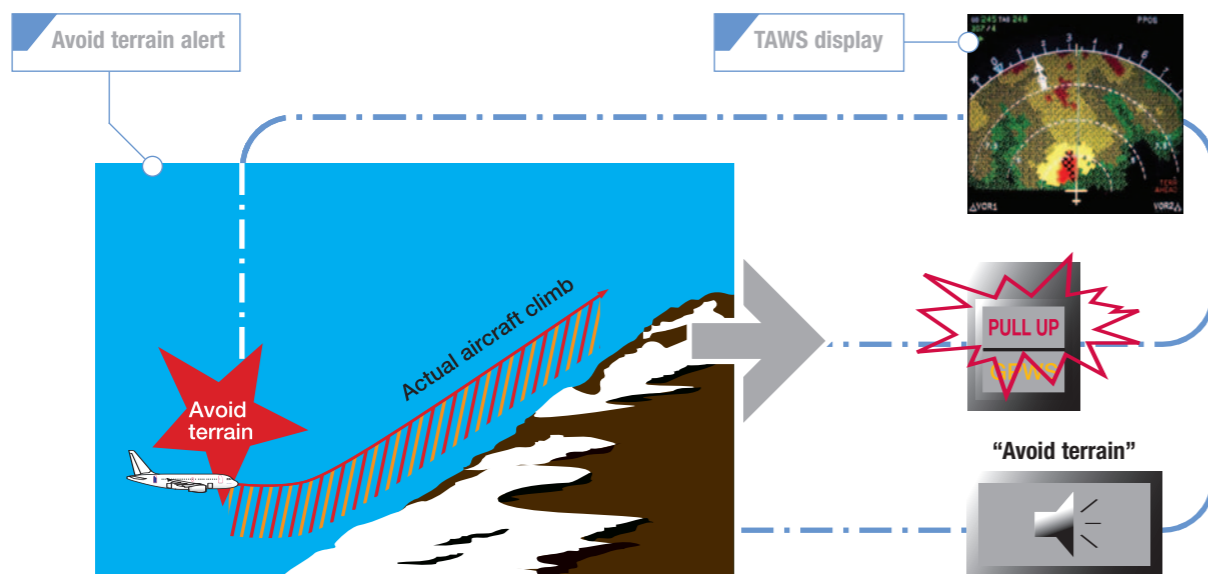



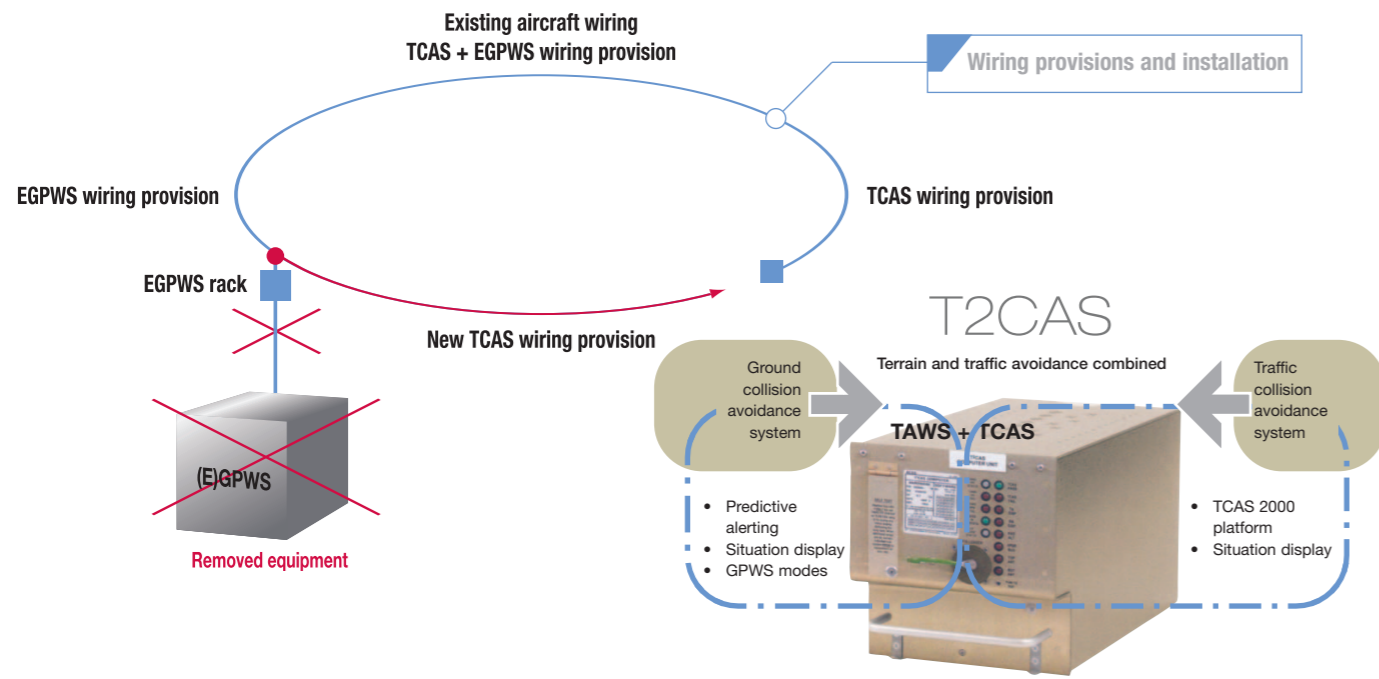

## Wiring provisions and installation

Installed at the same rack as the TCAS computer, this upgrade solution is easy to integrate in the avionics compartment as it uses the same peripheral computers as the EGPWS.

Airbus delivers 2 Service Bulletins and the related kits: The first is for wiring provisions and the second for T2CAS installation. As an option, the aircraft wiring provisions for T2CAS can be directly installed on

the production line for all programmes.

To retrofit the aircraft with a T2CAS, the following prerequisites have to be installed if not available on the aircraft:

- EGPWS provisions and the related peripheral computers,
- TCAS Change 7.0,
- Compatible mode S ATC transponder,
- Pin programming according to the aircraft configuration,
- T2CAS computer and associated antennas.



# A new concept for Service Bulletins

## addressing airline expectations for Service Bulletins

Airbus has launched a 'Service Bulletin New Concept' (SB New Concept) project, which has the objectives to:

- Improve SB communication
- Ease SB understanding
- Reduce airline engineering SB workload
- Match SBs with airline practices
- Minimize aircraft ground-time
- Contribute to improving vendor performance

The project arose from one core idea that led Airbus to a new approach to SBs: there is a real need to reduce airlines engineering workload generated by SBs.

## Conclusion

The combination of the TCAS and TAWS into one Line Replaceable Unit (LRU) provides an innovative and flexible alternative to the two separate LRUs of the existing systems. Combining them into T2CAS gives significant enhancements over some of the functions of the existing systems, provides a weight decrease and furthermore reduces maintenance costs for operators. Since February 2005, Airbus can provide a certified solution for all

types of Airbus aircraft (except A300 B2/B4) since the first embodiment for each programme has been realized between February and April 2005: An A320 was retrofitted at the end of February, an A340 at the beginning of March and an A300-600 at the end of April.

The system item is scheduled to be available via the Upgrade Services E-catalogue at the beginning of 2006.

### CONTACT DETAILS

**Christine VIGIER**  
Airbus Customer Services  
Senior Design Manager  
Airbus Upgrade Services  
Tel: +33 (0)5 67 19 02 17  
Fax: +33 (0)5 62 11 08 47  
christine.vigier@airbus.com



**Annick Pedron**  
Customer Services  
Manager Process, Method & VSB Monitoring  
Service Bulletin Department



## A new approach to SBs

The project is a completely new approach to SBs and was initiated by key messages from the airline community, which led Airbus to analyse what could be improved and identify a new concept for SBs. The decision to launch the project was taken with some airlines and workshops were organized in 2004 to ensure the SB New Concept will really match airlines expectations.

Working together with these airlines, Airbus identified enhancements to apply to SBs to achieve the project objectives and defined future services to be offered. This was done by a collaborative approach with the involved airlines, which allowed Airbus to understand and analyse the SB integration process on the airline's side (Refer to figure 'A generic view of SB processing at airlines').

This joint analysis of airline activities resulting from the receipt of SBs allowed Airbus to understand any difficulties the airlines could face with handling SBs and determine what should be changed, what improvements should be required and what new on-line SB services could be offered to reduce airline SB activities and make them easier.

A tremendous number of ideas were generated by the analysis and services were identified that could help in several areas of the airline process, not only in the 'engineering preparation' area.

The future services defined will cover the different steps of the SB integration process, from receipt to embodiment and cover mainly Airbus SBs, but will also cover vendor SBs to some extent and embrace the project objectives.

## Improve SB communication

Airlines would like improved communications with Airbus and are also interested in sharing experience with the general airline community. This will be achieved with a service called 'General on-line services', which started with the 'Event Notification' service available on Airbus On-Line Services since September 2004. Airlines registering to the 'notification subscription' are then notified by e-mail whenever SBs are made available on Airbus On-Line Services (Refer to figure 'How to access event notification services' on the following page).

The next step, by the beginning of 2006, will be an SB on-line reporting service to make the SB accomplishment reporting activity easier for airlines.

After this, an SB FAQ (Frequently Asked Questions) and forum will be introduced. This will be done as a second step of the Airbus FAIR (Forum for Airline Issues Resolution) project in the third quarter of 2006. This service will offer a forum for discussion, so that airlines can share experience with other airlines on SB embodiment. It will also provide an area where Airbus will inform airlines of queries received and their associated answers, to proactively anticipate similar queries from other airlines.



A generic view of SB processing at airlines

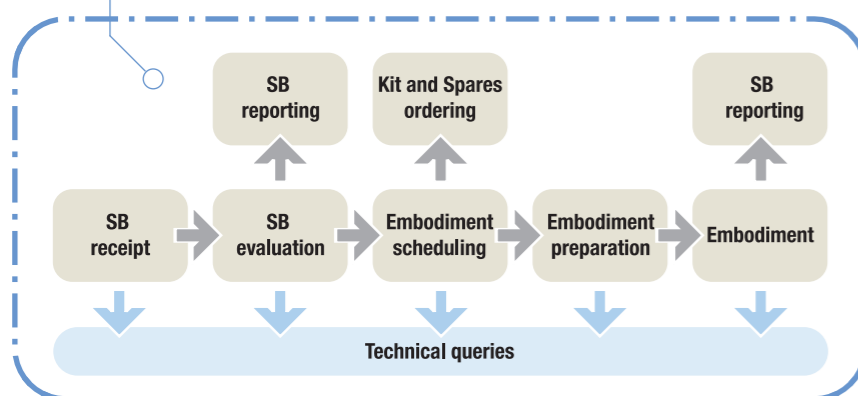

How to access event notification services



## Ease SB understanding

SB implementation can be sometimes time consuming and airlines would like Airbus to make SBs easier to understand to reduce this.

For some complex SBs an additional document called an 'SB booklet' has been already introduced. This booklet describes a complete modification in photos taken during an SB validation on in-service aircraft (Refer to figure 'Extracts from SB booklets available on Airbus On-Line Services').

These are available now on Airbus On-line Services and are accessible from the 'Service Bulletin Information' area of the 'General Information' service (Refer to figure 'How to access SB booklets on Airbus On-Line Services' on the following page).

This approach will be further enhanced in 2006 with the integra-

tion of photos into SBs to complement the current illustrations. The advantage of photo integration is to better show the area concerned by a modification or inspection.

The possibility of using a digital mock-up to build movies showing part of the modification for complex SBs is also under study. This is feasible because Airbus designs new aircraft models using 3D computer aided design, so the 3D views could be used to implement a library of movies. This will be applicable only for new aircraft programmes.

## Reduce airline engineering SB workload

This area is the major one of interest for airlines and will be covered by an enhancement known as 'fully engineered SB'. SBs are sometimes quite complex and can also cover several different aircraft configurations. As a result, airline

engineers may spend a significant amount of time identifying what impacts a specific aircraft and reworking an SB into smaller tasks for engineering orders to enable accomplishment on that aircraft. Man-hours can be saved by providing airlines with a document in line with their working practices in the shape of a 'fully engineered SB' – meaning an SB ready for an airline to use and designed in accordance with engineering orders.

The 'fully engineered SB' objective is to adapt SBs to the airlines

way of working and will be addressed by Airbus in three ways:

- Configuration management
- Detailed task breakdown
- Introduction of hyperlinks

## CONFIGURATION MANAGEMENT

This will ease access to SB data by introducing management by configuration, which will harmonize SB contents and allow data filtering. Using it, airlines can easily select, consult, extract and download data concerning their own fleet or individual aircraft.

How to access SB booklets on Airbus On-Line Services



### DETAILED TASK BREAKDOWN

Segmenting accomplishment instructions into smaller tasks will accommodate shift work organization and improve flexibility at embodiment level. Tasks will be also enriched with information such as associated kits, location, man-hours and skills as this type of information is necessary to organize work on an aircraft.

### HYPERLINKS

Hyperlinks will allow navigability between SBs and referenced documents, such as the Aircraft Maintenance Manual.

Implementation of the 'fully engineered SB' is foreseen in several waves, with three major steps, to give initial benefits immediately.

The first step introduces management by configuration. SB accomplishment instructions are structured by configuration to ease access to data applicable to a specific configuration (Refer to figure 'Management of accomplishment instruction per configuration') and will be broken down according to the type of work and the work area. Whenever possible, breakdown will be in tasks of about 3 to 4

hours to enable planning of work to fit into shift patterns. This breakdown approach is now being applied for any new Airbus SB. For very complex SBs it allows drastic reduction of the time required to prepare work instructions.

The second step, planned for the first half of 2006, will give access to customized SB data, filterable in accordance with fleet configurations.

The third step, based on a new SB product structure, will further enhance access to airline data and will enable navigability with other technical manuals through new on-line services. This service is planned to be operational beginning 2007.

### Minimize aircraft ground-time

The 'fully engineered SB' will minimize aircraft ground-time to some extent and it will also be enhanced by other innovative services, such as one known as 'other applicable SBs'. This will enable retrieval of SBs that could be embodied at the same time as a given SB as they involve the same zones or access. This offers the opportunity to reduce the global time required for accomplishment of these other SBs if they were performed separately.

### Improved supplier performance

The airline community expects Airbus to be more involved in supplier activities and contribute to a good supplier performance. On-line access to Vendor Service Bulletins (VSBs) covered by an Airbus SB has been operational on Airbus On-Line Services since April 2005, giving a more efficient, easier access to VSBs via a single point of contact (Refer to figure 'How to access VSB on Airbus On-Line Services').



Management of accomplishment instruction per configuration

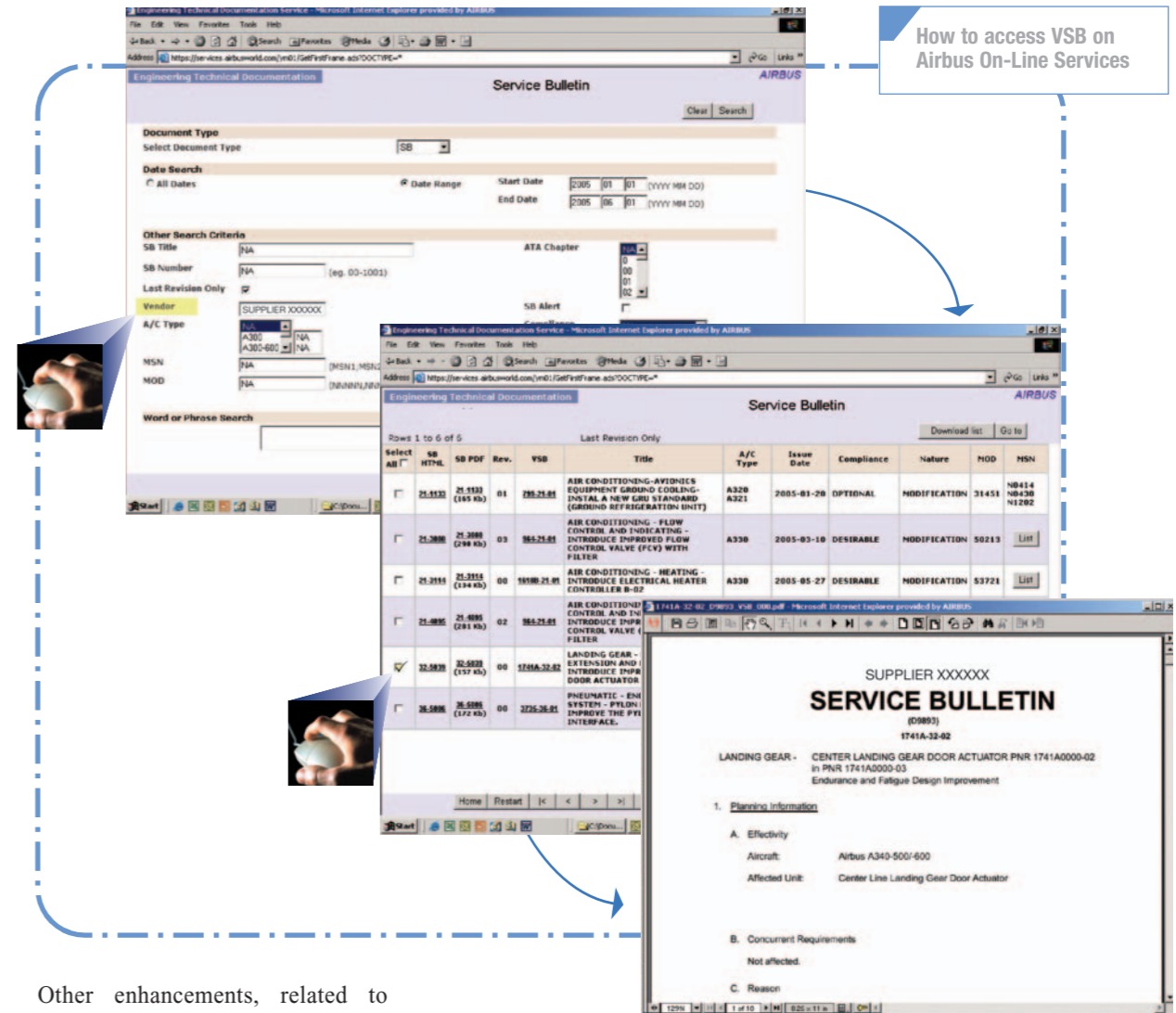
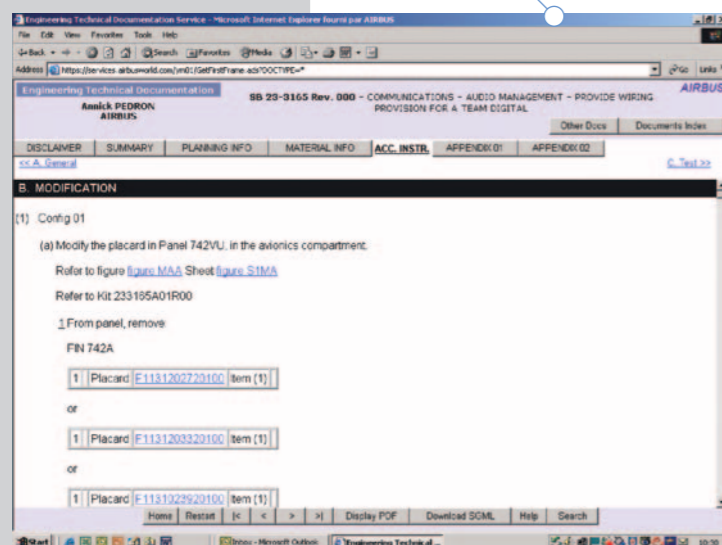

How to access VSB on Airbus On-Line Services

Other enhancements, related to Airbus internal processes, are also planned with a VSB on-line scrutiny to improve VSB timeliness and accuracy. Airbus is also working with suppliers to make available by the end of 2007 all VSBs on Airbus On-Line Services and not only those covered by an Airbus SB.

**CONTACT DETAILS**

**Annick Pedron**  
 Airbus Customer Services  
 Manager Process, Method &  
 VSB Monitoring  
 Service Bulletin Department  
 Tel: +33 (0)5 61 93 28 59  
 Fax: +33 (0)5 61 93 42 51  
 annick.pedron@airbus.com

## Conclusion

Continuous improvement is one of the key objectives of Airbus Customer Services and the SB New Concept is a concrete example of this. The concept has been defined and implemented in partnership with airlines to ensure SB and associated services enhancements fully match airline expectations.

The concept is already providing some benefits in SB activities and, as future waves of enhancements are implemented, numerous additional benefits will become available to airlines to enhance the efficiency and reduce the costs of their SB activities.





# RFID

## Radio Frequency IDentification

Supporting the aircraft supply chain

Around the world, organizations mandate their business partners to tag their goods with Radio Frequency Identification (RFID) devices. For example, one of the biggest US supermarket chains insists that its top suppliers tag their crates with RFID from 2005 onwards. RFID is an automated identification system, which allows touch free identification of goods or shipments within process control, tracking and tracing as well as functions in many other areas of the supply chain.

RFID is used today in many aspects of daily life, such as access passes to security areas, toll payment stations, logistics and anti theft protection. However, the technological basis applied for such purposes is different from the one needed for the aviation industry.

This article provides an update on Airbus RFID activities subsequent to the article published in FAST 30. It gives an overview of Airbus RFID activities and achievements and the positive effect of RFID on the aircraft spares supply chain.

The article further describes the individual steps taken towards a total integration of RFID into a companies ERP (Enterprise Resource Planning) environment and gives information on Airbus leading industry activities to define RFID standards.



**Andreas Teufel**  
Airbus Customer Services  
Director Spares Marketing/On-site Support  
Spares Support and Services

RFID tags are essentially microchips, and mostly referred to as transponders, tags or RFID chips. The RFID tags always listen for radio signals sent by RFID readers. When a tag receives a radio query, it responds by transmitting its unique identification frequency code and data back to the source of the radio signal. Depending on the required range, the RFID tag works either without its own energy source (passive system) or with its own energy source (active system). Passive RFID tags are powered by the radio signal that wakes them up and triggers an answer.

Today's conventional use of RFID identification requirements are mostly of low data density, while the benefit for the aviation industry lies in the high data density that is needed for tracing.

### Data density types

Which type of data density is applied depends on the actual task requirements.

#### LOW DATA DENSITY

Low data density is mostly used for simple information listing, i.e. informing the RFID reader of the number of identical items within one package. Long distance reading for total data capture is possible. Communication with several tags simultaneously under an anti collision system is also possible. The anti collision system enables the reader to receive data from each tag on a one-by-one basis. When multiple tags are in the same radio frequency and transmit data together, the reader communicates with the tags to prevent the collision of data. This is, for example, accomplished by transmitting a gap pulse.

#### HIGH DATA DENSITY

High data density is used for tracing of goods when a complete, unambiguous part history is needed, as in the aviation industry. Each component that is traced has a

unique identification and history. It is not sufficient to know the number of units received, but more specifically: where did the part come from, where was it installed, how many hours was it operated, who repaired it, who installed what type of software last and so on. It requires short distance reading to ensure accurate readings, with communication taking place exclusively with a single tag at a reading distance within centimetres.

The chips used in Airbus applications are set today at a capacity of 4 kilobytes with dimensions of just 8 millimetres (0.31 in.) in diameter and can be flush metal mounted.

### RFID benefits

The aviation industry is similar to other organizations in looking for efficiency enhancements and cost savings and the supply chain for spares, tools and similar goods is recognised as an area offering potential. Interfaces within supply chains and the associated administration and information flow are areas where efficiency can be significantly improved through using RFID functionality.

Among the many advantages of RFID over the widely used bar coding is its ability to read the data contained in the chip, without line of sight, with the data instantly transferred by radio waves. This allows, for example, reading of periodical check information of oxygen masks installed in an aircraft without the need to take them out from behind ceiling panels.

Suppliers can use RFID to ensure parts are genuine, reducing the risk of unapproved parts entering the supply chain.

Data recorded, such as repair history or cycle time information, are shared so that the integrity and dynamic history can be established, leading to increased maintenance reliability and aircraft safety.

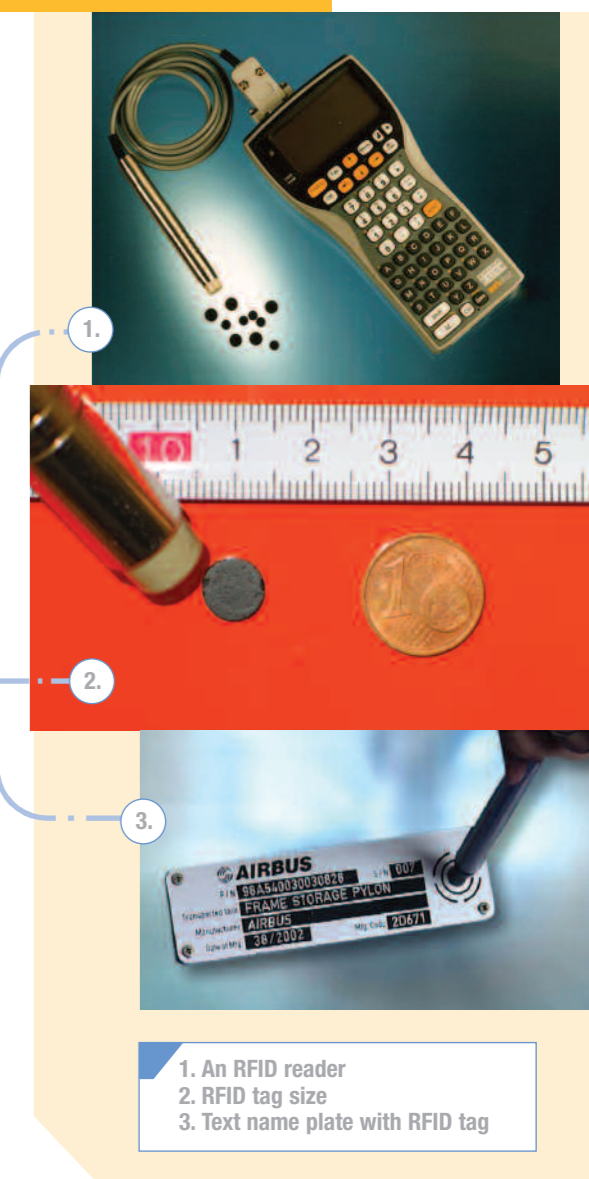

1. An RFID reader  
2. RFID tag size  
3. Text name plate with RFID tag

**The RFID frequencies applied in different countries of the world:**

- The frequency used for low data density is from 860 to 950 MHz and typical deployment is for transport crates, logistic systems and warehousing.
- The RFID frequency used for high density is 13.56 MHz and is currently the sole frequency recognised and used as standard frequency for RFID worldwide.



## Radio frequency applications for RFID

### High Frequency (HF):

13.56MHz  
Today's sole worldwide standard RFID frequency

### Ultra High Frequency (UHF):

862 - 960MHz  
Standard frequency range useable for RFID, but currently not commonly applied worldwide.

• USA	902-928MHz
• Europe	865-868MHz
• Japan	950 - 956MHz
• Korea	910 - 914MHz
• Australia	923 - 928MHz
• China	approx. 900MHz

## Airbus' RFID chronology

**1997** - RFID deployment on Airbus tools for loan service business

**1998** - Development of RFID infrastructure and application

**1999** - Further gain of practical experience with operation under RFID

**2002** - Airbus initiates global standardization activity on RFID in aviation

**2003** - Airbus developed book of technical requirements for RFID

**2003** - ATA Spec 2000 chapter 9 was renamed "Automatic Identification & Capturing"

**2003** - Successful onboard aircraft test of RFID with resulting unlimited approval by German National Airworthiness Authorities (LBA)

**2004** - ATA Spec 2000: First RFID section with basic requirements embodied

**2005** - ATA Spec 2000: Mandatory data elements are defined

**2006** - Airbus Singapore warehouse to operate under RFID

While marking, tracking and sharing is common in many industries, the really important aspect for the aviation industry lies in RFIDs potential to trace - addressing essential safety aspects of parts originality. Tracing means capturing the current status of the part and creating its history records.

Typical traceable information includes:

- Part history and status, i.e. modifications, software versions
- Calibration
- Certification
- Authorized documents
- Updated information
- Unambiguous part identification

The advantages of tracing have led to RFID being widely introduced to manage supply chains from manufacturing, to shipping, to stocking store shelves.

The Air Transport Association (ATA) has also added an RFID standard to its Spec 2000 e-business applications for the aviation parts industry.

## Airbus vision for RFID

Airbus recognized the potential of RFID early on (see "Airbus' RFID chronology") and since then has actively led RFID activities in the aviation industry.

The necessity for permanent parts

marking for safety and authenticity reasons is recognized, though these can depend on the part and its environment. Therefore, permanent parts marking must be applied according to the differing needs, Airbus actively promotes available technologies such as text nameplates, and barcodes and is researching the possibilities of the RFID technology.

The benefits of RFID described previously mean that the whole process can be made quicker, more efficient and less costly. Therefore, Airbus is investigating the possibilities of deploying RFID on future aircraft programmes and will continue to lead industry activities to standardize RFID, develop new projects and finally promote widespread application of RFID technology where it is applicable under security and cost effective aspects.

## SOFTWARE ASPECTS OF RFID

Special read/write software for RFID applications was created to read, write, and add data on the chip. As the software is independent, it can be used with any system allowing integration into all existing data processing systems.

Special software is also required to transfer the data into companies Enterprise Resource Planning system. Airbus uses a specially developed interface for RFID data exchange with Airbus' ERP system.

The integration is fully applied and transferable to other RFID users that want to link RFID to ERP systems.

## AIRBUS INITIATIVES FOR RFID STANDARDIZATION AND DEPLOYMENT

The most important objective for RFID use is to define an international standard for the data fields and frequencies.

Airbus leads the international standardization activities through active participation at steering boards and regular industry conferences.

Airbus also participates in the ATA Spec 2000 Chapter 9 Task Force, Permanent Bar Code Parts Identification and actively pursues a continuous dialogue with customers, suppliers and other aircraft manufacturers.

Airbus main objectives are:

- Define harmonized identification information
- Develop tag data standards
- Define passive and active RFID usage in close cooperation with regulation authorities
- Develop an agreed standard for data exchange between different parties while considering existing aviation standards such as ISO (International Standards Organization) standards

for RFID systems that cover identification cards and smart labels and ATA Spec 2000 for definition of data structure

## RFID and safety aspects

For RFID use on aircraft, the main requirement is that RFID devices need to be of high integrity and radio frequency stable.

National airworthiness authorities are working on the airworthiness approval and regulations policy for passive RFID to be used on board civil aircraft. The Federal Aviation Agency (FAA) issued a policy guidance memo for 13.56 MHz passive RFID on 13th April 2005.

Airbus expects the FAA memo to be followed by similar action from the European Aviation Safety Agency (EASA).

The main objectives of such a safety policy are that data of parts must be accessible any time, anywhere, by anyone and need to be in line with data protection rights.

Components need to be easily traceable with a full transparency of the product life cycle and the possibility of verifying information on line 24/7 from one central secure database.

## Safety in flight aboard commercial aircraft

In cooperation with a European charter airline, Airbus has performed in-flight tests of RFID tags carried on Airbus A320 aircraft. During over 6,000 documented flight hours in 12 aircraft, tests were conducted with zero defects. The tag received unlimited approval from the German Airworthiness Authorities (LBA) after this successful test, paving the way for future airworthiness approval of the technology.

## Safety for tag Resistance to physical impact

Together with EADS Astrium in Bremen, Airbus performed safety tests with RFID tags to identify any risk of defect or interference in the hostile environments common in commercial aircraft operation. Tags were exposed to severe conditions followed by read and write experiments. Safety tests included temperature changes, chemical liquid exposure, humidity, lightning induced transient susceptibility, electrostatic discharge, shock and vibration as well as fire impact. None of the physical impacts had negative effects on the read write functionality or data integrity. Neither did the hostile test environment cause defects in the tags. The tag is resistant against a temperature range from minus 50° Celsius to plus 70° Celsius, safe against aggressive liquids and safe from electromagnetic interference (EMI). Certification of conformity to RTCA DO-160 was received from EADS laboratory Astrium Bremen.

## Safety for data access

An important aspect is authorized password protection for data access and modification and also to back-up data on the ERP system.

## Safety for part security

The destruction of a tag needs to be ensured if removed from a part or tool. It is essential to prevent counterfeit parts equipped with tags from scrapped components. Each tag must have a valid serial number. Manufacturers can use the chip to prevent unapproved parts entering the supply chain.





## RFID/ERP integration at Airbus tools for loan service

In 1997 Airbus started to deploy RFID in its tools business. The motivation for this innovative step was the intention to provide a better, quicker service to customers by improving the efficiency of administration in the tool loan business. By introducing RFID, Airbus was able to reduce the Turn around Time (TAT) by over 25% and processes throughout the supply-chain were accelerated, among them for good data entries and quality inspection due to faster and more accurate data availability.

As a result, tools managed with RFID had a higher effective availability, in addition reduced paperwork and error rates led to significantly reduced administration.

Some of the other significant results included:

- Higher data accuracy due to automatic data capture and avoidance of carry forward and multiplying data entry mistakes
- Easier, faster and improved flow of information between all participants in the supply chain

- Faster loan tool re-availability due to streamlined process and thus reduced stock levels
- Possibility to completely trace the part's history from cradle to grave
- Faster and more accurate loan invoicing

### HOW IT WORKS

The Airbus supply chain management activities for tools are based on an ERP Supply Chain Event Manager (SCEM), which is the central system, functioning between the Airbus back office ERP system and the RFID infrastructure consisting of tag, RFID reader and middleware. The middleware is a software specifically developed for Airbus to ensure communication between the RFID reader and the SCEM. The SCEM is linked to the ERP system via an ERP application interface. Using an ERP exchange infrastructure, the management console communicates with the RFID middleware via an XML (eXtensible Markup Language) interface. The data is then written to or read from the tag via the RFID server. The interface is open to allow incorporation of bar code scanning or other SCEM or ERP standard interfaces at a later date. The SCEM triggers the process and workflows, both internally and externally.

### Complete paperwork available on RFID tags

- Last certificate
- Original receipt number
- Last check
- Original certificate
- Part number
- Tool set
- No. of units
- Periodic check code
- Serial number
- Designation
- Net / gross tare
- Dimensions - length, weight, height
- Owner
- Next check
- Test laboratory
- Manufacturer
- Original receipt date vendor
- Last receipt date
- Customs code
- Shipping information
- Shipping advice

### Benefits of RFID in the tool loan business

- Less (or no) paperwork
- Leaner administration
- Simple and accurate exchange of data
- Standardized documentation in compliance with aerospace industry standard ATA Spec 2000
- Instant availability of all the necessary data with the tool
- Repair order on the tag
- Improved repair management
- Availability of next shipping address

1 The cycle starts in the ERP system with a customer order, which triggers an event in the SCEM, starting the process. The ordered tool is then prepared for delivery to the customer.

2 The forwarder collects the tool shipment and updates the transportation data in the ERP system, resulting in a message that creates an event in the SCEM. The message is then passed via the middleware to the RFID reader and written on the shipments tag and tool box.

3 The data is now available electronically and online, both on the RFID tags and via the SCEM capability on the Internet and can be accessed by the authorized supply chain parties.

4 When the tool is delivered to the customer by the forwarder, the delivery is acknowledged through a mobile device via the Internet signalling the SCEM that the delivery is complete. The tool data and status is available in the SCEM and online at every stage in the process enabling efficient shipment tracking and routing between customers, repair shop and Airbus warehouses.

5 Once the customer returns the tool, the tag on the tool is read and the SCEM automatically notifies quality inspection by email, avoiding any delay in the internal process. After this a quality inspection and packing is carried out. Once this is notified, the tool is registered as quality inspected and ready for delivery again.

Processes possible today include the return of tools to the tool shop by customers, transfer of tools from warehouse to repair shop, and return of tools from repair shop to the warehouse.

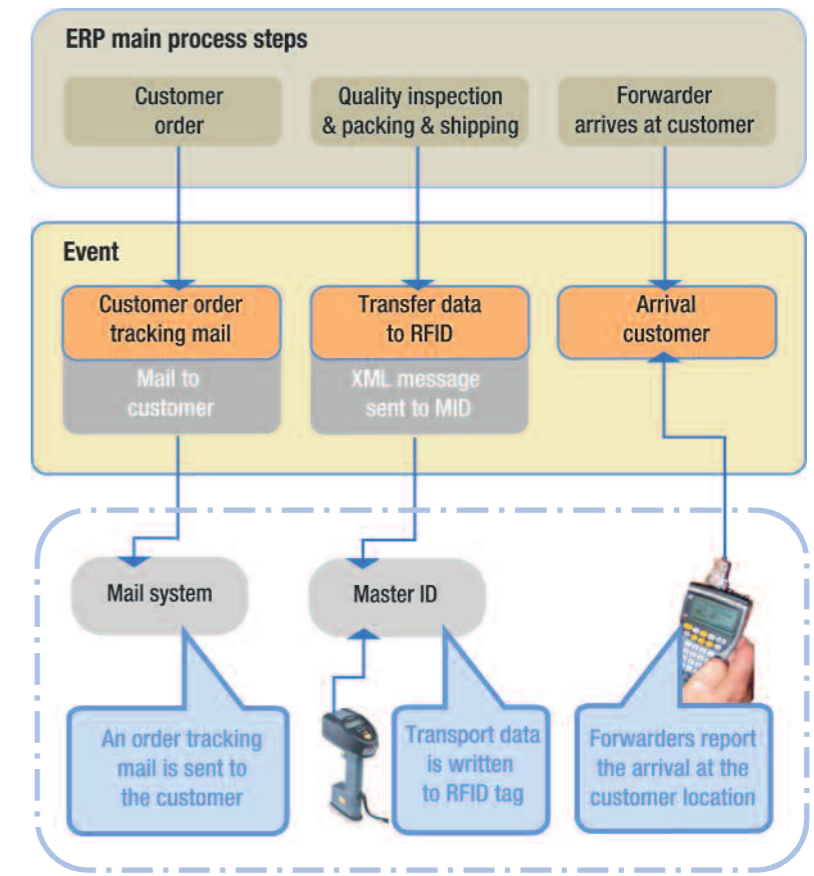

The instant availability of administrative data provides better transparency of the supply chain, thereby minimizing idle time and improving tool availability. The next step will be to integrate customers and freight carriers into the RFID processes. They will then be able to update the data on the chip and track the location of a particular tool using the SCEM via the Internet.

Airbus Loan Process ERP Supply chain event Management & RFID







# Customer support

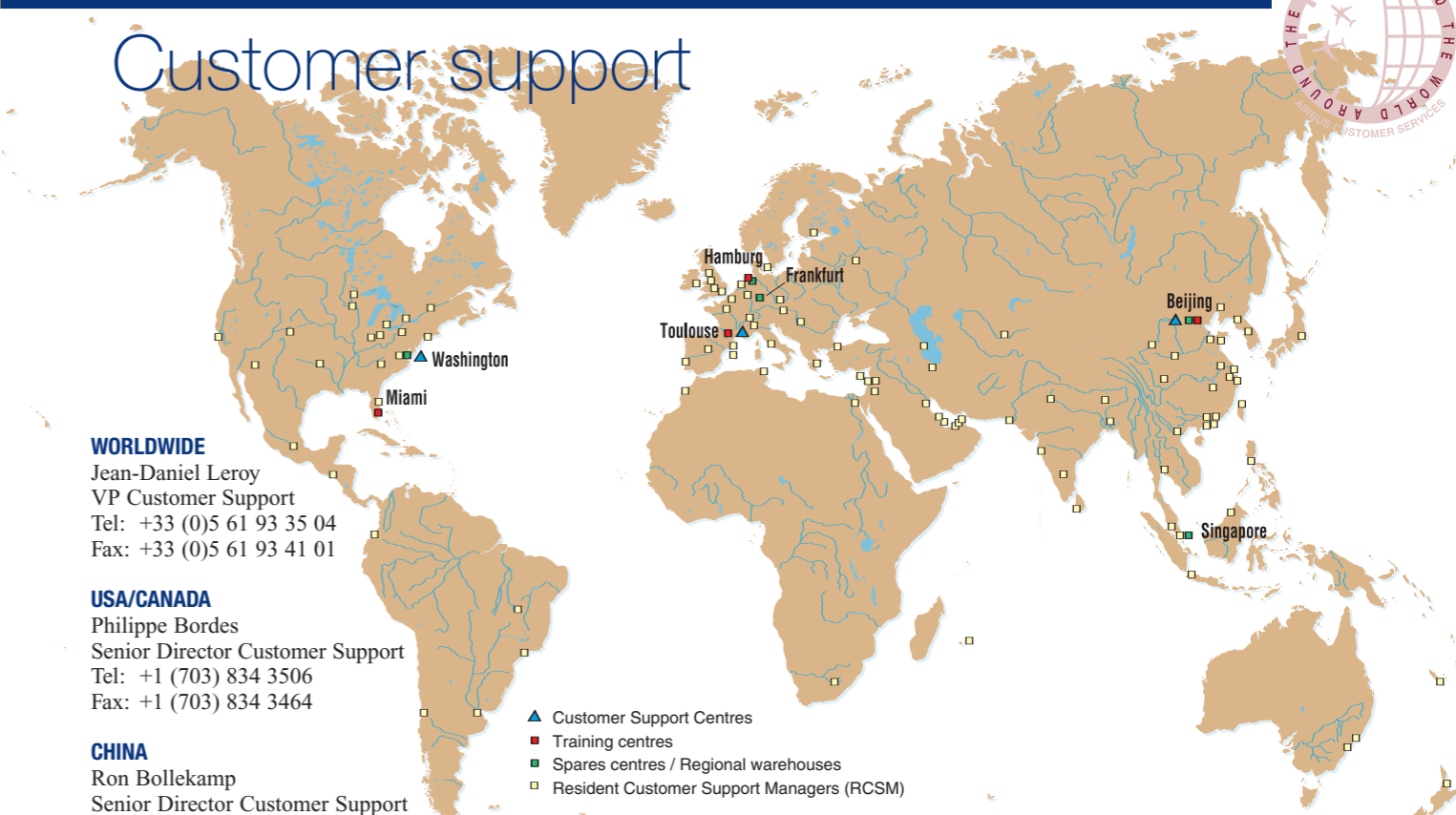

## Airbus promotion of RFID applications

Airbus is actively promoting RFID through various projects of the RFID application, for example in cargo and luggage handling and also facilitates knowledge transfer on these applications to customers through regular conferences. For this purpose, Airbus is creating a knowledge database for future customer access.

The most important next step is the revision of the ATA Spec 2000 and general agreement from the FAA and EASA.

Airbus has started several projects to further test RFID technology in the aerospace environment. The selection process for the solution providers has already started.

**CERTIFICATION OF RFID TAGS AS REPLACEMENT OF YELLOW TAGS**  
Airbus puts great emphasis on the elimination of paper documents for supplier parts. By application of RFID, the so-called Yellow Tags identifying the quality control status of a part will no longer be required.

**AIRBUS WAREHOUSE TO OPERATE FULLY WITH RFID**  
Airbus is evaluating the launch of a pilot project for an all RFID warehouse. Once a go-ahead decision has been taken, RFID can be introduced in three steps:

- Tools & ground support equipment will be equipped with RFID
- Repair management and quality inspection will be managed via RFID
- RFID will be extended to all spares stored in this warehouse

**UNAPPROVED PARTS IDENTIFICATION PROJECT.**  
Airbus has launched a project with a university to provide a means for the identification of unapproved parts in aircraft engines through RFID.

**RFID IN LOGISTICS FOR MANUFACTURING**  
Airbus has launched a project with a university to investigate and deploy the use of RFID in the logistics of manufacturing.

**CABIN INTERIOR PARTS**  
Airbus has launched a project to equip specific cabin interior parts with RFID to support catering requirements.

### CONTACT DETAILS

**Andreas Teufel**  
Airbus Customer Services  
Director Spares Marketing /On-site Support  
Spares Support and Services  
Tel: +49 (0) 40507 62320  
Fax: +49 (0) 40507 62155  
andreas.teufel@airbus.com  
http://spares.airbus.com

**Carlo K. Nizam**  
Airbus Customer Services  
Head of Business Systems Improvement  
Tel: +44 (0) 11793 64119  
Fax: +44 (0) 11793 65133  
carlo.nizam@airbus.com

**Jens Heitmann**  
Airbus Customer Services  
Head of Systems/Equipment Standardization  
Tel: +49 (0) 40743 75991  
Fax: +49 (0) 40743 77998  
jens.heitmann@airbus.com

### WORLDWIDE

Jean-Daniel Leroy  
VP Customer Support  
Tel: +33 (0)5 61 93 35 04  
Fax: +33 (0)5 61 93 41 01

### USA/CANADA

Philippe Bordes  
Senior Director Customer Support  
Tel: +1 (703) 834 3506  
Fax: +1 (703) 834 3464

### CHINA

Ron Bollekamp  
Senior Director Customer Support  
Tel: +86 10 804 86161  
Fax: +86 10 804 86162 / 63

### RESIDENT CUSTOMER SUPPORT ADMINISTRATION

Jean-Philippe Guillon  
Director  
Resident Customer Support Administration  
Tel: +33 (0)5 61 93 31 02  
Fax: +33 (0)5 61 93 49 64

### TECHNICAL, SPARES, TRAINING

Airbus has its main Spares centre in Hamburg, and regional warehouses in Frankfurt, Washington D.C., Beijing and Singapore.

Airbus operates 24 hours a day every day. AOG Technical and Spares calls.

Airbus Technical AOG Centre (AIRTAC)  
Tel: +33 (0)5 61 93 34 00  
Fax: +33 (0)5 61 93 35 00  
support.airtac@airbus.com

Spares AOGs in North America should be addressed to:  
Tel: +1 (703) 729 9000  
Fax: +1 (703) 729 4373

Spares AOGs outside North America should be addressed to:  
Tel: +49 (40) 50 76 3001/3002/3003  
Fax: +49 (40) 50 76 3011/3012/3013

Airbus Training Centre Toulouse, France  
Tel: +33 (0)5 61 93 33 33  
Fax: +33 (0)5 61 93 20 94

Airbus Training subsidiaries  
Miami, USA - Florida  
Tel: +1 (305) 871 36 55  
Fax: +1 (305) 871 46 49  
Beijing, China  
Tel: +86 10 80 48 63 40  
Fax: +86 10 80 48 65 76

- ▲ Customer Support Centres
- Training centres
- Spares centres / Regional warehouses
- Resident Customer Support Managers (RCSM)

#### RCSM location

RCSM location	Country
Abu Dhabi	United Arab Emirates
Algiers	Algeria
Al-Manamah	Bahrain
Amman	Jordan
Amsterdam	Netherlands
Athens	Greece
Auckland	New Zealand
Baku	Azerbaijan
Bandar Seri Begawan	Brunei
Bangalore	India
Bangkok	Thailand
Barcelona	Spain
Beirut	Lebanon
Brasilia	Brazil
Brussels	Belgium
Budapest	Hungary
Buenos Aires	Argentina
Cairo	Egypt
Casablanca	Morocco
Charlotte	United States of America
Chengdu	China
Colombo	Sri Lanka
Copenhagen	Denmark
Dalian	China
Damascus	Syria
Delhi	India
Denver	United States of America
Derby	United Kingdom
Detroit	United States of America
Dhaka	Bangladesh
Doha	Qatar
Dubai	United Arab Emirates
Dublin	Ireland
Duluth	United States of America
Dusseldorf	Germany
Fort Lauderdale	United States of America
Frankfurt	Germany
Guangzhou	China
Hangzhou	China
Hanoi	Vietnam
Helsinki	Finland
Hong Kong	S.A.R. China
Indianapolis	United States of America
Istanbul	Turkey
Jakarta	Indonesia
Jinan	China
Johannesburg	South Africa
Karachi	Pakistan
Kuala Lumpur	Malaysia
Kuwait city	Kuwait
Lanzhou	China
Larnaca	Cyprus
Lisbon	Portugal
London	United Kingdom

#### RCSM location

RCSM location	Country
Louisville	United States of America
Luton	United Kingdom
Macau	S.A.R. China
Madrid	Spain
Manchester	United Kingdom
Manila	Philippines
Mauritius	Mauritius
Memphis	United States of America
Mexico City	Mexico
Miami	United States of America
Milan	Italy
Minneapolis	United States of America
Montreal	Canada
Moscow	Russia
Mumbai	India
Nanchang	China
Nanjing	China
New York	United States of America
Newcastle	Australia
Ningbo	China
Noumea	New Caledonia
Palma de Mallorca	Spain
Paris	France
Paro	Bhutan
Phoenix	United States of America
Pittsburgh	United States of America
Prague	Czech Republic
Qingdao	China
Quito	Ecuador
Rome	Italy
Sana'a	Yemen
San Francisco	United States of America
San Salvador	El Salvador
Santiago	Chile
Sao Paulo	Brazil
Seoul	South Korea
Shanghai	China
Sharjah	United Arab Emirates
Shenyang	China
Shenzhen	China
Singapore	Singapore
Sydney	Australia
Taipei	Taiwan
Tashkent	Uzbekistan
Tehran	Iran
Tokyo	Japan
Toronto	Canada
Tulsa	United States of America
Tunis	Tunisia
Vienna	Austria
Washington	United States of America
Xi'an	China
Zurich	Switzerland



## Conclusion

RFID implementation in the tools loan service has resulted in significant improvements in service to customers and reductions in administration. There are multiple continuing qualitative advantages contributing further to efficiency and administrative reductions. The next steps will be to enable freight carriers to manage the physical processes of the tool loan service by themselves.

A future step will be to use RFID technology to manage certain groups of aircraft spares.

Airbus will continue heading industry activities to define and implement industry standards.



# A double-decker of fifty years ago...

The first flight of the A380 in April 2005 generated unprecedented worldwide publicity and caught the attention of the general public concerning large double-deck aircraft.

However, the A380 is not the first double-deck aircraft, there have been a number of them over the years, one of which was the Breguet 763 airliner.

Design work on this aircraft started in 1936 with the Breguet 730 prototype, but was postponed due to the Second World War. In 1946, work started again and the prototype, designated Breguet 761, made its first flight at Villacoublay in France on 15 February 1949.

A heavier version was then introduced, designated the 763 Provence, which was destined for Air France and flew mainly on the route from Paris to Algiers from 1953 to 1971.

A final version of the aircraft, the 765 Sahara, was built for the French Air Force and flew for the first time in July 1958. This version was heavier, modified for military use and had longer range. It remained in service until 1969 when the Transall replaced it.

In its day, it was an impressive aircraft, but a comparison of its characteristics with the state-of-the-art A380 shows just how far the aviation industry has come in the fifty-six years since this double-decker first flew.

*The Breguet 765 characteristics were:*  
Wingspan: 45.5m (149ft)  
Length: 29m (95ft)  
Height: 10.15m (33ft)  
Speed: 400km/h (250 miles/hour)  
Range: 4000km (2,500 miles)  
Payload: 17t freight or 130 passengers  
Flight crew: 5

Photo "Collection Musée Air France" By courtesy of Air France.





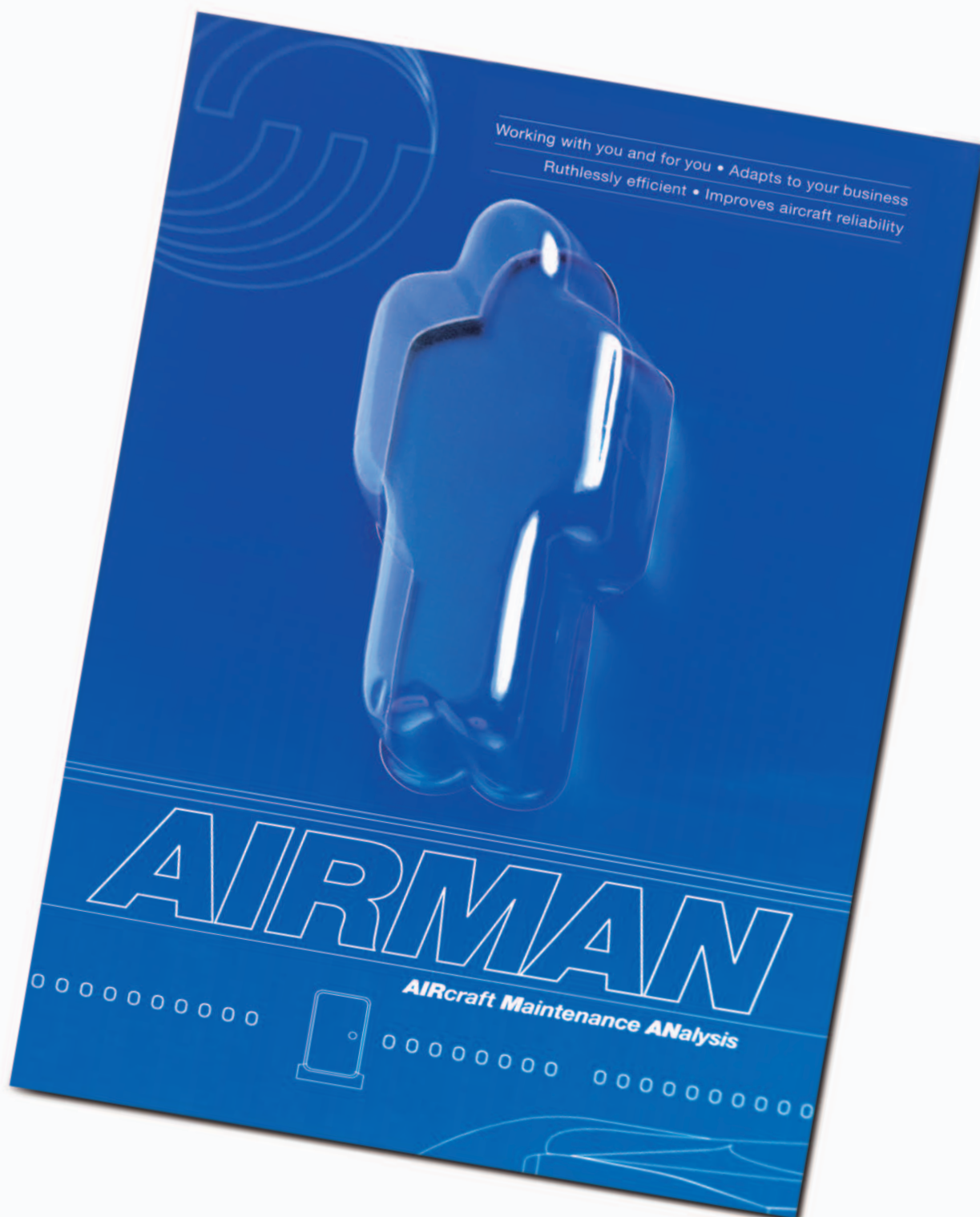

## AIRMAN AIRcraft Maintenance ANalysis.

He's flexible and adaptable. He can't leap tall buildings in a single bound but he can run a fleet of aircraft. He's AIRMAN: A unique software tool designed to optimise the maintenance of your fleet. Always handy to have around, AIRMAN can reduce aircraft turnaround time. He can provide millions

of in-service live data checks. He can provide analysis of available data and access to all relevant information He can save millions. For more contact Airbus Customer Services **Airbus. Setting the standards**



**AIRBUS**