

JANUARY 2013  
FLIGHT  
AIRWORTHINESS  
SUPPORT  
TECHNOLOGY

# FAST<sup>51</sup>

A I R B U S T E C H N I C A L M A G A Z I N E

F A S T 5 1



# Customer Services events

## Just happened

### Airbus Lessors Conference

The 9<sup>th</sup> Lessors Conference took place in October in the United States with over 140 participants from 90 leasing companies. The lessors appreciated the initiative of the presentations to promote an interactive approach with the audience and an exchange with Airbus' Customer Services & Support senior management team.

Many important technical subjects have been raised with a focus on Upgrade Services. Fleet performance, new regulations, requirements, safety enhancements and solutions, including the Sharklet retrofit presentations have been shown.

In addition to services for lessors and improvements in the efficiency of aircraft transitions, a new service was presented which is part of an EASA process when required to import/export an aircraft to/from the European Union.

### Airbus Material, Logistics, Suppliers and Warranty symposium

The overwhelmingly positive feedback that Airbus received for this year's symposium in Bangkok (Thailand) has once again proven that 'Material Matters!'. This event gathered 109 customers and 22 suppliers who received an update on the latest developments and initiatives that were taken. Interactive discussions in various workshops and caucus sessions facilitated the right frame to commonly develop solutions and get prepared for the anticipated market growth. Airbus has listened carefully to the customers' requirements, is evaluating them and will take actions accordingly with the aim of presenting the results at the next symposium.

Detailed information is available on the dedicated e-site on the AirbusWorld homepage (in the "What's new" box).

### A successful Structure seminar

Early November in Toulouse (France), over 116 worldwide representatives from airlines, lessors and MRO organisations participated to this seminar, creating a unique opportunity for the structure community to share relevant subjects and gather the overall experience, knowledge and support necessary to empower the motto: "Structure Support: A joint effort".

Airbus structure specialists provided technical presentations, including maintenance programme topics and in-service fleet issues. Demonstrations were provided on IDOLS, Repair Manager,

Structure Trainings and new Consumable Material Lists (CML). A dedicated NDT (Non-Destructive Testing) workshop allowed the participants to practice on Pulse Thermography and Ultrasonic Phased Array methods.

### Technical Data Support & Services symposium

An impressive participation of more than 160 attendees from operators, suppliers and MROs attended this sixth Technical Data symposium held in Istanbul (Turkey).

"Supporting your Digital Operations!" was this edition's motto covering solutions for technical data in the fields of Maintenance & Repair, Spares & Suppliers, Scheduled Maintenance, Service Bulletins and Flight Operations. More than 30 presentations, demos and workshops were delivered by Airbus and some additional subjects were kindly presented by guest speakers from Qatar Airways, TAP Maintenance & Engineering and Zodiac Aerospace. After an interesting caucus, the attendees highlighted the exceptional networking opportunity in such events and delivered strong encouragements to keep up the good work in the future!

## Coming soon

### Material Management seminars 2013

Cost reduction and increased operational efficiency are permanent objectives in today's challenging times. In order to respond, Airbus has scheduled 11 seminars in 2013 with different levels of specialization in different locations around the world, specifically developed to support more efficient material management. The training portfolio has been extended by including now a "Tools and GSE seminar". Airbus also offers on-site courses fully tailored to suit the customers' needs.

For further details, please contact: [spares.training@airbus.com](mailto:spares.training@airbus.com) or see the detailed schedule with dates and locations on the AirbusWorld Material Management community homepage.

### Airbus 2013 events' agenda

At the time of FAST magazine going to press, the 2013 event agenda is being organized and major Airbus events such as the A380 symposium or the Airbus 11<sup>th</sup> Training symposium are taking place, both events in Dubai (United Arab Emirates).

In the next edition, we will provide you with the outcome of these events and the fixed dates of the upcoming events.



# FAST

M A G A Z I N E  
A I R B U S

FLIGHT  
AIRWORTHINESS  
SUPPORT  
TECHNOLOGY

Publisher: Bruno PIQUET  
Editor: Lucas BLUMENFELD

Page layout: quatcoul

Cover: Sharklet retrofit  
Photo by: Philippe MASCLLET

Authorisation for reprint of FAST Magazine articles should be requested from the editor at the FAST Magazine e-mail address given below

Customer Services Communications  
Tel: +33 (0)5 61 93 43 88  
Fax: +33 (0)5 61 93 47 73  
e-mail: fast.magazine@airbus.com  
Printer: Amadio

FAST Magazine may be read on Internet  
<http://www.airbus.com/support/publications>  
under 'Quick references'  
ISSN 1293-5476

© AIRBUS S.A.S. 2012. AN EADS COMPANY  
All rights reserved. Proprietary document

By taking delivery of this Magazine (hereafter "Magazine"), you accept on behalf of your company to comply with the following. No other property rights are granted by the delivery of this Magazine than the right to read it, for the sole purpose of information. This Magazine, its content, illustrations and photos shall not be modified nor reproduced without prior written consent of Airbus S.A.S. This Magazine and the materials it contains shall not, in whole or in part, be sold, rented, or licensed to any third party subject to payment or not. This Magazine may contain market-sensitive or other information that is correct at the time of going to press. This information involves a number of factors which could change over time, affecting the true public representation. Airbus assumes no obligation to update any information contained in this document or with respect to the information described herein. The statements made herein do not constitute an offer or form part of any contract. They are based on Airbus information and are expressed in good faith but no warranty or representation is given as to their accuracy. When additional information is required, Airbus S.A.S. can be contacted to provide further details. Airbus S.A.S. shall assume no liability for any damage in connection with the use of this Magazine and the materials it contains, even if Airbus S.A.S. has been advised of the likelihood of such damages. This licence is governed by French law and exclusive jurisdiction is given to the courts and tribunals of Toulouse (France) without prejudice to the right of Airbus to bring proceedings for infringement of copyright or any other intellectual property right in any other court of competent jurisdiction.

Airbus, its logo, A300, A310, A318, A319, A320, A321, A330, A340, A350, A380 and A400M are registered trademarks.

Photo copyright Airbus  
Photo credits:

Airbus Photographic Library, Airbus Flight Test Photo Lab, EADS Corporate Heritage, E<sub>x</sub>M Company, Eurocontrol.

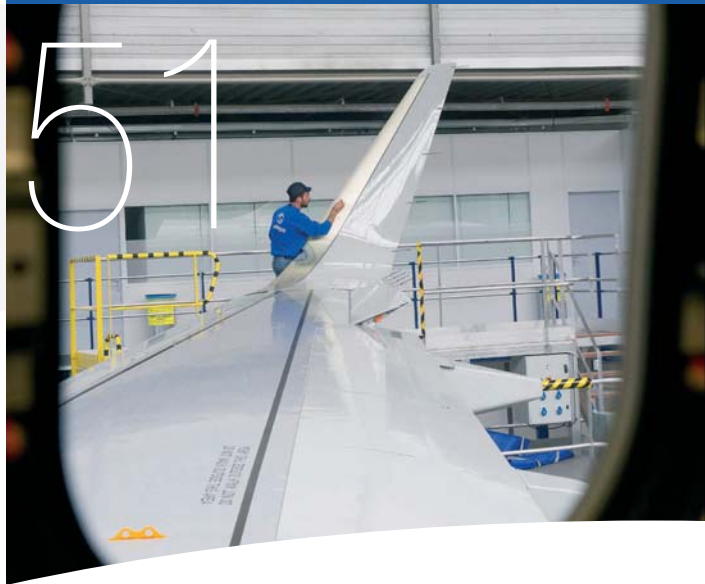

## Customer Services

### Events

#### eTaxi

Taxiing aircraft with engines stopped  
Yann NICOLAS

#### A320 Family Sharklet retrofit

Hunting down fuel burn  
Simon GALPIN  
François HUGO

#### Widespread Fatigue Damage

A300B: Compliance to the ageing aircraft regulation  
Nicolas TURREL  
Didier AURICHE

#### Optimized spare parts investment

Initial Provisioning influencing A350 XWB development  
Stefan TRINKER  
Daniel SCHWARZER

#### Managing aircraft security

A new challenge for the air transportation community  
Pascal ANDREI  
Gernot LADSTAETTER  
Isabelle DUFEU

#### Airport taxiing

A new era relieving animals

#### Customer Services Worldwide

Around the clock... Around the world

2

11

17

24

29

36

37



This issue of FAST Magazine has been printed on paper produced without using chlorine, to reduce waste and help conserve natural resources.

**Every little helps!**



# eTaxi Taxiing aircraft with engines stopped

The idea to taxi aircraft without the main engine thrust is not recent. When Aerospatiale's (one of Airbus' founder partners) design office provided its conclusions on a study for "motorised wheels for autonomous taxiing for a 76 tonnes subsonic aircraft" back in 1977 (figure 1), the technology and oil prices were not at today's high level, making this idea a "must" to offer. As part of Airbus' commitment to continuously improve

its products and develop environmental-friendly solutions, Airbus' Research and Technology programme has revisited this case with various solutions in the recent years. Today's improved technologies considering more electrical equipment power over the equipment mass ratio, higher reliability figures and fuel prices together with a longer taxi time, are making an onboard solution for autonomous taxiing more and more attractive.



**Yann NICOLAS**  
Research and Technology  
Programme Leader  
Aircraft Control  
Airbus S.A.S.

## eTaxi for which aircraft?

Aircraft taxiing is today performed through the use of engine thrust. On twin-engine aircraft, one or the two engines are used while taxiing, depending on the operator's policy and operational conditions.

The eTaxi system offers:

- Taxi-out and taxi-in with all engines stopped capability,
- A total aircraft autonomy allowing the aircraft to "pushback" without any tractor.

The eTaxi system is an onboard solution. This means that there is some significant hardware to be installed on the aircraft, consequently some weight to be added.

This explains why such a technology is only considered for short and medium range aircraft, and not for long haul flights in which the aircraft would burn the fuel saved on ground, in flight.

So it is intended to propose eTaxi as an option available for the A320 Family fleet, only.

Airbus is working with the objective to propose both forward fit and retrofit.

**Motorized wheels' principle designed by Aerospatiale in 1977**

Figure 1

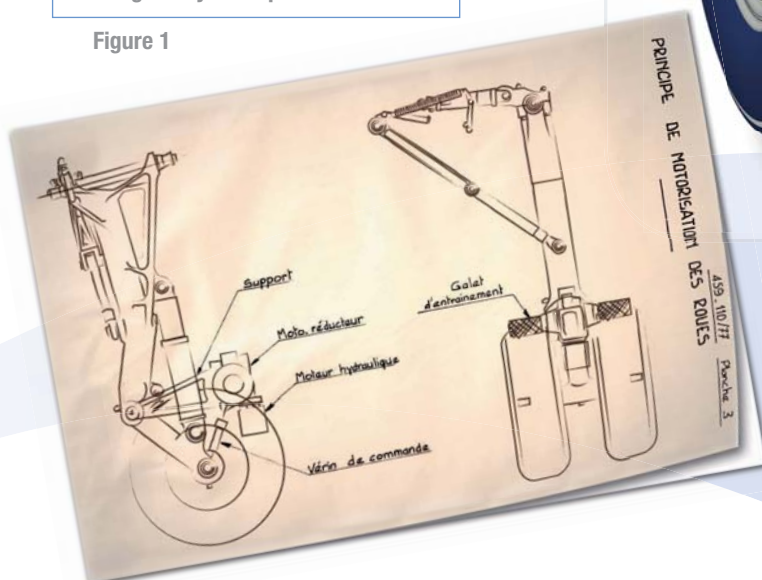

## eTaxi system and TaxiBot

While eTaxi is an on-board solution, TaxiBot is a product that enables aircraft taxiing with engines stopped and APU running, using a diesel-electric tractor controlled by the aircraft's pilot through his regular controls (tiller and brake pedals).

When taxi-out is completed, TaxiBot is disconnected from the aircraft Nose Landing Gear by the TaxiBot driver, who then drives back the vehicle to the apron. Unlike eTaxi which is specific to A320, this concept of tow-bar-less towing aims at the capability to tow all types of aircraft with more than

100 seats (both Airbus and non-Airbus types).

It will target a deployment on the major airports where such concept makes sense.

There will be two TaxiBot variants: One for single-aisle aircraft (Narrow-Body TaxiBot) and the other for twin-aisle types (Wide-Body TaxiBot).

The first prototype is currently in test phase at Châteauroux (France), with an operational test under real conditions to be conducted at Frankfurt am Main Airport (Germany) in spring 2013.

**eTaxi electric motor and transmission installation on Main Landing Gear**

Figure 2

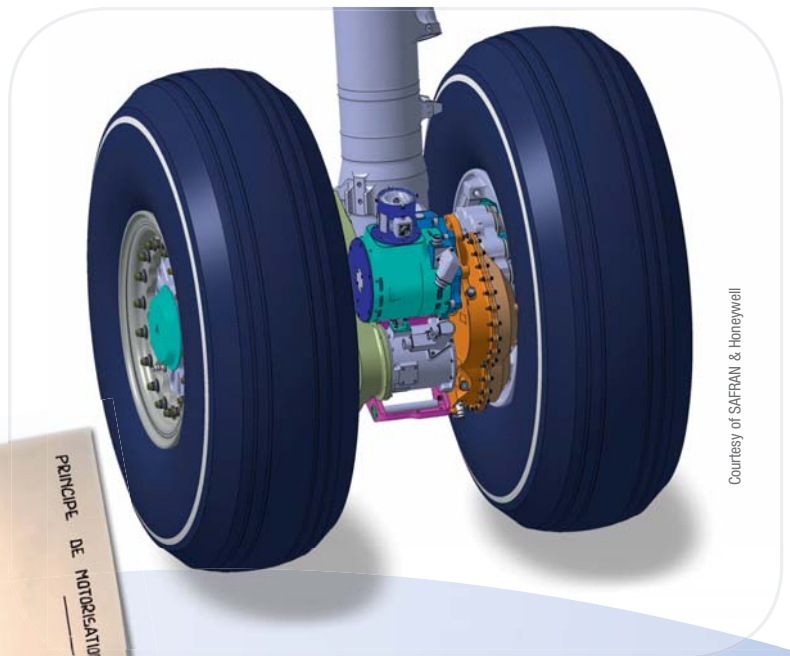

Courtesy of SAFRAN & Honeywell

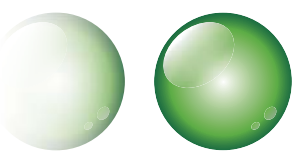

### On-going testing

**Airbus testing:**

Airbus is using the APTV (Accelerated Pavement Testing Vehicle) so-called the “Turtle” (figures 3 & 4), in an A320 configuration, to measure key sizing parameters. Amongst them, the simulation of the “breakaway” forces needed to move the aircraft with almost “square tyres”, to test the phenomenon after a long stop. This “Turtle” vehicle has been used for the HTPT (High Tyre Pressure Testing - read FAST 48 magazine) but the Main Landing Gear beams have been displaced and the weight adjusted to correspond to

the Landing Gear configuration, to MTOW, and centre of gravity of an A320. The “MOSART” (Modular Simulator for Airbus Research Tests) simulator is used by flight test pilots to evaluate the most appropriate eTaxi control device. More than five different manoeuvrability concepts (HMI – Human Machine Interface) have already been tested.

**Partners’ testing:**

Major partners have already pre-evaluated some concepts. They are now assembling prototypes for full scale testing.

## eTaxi system performances and architecture

Whereas eTaxi system performances and characteristics are still under construction and refinement, some key design objectives are emerging.

### TAXI-OUT AND TAXI-IN OPERATIONS

Studies have been conducted to propose the best operational compromise between the eTaxi performance (speed, acceleration, aircraft weight, external conditions, etc.) and the sizing (hence additional hardware weight onboard).

Airbus is aiming to achieve a performance requirement for taxi speed of 20kts (knots).

This speed is fully compatible with airport ground traffic and does not impact taxi time, whether the aircraft will be equipped, or not, with the eTaxi system. This has been confirmed after having conducted ground traffic simulations in several major airports.

The Turtle

Figure 3



An acceleration capability of 0 to 20kts in 90 seconds is considered as fully sufficient from an operational view point, as well.

#### REARWARD (“PUSHBACK”) OPERATION:

The rearward operation is a key feature offered by the eTaxi system. The pilot controls the backup of the aircraft from the cockpit thanks to an onboard device, at a maximum speed of 3kts.

#### ETAXI SYSTEM ARCHITECTURE

The eTaxi system includes electrical motors and their associated power electronics, electrical power protections, wires, cockpit control devices and control laws.

Large air cooled electric motors are integrated in between the Main Landing Gear wheels.

These electric motors are sized to provide the required torque to move the aircraft (breakaway force due to “square tyre effect” as simulated in figure 4) and to insure the required acceleration and taxi cruise speed in most conditions (taxiway slope, adverse wind, etc.).

The choice of the Main Landing Gear versus the Nose Landing Gear is to allow the eTaxi operations in all usual operational cases (i.e.: On wet taxiways, at MTOW (Maximum Take-Off Weight) and at the rear centre of gravity location). A Nose Landing Gear solution would provide a limited traction capability due to a weaker vertical load on this gear.

The power electronics which supplies and controls the electric motors is air cooled and installed close to the Main Landing Gear bay, requiring no cargo space.

The eTaxi system is fully controlled from the cockpit. Additional control means, indications and warnings are added for the pilot’s control and awareness, during the eTaxi phase.

The eTaxi control laws shall be integrated in the aircraft avionics. Various solutions are investigated (e.g.: Dedicated control unit or eTaxi control software can be hosted into the existing computer, such as the Braking and Steering Control Unit - BSCU).



#### definition

**Power electronics** is the application of solid-state electronics for the control and conversion of electrical power in order to drive the electric motor at a variable rotational speed. Hence, power electronics converts electrical power (at frequency and voltage levels) from aircraft electrical network to the electric motors.

Test installation for torque measurement on the Turtle

Figure 4



## Where does the electric power come from?

The technical and commercial electrical needs are still ensured and the bleed power is still available for the Environmental Control System (ECS). Several operational options and design solutions can be considered:

### Base eTaxi solution

Keeping today's APU, both engines stopped but accepting reduced performance. Using the existing APU (Auxiliary Power Unit) with its actual generator of 90kVA (kilo Volt Ampere) is the favourite and simplest solution to go for a minimum change.

However, the taxi performance with both engines stopped cannot be the nominal one in all conditions. While acceptable on many airports, it may not be sufficient at large airports with long taxiways as there is not enough electric power to supply both, the normal electrical loads and the eTaxi system for a full performance. As an example, an A320 at MTOW (Maximum Take-Off Weight) of 78 tonnes would only reach a maximum speed of 12kts. The performance is, of course, better for a lighter aircraft of 69 tonnes at 13.5kts.

### Hybrid eTaxi solution

Keeping today's APU, one engine at idle benefitting from a full performance. By still keeping the existing APU and APU generator ON, one engine can be kept at idle during the eTaxi operation.

Usual flight operations versus eTaxi

Figure 5

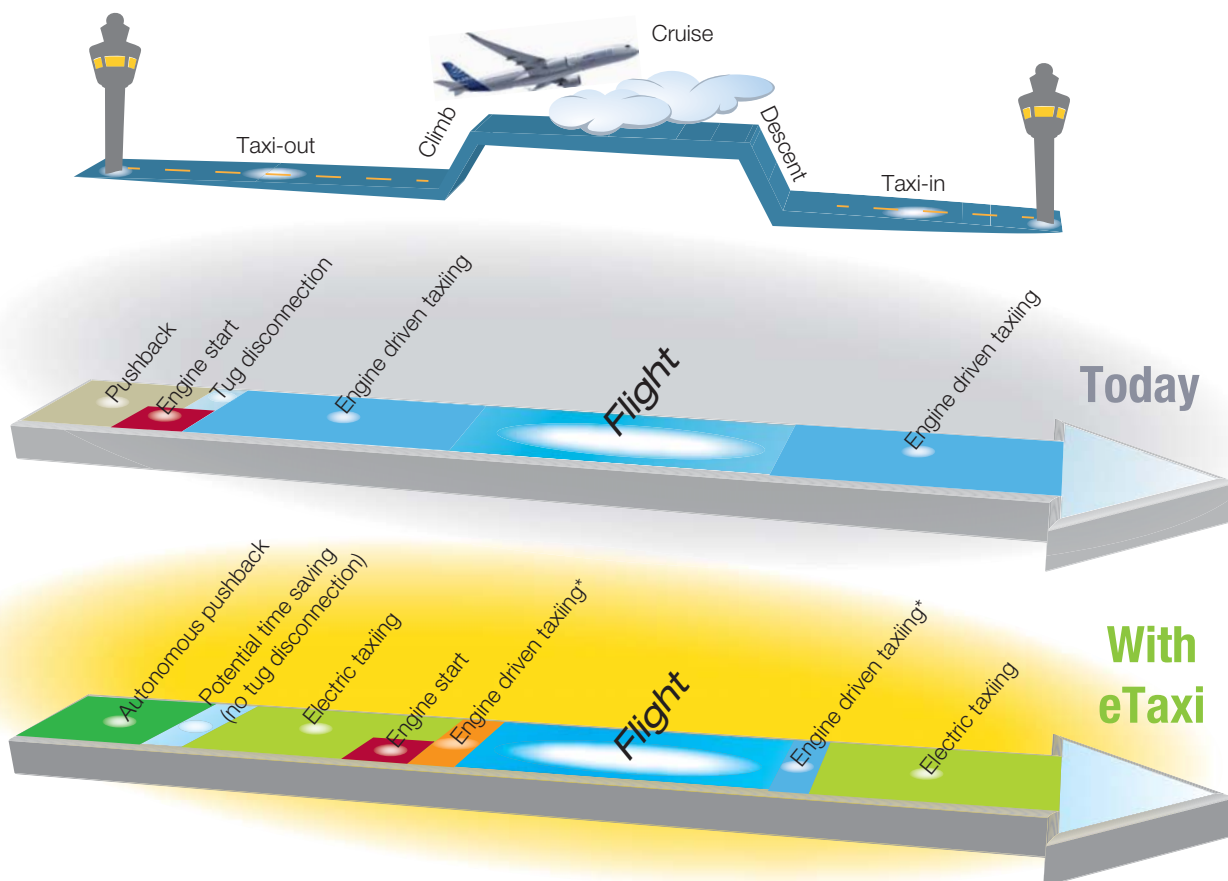

(\*) Engine warm-up and cool-down phases



This solution offers all the required electric power for a full performance (20kts on A320 at MTOW) as the engine IDG (Integrated Drive Generator) and APU generator are used together to supply the aircraft normal loads and eTaxi system. Nevertheless, there is still a significant fuel saving with this solution (even compared to usual single engine taxiing) due to the engine thrust of the aircraft not being used to accelerate - the acceleration being taken in charge by the eTaxi system. Obviously, there is still the full benefit of the “autonomous pushback” done with both engines stopped and with the APU only.

**Full eTaxi solution**

Modified APU with a new APU generator. The only way to get a full eTaxi performance with all engines stopped in every conditions (notably taking in consideration the aircraft weight) is to increase the APU generator

sizing and in consequence, to adapt the APU. Trade-off studies are still on-going by Airbus for an APU modification, aiming to increase, or not, its available electric power.

**eTaxi operation**

**NO TUG TO WAIT FOR PUSHBACK**

By switching the eTaxi push-button ON with the APU running, the pilot activates eTaxi and configures various other systems.

The Yellow hydraulic circuit (figure 6) Electrical Motor Pump (EMP) which is electrically supplied by the APU generator, provides the required hydraulic power for the nose wheel steering and for alternate braking (the Power Transfer Unit is turned off).

Then, the pilot is ready to backup the aircraft guided by one or two marshallers.

**d** definition

**Aircraft marshalling** is the signaling and communication between the ground handling personnel and pilots. The usual equipment of a marshaller is a reflecting safety vest, a helmet with acoustic earmuffs, gloves or marshalling wands and handheld illuminated beacons.

**Three independent hydraulic circuits on the A320 Family**

Figure 6

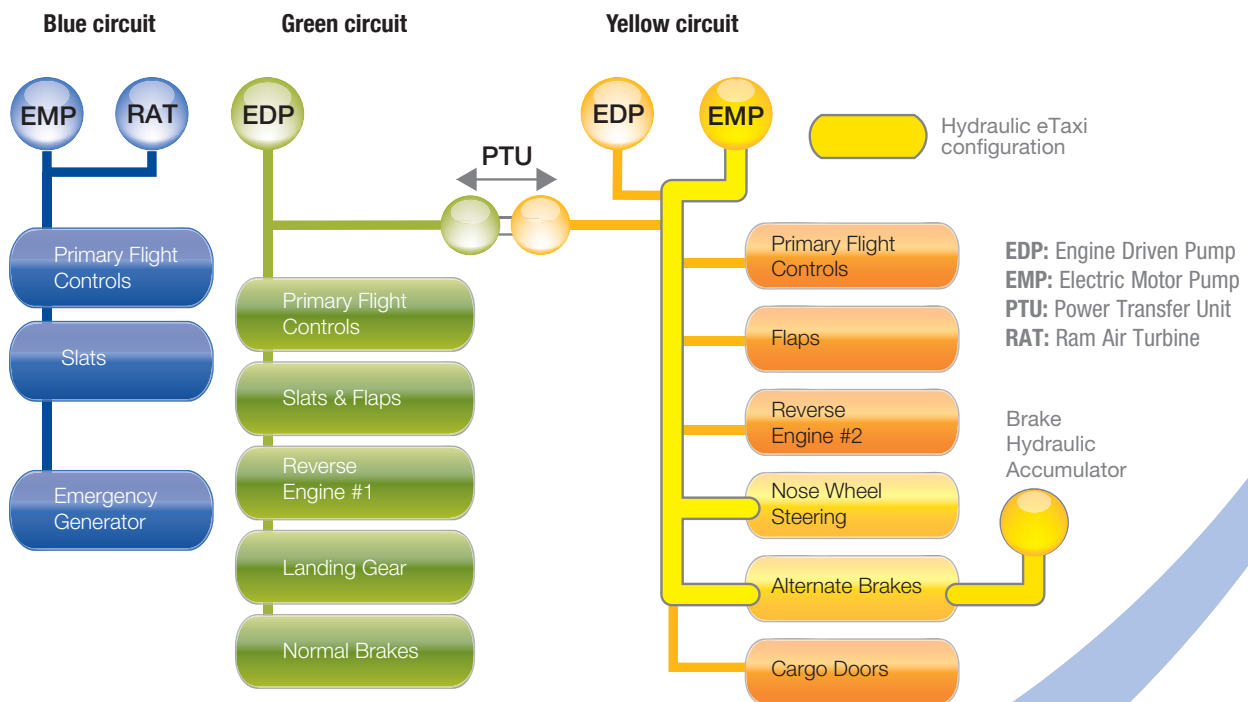

These three circuits supply several systems such as flight controls, high-lift, landing gear extension/retraction, braking, etc. The Green circuit supplies the normal braking system while the Yellow circuit supplies the alternate braking and nose wheel steering. Yellow alternate braking is backed-up by the brake hydraulic accumulator, in case of Yellow hydraulic system failure.

Note: The nose wheel steering has been powered by the Yellow hydraulic circuit system since the MSN 1939.

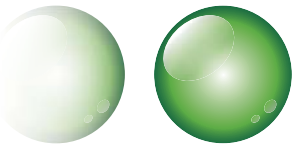

### Average taxi time from Airbus study

A320 Family in-service statistics  
12 months fleet average  
(April 2012)

- Average flight duration: 1.8 Flight Hours (FH)
- Average daily utilisation: 8.9 FH/day
- Average taxi time: 20 minutes (0.3 FH/flight)

In average, an A320 spends more than 15% of its time taxiing.

### TAXI-OUT

When the backup operation is completed, the pilot may immediately proceed to the eTaxi forward phase without waiting for the tractor's disconnection.

The pilot uses the eTaxi control device from the cockpit to accelerate and the usual brake pedals to slow down or stop the aircraft. It also allows switching off the electric motor power supply to gently decelerate the aircraft without using any brakes at all.

As the engines must be started 4 to 5 minutes prior to take-off for warm-up, the eTaxi system is designed to allow the engine start-up while eTaxiing the aircraft. The eTaxi system automatically disengages when both engines are ON or above 20kts.

Remark: In case of Hybrid eTaxi (i.e. With one engine at idle), the aircraft operation will be very similar to the existing single engine taxi operations.

The main difference is that acceleration control is done only by using the eTaxi control device in one case, and by using the engine thrust control lever in the other case.

### TAXI-IN

The engines are switched-off after landing, the pilot exits the runway, the APU is started and the eTaxi mode is switched ON. There is no need to stop the aircraft to engage the eTaxi mode.

Depending on whether the high thrust has been applied or not during the reverse thrust, it may be required to wait approximately three minutes to let the engines cool down before switching them off.

Finally, the aircraft is electrically driven up to the gate, with no need for tug, which may be mandatory when local restrictions prohibit the engine use close to the apron.

## eTaxi reduces fuel burn

Taxiing and queuing penalize the optimisation of an aircraft's performance. A short and medium range aircraft may spend from 10 to 30% of its time on taxiways (statistics based on 35 major European airports, absorbing 50% of European departures). Consequently, aircraft of these ranges burn up to 10% of their fuel on ground.

Fuel burn reduction on ground depends on several parameters such as:

- Reference scenario (today's operation): One or two engines taxi-out/taxi-in,
- Taxi-out and taxi-in duration,
- Taxiing: Number of stops and starts.



Estimated fuel savings with eTaxi

Figure 7

Block fuel = Trip fuel + Taxi fuel

**Trip fuel**

The eTaxi system adds some weight; however the impact on block fuel is limited.  
On a 500 NM flight, +400kg\* represents an additional 16kg fuel burn.

\* Weight non-contractual

**Taxi fuel**

Configuration	Fuel Burn Rate
<b>Today</b>	
2 engines taxi	12.5 kg/min
Single engine taxi + APU	9.5 kg/min
<b>eTaxi</b>	
Hybrid eTaxi (one engine at idle + APU)	7 kg/min
Full eTaxi (APU only)	2 kg/min

**Block fuel**

**Block fuel saving**

Case of Full eTaxi versus single engine taxi

$$\text{Fuel saving} = 16 \text{ kg} - (9.5 \text{ kg/min} - 2 \text{ kg/min}) \times (20 \text{ min} - (5 \text{ min} + 3 \text{ min})) = -74 \text{ kg}$$

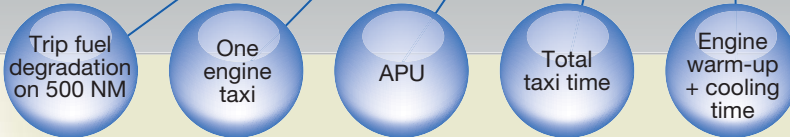

Remark: Tractor disconnection saving time not included.

Full eTaxi	versus	two engines taxi	-110 kg
Full eTaxi	versus	single engine taxi	-74 kg
Hybrid eTaxi	versus	two engines taxi	-50 kg
Hybrid eTaxi	versus	single engine taxi	-14 kg

Example of A320 with CFM56-5B4/3 (similar results with IAE):

- 500 NM (Nautical Mile) flight
- 20 minutes for taxi-out plus taxi-in
- 5 minutes considered for engine warm-up and 3 minutes for engine cooling

Hybrid eTaxi offers about 1.5% fuel burn reduction\* for typical A320 sector and taxi time

Full eTaxi offers about 3% fuel burn reduction\* for typical A320 sector and taxi time

\* versus 2 engines taxi

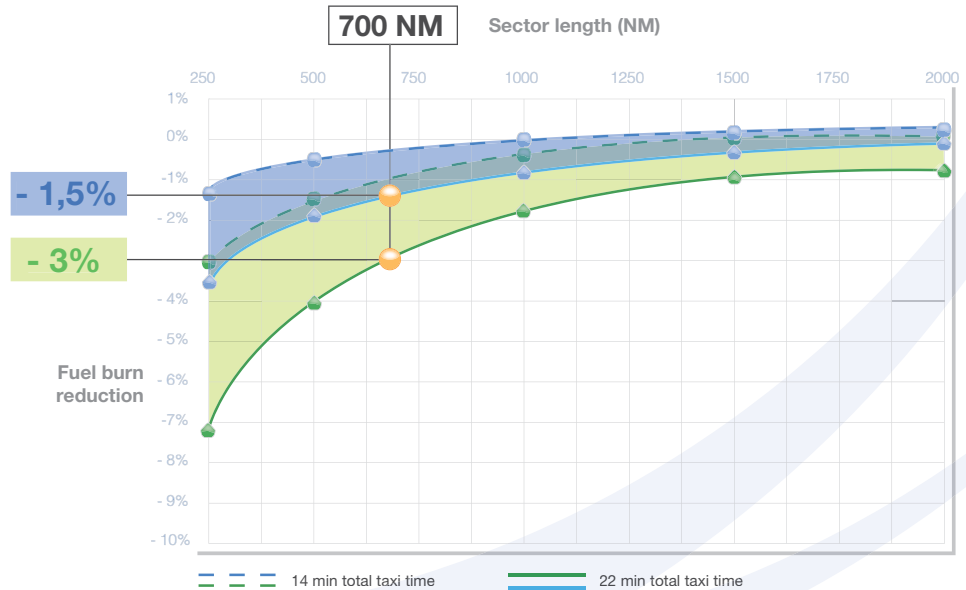

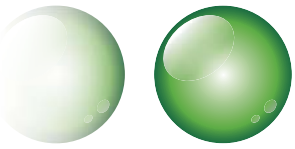

## Expected eTaxi benefits

By allowing the taxi with the main engines stopped, the eTaxi solution brings a direct fuel burn reduction and:

- A major reduction in ground emissions (CO<sub>x</sub> and NO<sub>x</sub>),
- Noise reduction on ramp with obvious benefits for ground staff,
- More autonomy versus airport infrastructures (no waiting for tug, no tug to pay for),
- Overall flight time savings by eliminating time disconnecting the tug after pushback,
- Less use of wheel brakes during taxi as there is no engine residual thrust, leading to potential brake wear reduction,
- Less risk of engine ingestion of damaging debris (Foreign Object Damage - FOD) and no engine jet blast blowing close to the gate,
- Improved safety for ground staff,
- High precision manoeuvring (no engine spool-up lag and inertia).

Evidently, the use of eTaxi does not impair aircraft operation capabilities and passenger comfort.



### CONTACT DETAILS

**Yann NICOLAS**  
 Research and Technology  
 Programme Leader  
 Aircraft Control  
 Airbus S.A.S.  
 Tel: +33 (0)5 61 93 68 20

## Conclusion

The eTaxi (electric taxiing) system is a very promising system that provides aircraft autonomy, reducing the use of engines during the taxi operations. It leads to substantial fuel savings while reducing emissions.

Airbus is actually investigating, in close collaboration with several industrial partners, different architectures and technologies for the best possible integration at aircraft level. A fully mature solution which preserves the recognized A320 Family Operational Reliability (OR) is targeted. Airbus is using all its available development, tests and certification resources to converge toward the most optimized solution.

eTaxi must be easy to install, remove, operate, and also easy to maintain.

In the long term, another generation of eTaxi will likely emerge with the next generation of short-medium range aircraft. As an example, we already know that eTaxi may offer many additional functionalities and benefits, when fully integrated in the aircraft design from the beginning. This is especially true when we consider the more electrical aircraft architectures which are being studied by Airbus, targeting a more efficient aircraft. The "More Electrical Aircraft", or even in the future the "All Electrical Aircraft" concepts, are aiming to make the electrical power the main or sole source of on-board power for flight controls, high-lift, the Environmental Control System, wing anti-ice, etc. This would allow the hydraulic and bleed systems' deletion.



# A320 Family Sharklet retrofit Hunting down fuel burn

With the evolution of fuel prices in the last years and the pressure to limit the environmental impact of aviation, reducing fuel burn has become a matter of great importance for airlines.

To meet this challenge, Airbus decided in 2009 to offer A320 Family customers the option of ordering Sharklets on new-built aircraft and launched the “Sharklet Project”. Sharklets are large wing-tip devices designed to optimize the

aerodynamics and therefore, improve the fuel-efficiency of an aircraft amongst other operational enhancements.

This article presents the Sharklet retrofit solution Airbus is proposing for the A320 Family aircraft, highlights the benefits that this new device will give the airlines, and also presents the challenges Airbus’ engineers faced during the development of this project.



**Simon GALPIN**  
Head of Airframe Development  
Sharklet Retrofit Project  
Airbus Operations



**François HUGO**  
Sharklet Retrofit Engineering  
Coordination Manager  
Airbus S.A.S.

d

definition

**Vortex shedding** is an unsteady oscillating flow that takes place when a fluid such as air or water flows past a blunt cylindrical body at certain velocities.

## Aerodynamic drag reduction

The aerodynamic efficiency of an aircraft wing depends on its drag, which is made up of:

- Profile drag - driven by surface area of the total airframe,
- Wave drag - driven by transonic shocks, mostly on the wing,
- Vortex drag (also known as induced drag) - driven by lift creation.

Sharklets especially act to reduce the vortex drag. When the faster moving air along the top of the wing meets the slow moving air underneath the wing tip, it creates swirling vortex of air known as a “wing tip vortex”. Through this, the wing is continuously shedding vorticity (related to vortices) into its wake; this shedding is particularly concentrated in the wing tip region, resulting in the wing tip vortices which are commonly visible when aircraft are flying in suitable atmospheric conditions.

In fact, the vortex drag component for transport aircraft flying at transonic speeds represents around 50% of the total aircraft drag. Since engine thrust is required to overcome this drag, it is clearly essential to achieve the lowest vortex drag level possible for an aircraft in order to minimize its fuel burn, so long as the measures involved are suitably traded against weight.

A320 with wing tip fences

Figure 1



There are a number of means to reduce the vortex drag of an aircraft by:

- Increasing the wing span,
- Increasing the effective span by adding near vertical elements to the wing tip, effectively increasing the length of trailing edge,
- Adjusting how the lift generated by the wing is distributed along its span.

Unfortunately, all of the above is usually accompanied by weight increase, hence the need to balance drag and weight very carefully in coming up with an optimum wing design.

The wing tip fences shown in figure 1 - as seen on the A380 and the A320 ceo (current engine option) - work by modifying the wing lift distribution. Such devices have particular advantages. As they are compact in span, they can easily be added to wings where the wing box tip is already close to the aircraft's airport gate limit. They also lead to relatively small increases in the aircraft and especially wing loads. However, the benefit they provide is correspondingly modest.

Sharklets provide larger induced drag reductions than wing tip fences by creating much more significant changes to the wing loading and effective span. These offer the scope for large fuel burn reductions in cruise and significant improvements in climb performance.

## The Sharklet retrofit for the in-service fleet

After the success of the Sharklet option for new aircraft and following customers' requests, Airbus has started the Sharklet retrofit project.

This retrofit option will provide customers with the opportunity to upgrade their existing fleet of A319s and A320s (followed by the A321 at a later stage of the project) with Sharklets. Thanks to the Sharklet retrofit (figure 2), the residual values of the A320 Family (new and in-service fleets) will be protected, or even improved.

The Sharklet upgrade package that Airbus offers includes:

- The Sharklets and attachment ribs,
- Outer wing reinforcements,
- Pre-assembled reinforcement kits,
- A detailed Service Bulletin (SB) including embodiment instructions,
- An assessment of avionics pre-requisites and existing “Repairs and Concessions” for the individual aircraft.

The challenge was to be able to offer a cost/weight effective solution with minimum aircraft downtime during the retrofit embodiment.

From the onset, one of the top-level requirements was to minimize the modification to the wing. The retrofit programme had the benefit of being able to use a lot of transferable work from the new aircraft, allowing the programme to rapidly progress from its initial launch to a maturity suitable to offer to Airbus customers.

## Advantages for airlines

From the beginning, it was decided that both the Sharklet retrofit and the linefit Sharklet devices should be identical, and therefore fully interchangeable. Therefore, the benefits of the retrofit solution are nearly the same as those of the production Sharklet option.

The aerodynamic benefits of Sharklets have proven to reduce drag. Hence, the retrofit package will offer operators reduced fuel costs – fuel being one of the most significant operating costs for airlines. Thanks to lower fuel burn, Sharklets also reduce CO<sub>2</sub> emissions and the environmental footprint of the airline.

Another advantage for airlines is the possibility to operate new longer routes. With the fuel burn reduction, retrofitted aircraft will be able to reach further destinations with the same tank capacity. The device creates new opportunities for airlines. Sharklet-equipped aircraft either will be able to reach new destinations, or will be able to increase the number of passengers onboard. Currently, on certain routes and due to fuel restrictions, airlines cannot operate at maximum passenger capacity. Thanks again to Sharklets, the retrofitted-fleet airline will be able to receive more passengers onboard, for these restricted routes.

Sharklet equipped aircraft can provide benefits to airlines in climb-limited airports. Indeed, thanks to better climb capabilities, a Sharklet equipped aircraft has better take-off performance. Hence, it can operate more efficiently from high, hot, obstacle-limited, weight-limited and noise-restricted airports. Airlines can also recover better payload capability thanks to Sharklets.

Due to a reduced overall aircraft drag, a retrofitted aircraft needs lower engine thrust in cruise and in some cases, at take-off and during climb. Therefore, engine maintenance cost diminishes and the engine’s life is extended.

### Airbus Sharklet

Figure 2

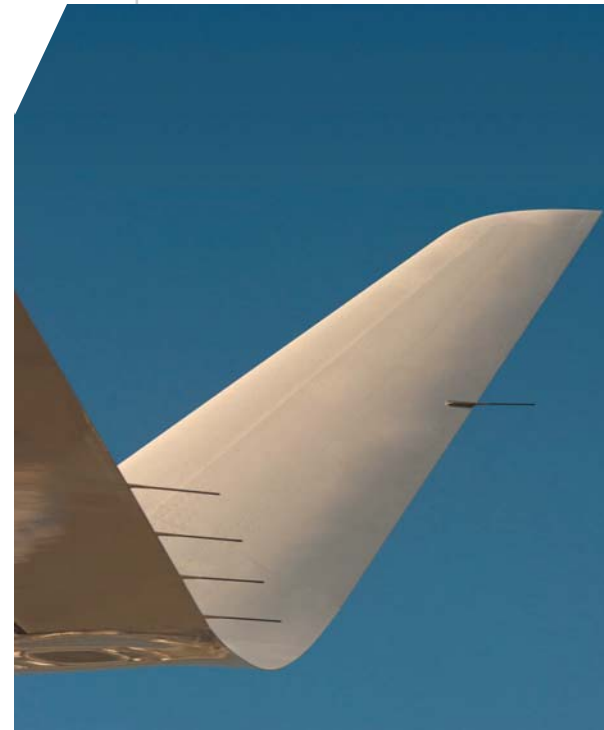

n

notes

#### Line fit / forward fit:

The aircraft comes equipped from the Final Assembly Line (FAL).

## The Sharklet retrofit challenges

Attaching the Sharklets increases the static and fatigue loads in the A319 and A320 wings.

Therefore, their original wing design had to be reinforced to be able to carry the additional loads introduced by the Sharklet. The forward fit wing reinforcement design is ideal for production, but it would require a very long downtime and the associated costs would be too high. This means the retrofit design team needed to create a unique solution.

The first major design challenge was to create a wing reinforcement strategy that did not downgrade the aircraft's performance, compared to the forward fit. Therefore, the wing shape, twist, and stiffness of the retrofit wings needed to be similar to the forward fit. In addition, the reinforcement kit weight could not exceed 200 kilograms, since all added weight would have offset the benefit of the Sharklet device.

The second major challenge was to create a retrofit package that would be attractive and viable for customers. Therefore as a baseline, the retrofit package has been designed so that the aircraft retrofit embodiment time would be minimized and the impact on structural fatigue be reduced.

The added challenge was that the solution needed to use typical MRO (Maintenance Repair and Overhaul) organisation methods and tools.

The third major challenge for the reinforcement design was that it needed to be embodied on existing aircraft and was restricted to the wing. Therefore, the reinforcement needed to be integrated into the existing structure and systems including high lift, fuel, control systems, and consider variants of the aircraft to enable the modification to apply to as many A319/A320 aircraft as possible.

The last challenge is called the "downtime challenge". Downtime refers to the time an aircraft is not flying and not profitable for the airline. Therefore, the design, kitting and embodiment process had to be optimized to minimize aircraft downtime and to be possibly installed in MRO facilities.

In summary, the Sharklet retrofit is a significant multi-disciplinary design challenge!

## The demonstrator programme

Airbus launched a demonstrator programme (figure 3) in order to support the design and development of the Sharklet retrofit solution by running a series of realistic trials for the modification.

The advantage of demonstrator programmes is to offer a retrofit solution based on feedback gained from realistic trials, matching a similar scenario that could be found in an MRO organisation environment. Therefore, Airbus' design department was able to deliver a design solution based on the feedback received, which worked in theory and in practice (figure 4), either at a customer's and/or in MRO facilities.

Trials on a scrap wing at Airbus Filton (U.K.)

Figure 3



MSN1 during working party

Figure 4





The demonstrator programme was split into three embodiment phases, using scrap aircraft wings to realistically test the embodiment design (figure 5) at various stages of the design development:

### THE THREE PHASES

#### PHASE 1:

During this trial, Airbus' engineers have used half a scrap wing. They have disassembled the outer wing, investigated the reinforcement methods and tested the outer wing (bathtub) installation. This phase has provided the design team with valuable feedback in relation to the operator's access, structural constraints and the embodiment steps.

#### PHASE 2:

The phase 2 aimed for further assessing and confirming the retrofit embodiment strategy. This trial supported the detailed design of the retrofit modifications and tooling design. During the series of tests, the design team have further investigated and refined the system's removal, skin reinforcement and bathtub installation. In addition, Airbus has taken the opportunity to test new technologies including a hand held accurate geometry laser scanner and an e-drill.

#### PHASE 3:

This phase of the embodiment trial demonstrated the embodiment strategy by realistically simulating the Sharklet retrofit using tools and representative kit parts on a complete aircraft. This trial has been timed to allow an accurate assessment of the downtime required for customers to retrofit their aircraft with Sharklets.

The Sharklet retrofit wing reinforcement parts

Figure 5

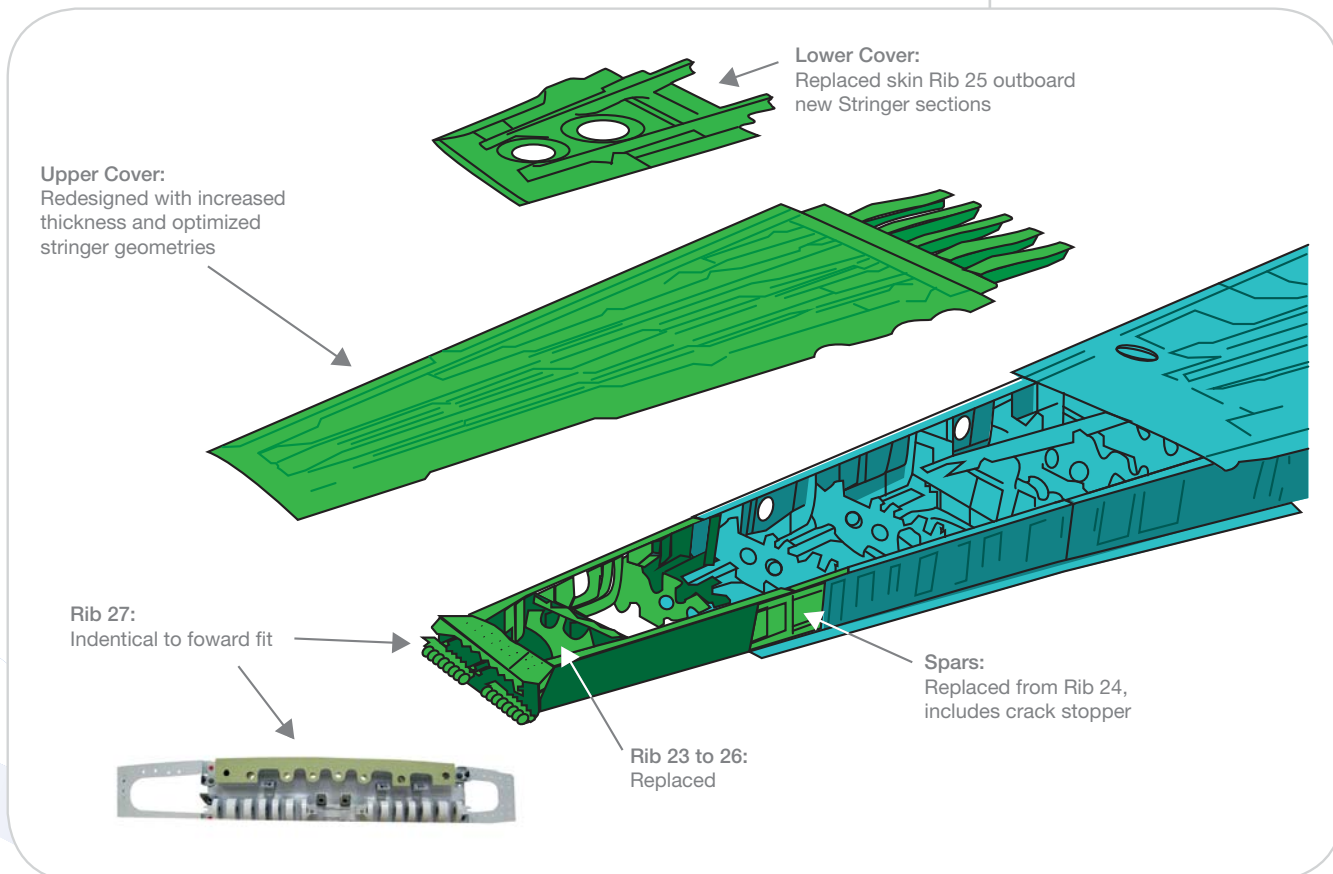

## The retrofit kit

Based on the wing reinforcement strategy, the retrofit kit includes:

- Sharklets,
- New outer wing assemblies including the Sharklet attachment ribs and a new top skin from position 21 to 27,
- Outer wing reinforcements, including stringer reinforcements and outer wing joining parts,
- Retrofit embodiment tooling,
- Supporting methodology for airlines and MRO organisations to be able to install the retrofit package.

### The Sharklet retrofit kit

Figure 6

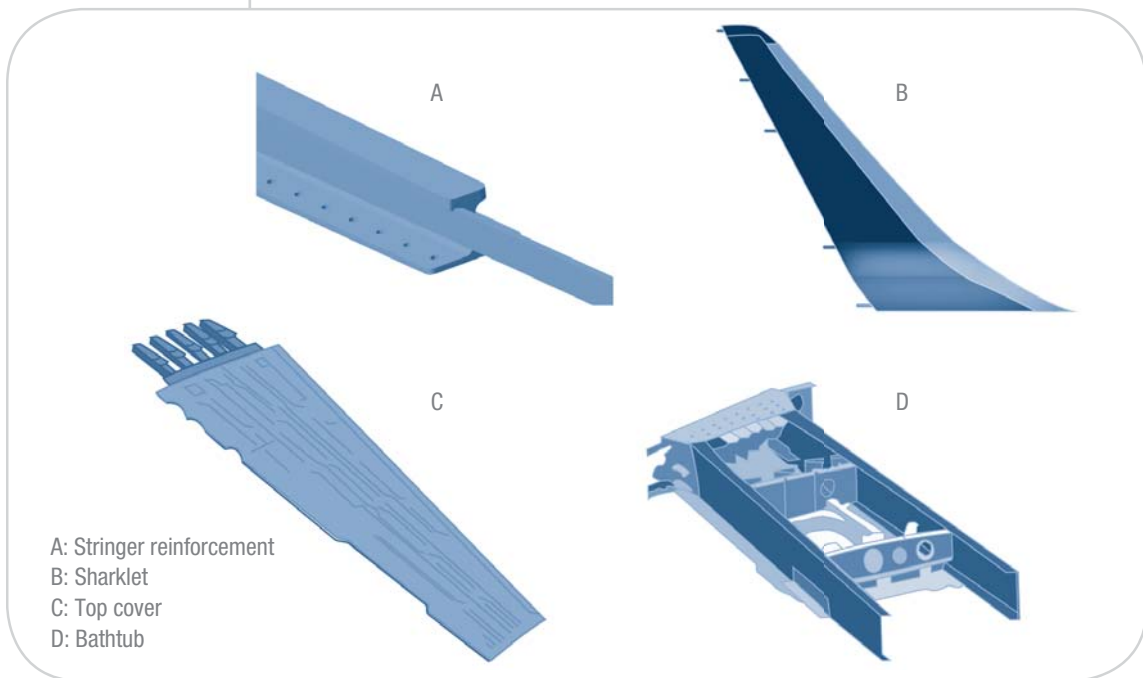

### CONTACT DETAILS

#### Simon GALPIN

Head of Airframe Development  
Sharklet Retrofit Project  
Airbus Operations  
Tel: +44 (0)117 936 7517  
simon.galpin@airbus.com

#### François HUGO

Sharklet Retrofit Engineering  
Coordination Manager  
Airbus S.A.S.  
Tel: +33 (0)5 62 11 81 37  
francois.hugo@airbus.com

## Conclusion

Thanks to improved aerodynamics, Sharklet-equipped aircraft will benefit from (but not only) reduced fuel burn, lowered CO<sub>2</sub> emissions and additional passenger revenue potential.

The Sharklet retrofit project is the result of Airbus engineers' work. Adapting the Sharklet solution to a retrofit situation is not an easy task due to technical and operational constraints. The wing reinforcement must be light enough to not downgrade the performance improvement

and the aircraft downtime must be reasonable in order for the solution to be interesting for the airlines. Airbus' engineers have undertaken a long and complex set of trials in order to adapt the Sharklets to a retrofit solution and to empirically test the retrofit approach. To date, the project has succeeded in facing the challenges.

Available for the A319 and A320 aircraft in the first phase, and the A321 at a later stage, the first Sharklet-retrofitted aircraft is expected to enter into service mid 2014.

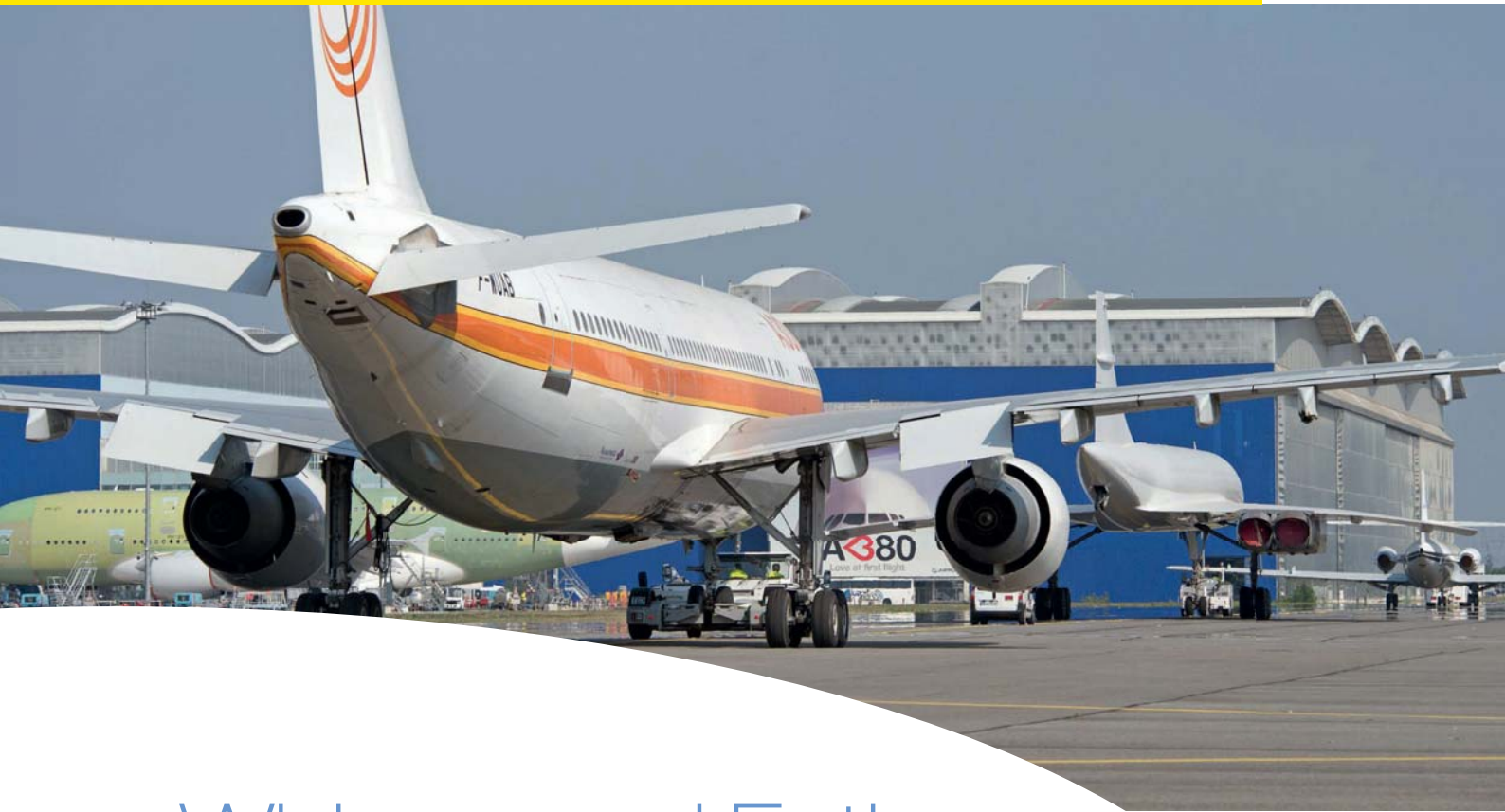

# Widespread Fatigue Damage

## A300B: Compliance with ageing aircraft regulation

In April 1988, an ageing aircraft suffered major structural damage to its pressurized fuselage, due to undetected fatigue cracking of the primary structure. These cracks, at multiple structural locations, grew and linked up quickly to cause sudden failure of a large section of the fuselage. Airbus decided then to significantly invest in the assessment, for over 15 years, of the A300B's airframe structure and define the necessary maintenance actions. The results of this initial Widespread Fatigue Damage (WFD) assessment were published in 2003, in the frame of the Extended Service Goal (ESG) study.

The aviation regulation evolved over the last 20 years, and the latest WFD regulation is effective from 14<sup>th</sup> January 2011.

Additional activities have been carried out by Airbus in 2012 to demonstrate its compliance with this latest aviation regulation.

It has led to the creation of eight new maintenance tasks (four new inspections and four new modifications), which have to be implemented in the aircraft operators' maintenance programmes, starting in July 2013.

The operation of the A300B is ensured for the decades to come, leading the path for Airbus' entire fleet.



**Nicolas TURREL**  
Structure Analysis Aircraft  
Policies & Programmes  
Airbus S.A.S.



**Didier AURICHE**  
Airframe & Installation  
Airworthiness  
Airbus S.A.S.

## Fatigue cracking of metallic structures

As the aircraft accumulates Flight Cycles (FC) or Flight Hours (FH), cracks may initiate in fatigue sensitive areas (figure 1).

Appropriate inspections and structural modifications are defined and implemented in the operators' maintenance programme to maintain the structural strength of the airframe throughout the service life of the aircraft.

## Widespread Fatigue Damage phenomenon

WFD is characterized by the presence of multiple cracks at adjacent locations over large areas (figure 2). Adjacent cracks may interact with each other and coalesce in longer cracks (i.e.: Small cracks coalesce when they grow up to the point that they form a single long crack - Multiple Site Damage) in a relatively short period.

Crack initiation from a fastener hole (Airbus test specimen)

Figure 1

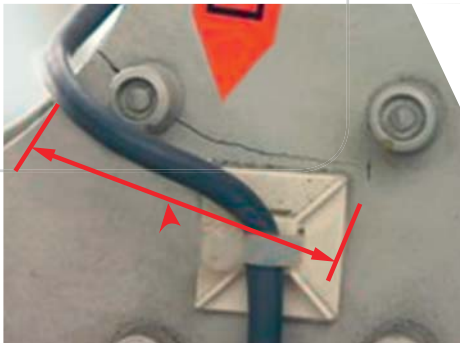

Example of structures susceptible to WFD as per FAA regulation

Figure 3

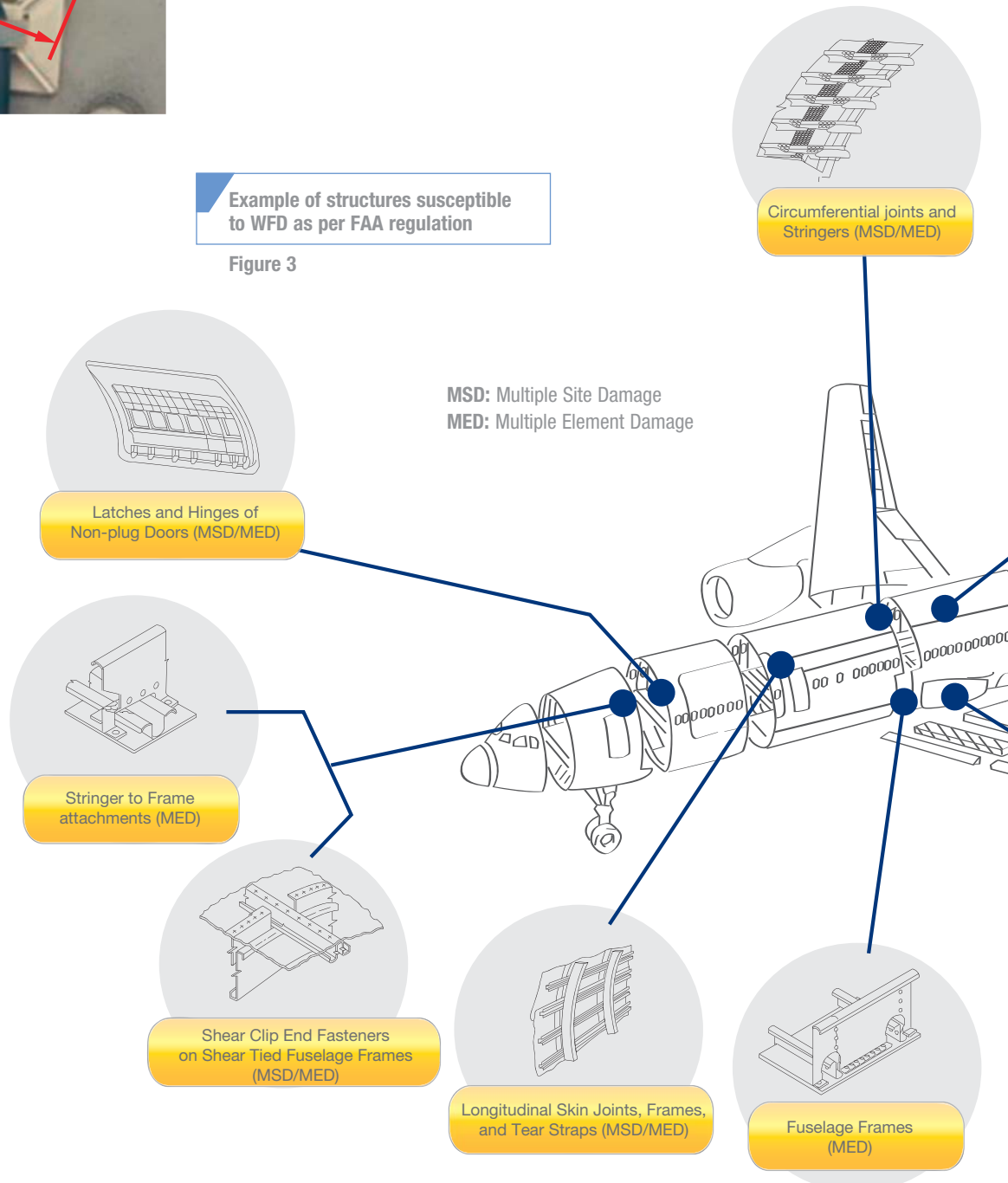

Similarly, the presence of cracks in multiple elements (Multiple Element Damage) may reduce the residual strength capability of the structure. The use of Non-Destructive Techniques (NDT) to find small cracks over large areas inspected may not be a reliable and effective solution in service, compared to laboratory conditions for the tear down of a test specimen.

Due to these specificities, the FAA (Federal Aviation Authority) and industry groups concluded that the

best approach against this phenomenon is to preclude it. To do so, the structure susceptible to WFD (figure 3) shall be modified or replaced early enough in service, to avoid the WFD to occur throughout the service life of the aircraft, up to the Limit Of Validity (LOV).

In structural areas where inspections are shown to be reliable, an inspection phase may be implemented before the modification is applied.

Multiple Site Damage (MSD) evidence from a tested structure

Figure 2

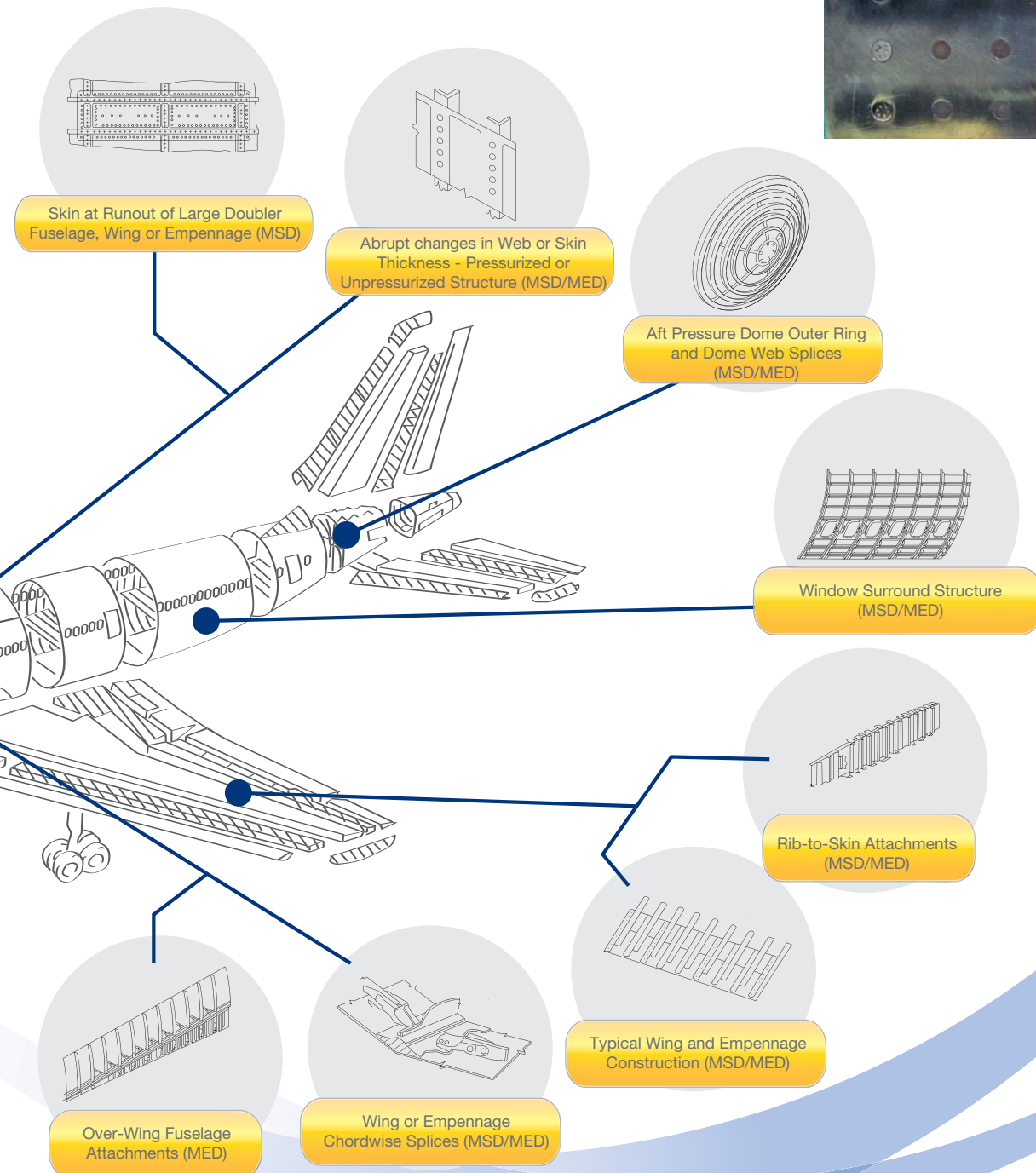
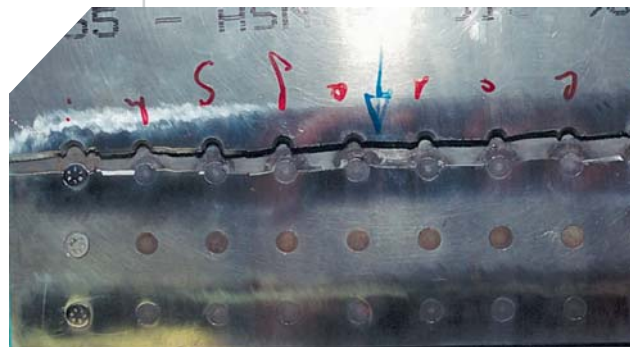

## Ageing aircraft regulation

In response to the April 1988 issue, the FAA sponsored a conference on ageing aircraft and established a task force representing the interests of the operators, aircraft manufacturers, regulatory authorities and other aviation representatives. This task force, which became the Airworthiness Assurance Working Group (AAWG), specifically recommended the establishment of an ageing aircraft programme to address long-term ageing airworthiness issues in aircraft structures. The Widespread Fatigue Damage (WFD) was part of these issues.

The main milestones addressing WFD were (figure 4):

- 1993: Voluntary commitment by the aircraft manufacturers to perform a structural evaluation for WFD on the models certified before the introduction of damage tolerance.

- 1998: Amendment of the FAA regulation requiring at least two life-time Full-Scale Fatigue Tests (FSFT) as part of new Type Certificate (TC) and the establishment of an operational limit. This rule was used to certify the A380 model.
- 2010: Issuance of the FAA WFD regulation requiring the establishment of a Limit Of Validity (LOV) and service actions required to preclude the WFD from the fleet.
- The equivalent EASA (European Aviation Safety Agency) rules on the WFD are expected to be issued in 2013.

The WFD regulation is the latest step of the evolution of fatigue and damage tolerance regulations since the 1950s. The development of the regulation is shown on the timeline (figure 5), with the retrospective application of WFD regulation to the already certified aircraft.

The standards defined since more than 10 years in the frame of the A300/A310 Family life extension and compliance to the WFD regulation in 2012, have already benefitted the assessment of the WFD for the metallic structures of all the other Airbus aircraft programmes.

### Main milestones addressing Widespread Fatigue Damage

Figure 4

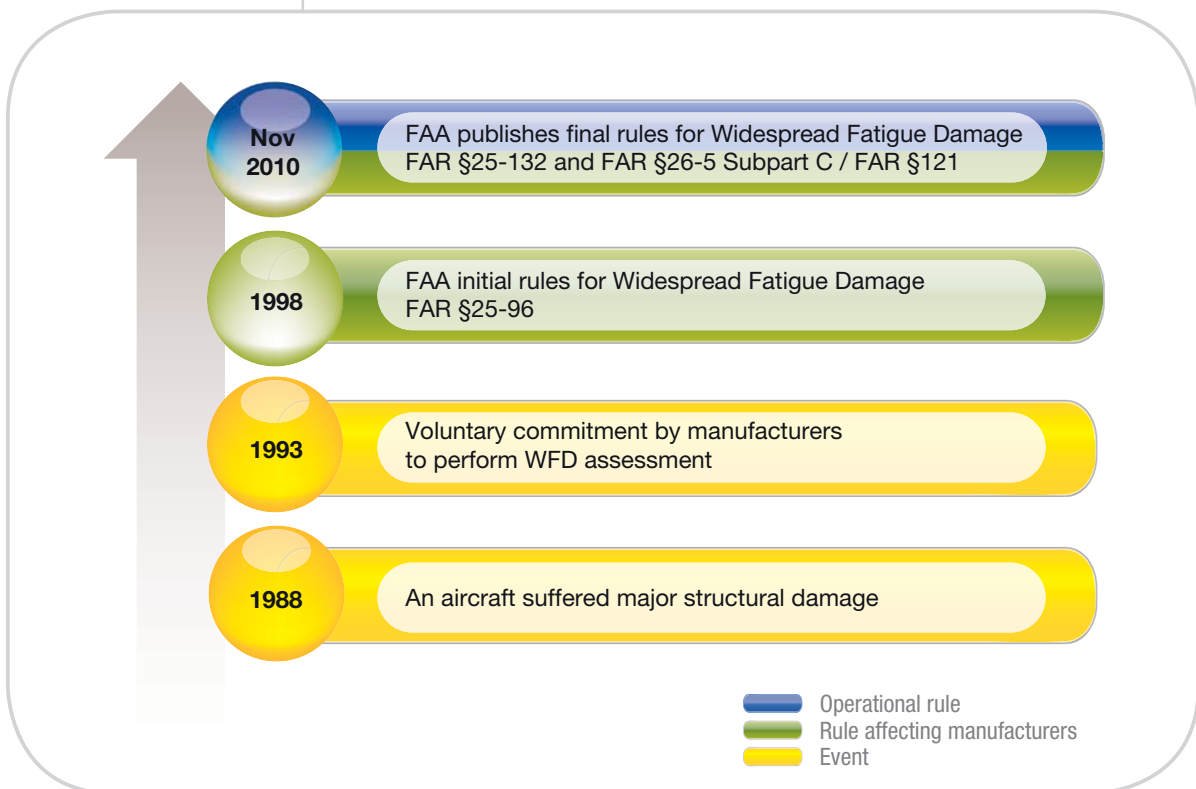

Timeline of Fatigue & Damage Tolerance and WFD evolutions since the 1950's

Figure 5

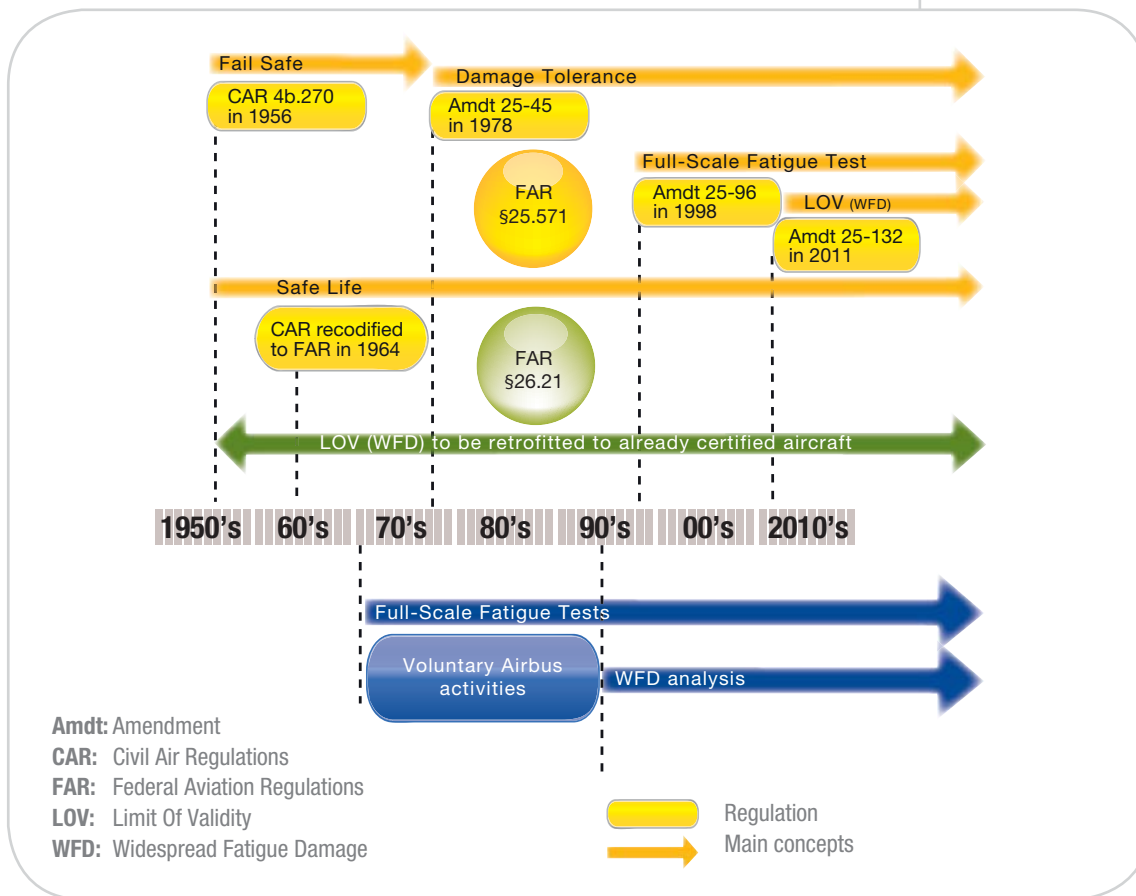

## Assessment for Widespread Fatigue Damage

Even before the FAR §25.571 Amendment 96, requiring two life-time Full-Scale Fatigue Tests (FSFT), Airbus' philosophy was to anticipate it. Airbus has always performed extensive FSFT on each

Airbus family fleet, from the A300/A310 Family to the A380 today (figure 6), and tomorrow for the A350. This philosophy is aiming to detect and 'find a fix' for any fatigue cracking issue before it occurs in service. These tests constitute the corner stone of the assessment for WFD.



FSFT performed on each Airbus aircraft programme since 1970's - here for the A380

Figure 6



Fast 45 - Extended Service Goal article

**i**

information

**Steps of the WFD evaluation:**

- 1) Identify structures susceptible to WFD
- 2) Predict when WFD is likely to occur
- 3) Establish appropriate maintenance actions to preclude WFD

**d**

definitions

**Design Service Goal (DSG):**

The reference figure used for design and justification for Type Certification. It reflects the utilisation of the aircraft model for about 20-25 years of the expected aircraft service.

**Extended Service Goal (ESG):**

An extension of the DSG, providing five to six additional years' service. The ESG exercise for Airbus' aircraft typically includes in-service fleet experience, analysis supported by new development tests and the WFD assessment.

**Limit Of Validity (LOV):**

The period of time during which it is demonstrated that the WFD will not occur on the aircraft structure. Airbus historically introduced a LOV in its maintenance programmes before the issuance of the WFD regulation, applicable to the engineering data that supports the structural maintenance programme.

Airbus initiated activities on the WFD phenomenon in the early 1990s. Simulations of multiple cracking scenarios have been developed to predict the initiation and propagation of cracks in the airframe structures susceptible to WFD.

On top of the Full-Scale Fatigue Tests (FSFT), a wide range of coupon to component tests were performed to support and validate these method developments.

Evidence of WFD situations have been experienced on longitudinal and circumferential joints during the fuselage barrel and FSFT. These cases allowed calibrating the assessment methods used afterwards to design and certify structures. Serial and retrofit modifications were also defined and implemented on the A300/A310 Family.

In 2011, following the issuance of the WFD regulation, Airbus has developed a dedicated structure analysis policy, addressing all steps of the WFD evaluation in detail (see steps in the side box), in order to ensure a consistent approach for the entire airframe, throughout the Airbus programmes. A collaborative work with the EASA and FAA has been

performed to reach an agreement on Airbus' means to show compliance to this regulation for all Airbus aircraft.

Thanks to this anticipation philosophy, there has been no evidence of WFD findings on Airbus aircraft in service, so far. Furthermore, the establishment of a LOV (Limit Of Validity) of the maintenance programme, as requested by the WFD regulation published in 2010, is already in place for almost 10 years on all Airbus aircraft.

## WFD regulation compliance for the A300B aircraft

An assessment for the WFD was already performed on the A300/A310 Family fleet as part of the ESG (Extended Service Goal) activities (FAST 45), prior to the FAR §26.21 issuance.

The assessment included specific analysis, supported by additional coupon and panel tests, tear-down of retired high time aircraft, and additional tear-down of the original certification Full-Scale Fatigue Test specimen.



Additional evaluations were required and carried out by Airbus to be fully in line with FAR §26.21. A complete set of engineering data supporting the assessment has been provided by Airbus to the FAA in the first half of 2012 to comply with the FAR §26.21. The outcome of the FAR §26.21 compliance is the:

- Validation of the LOV (established for life extension) in the frame of the WFD assessment,

- Identification, development and notification to the operators of the additional required maintenance actions to preclude the WFD.

This assessment for FAR §26.21 led to the creation of eight new maintenance tasks (figure 7), which have to be implemented in the aircraft operators' maintenance programmes, starting July 2013.

Number of maintenance actions created after compliance with FAR §26.21 to reach the LOV

TYPE	LOV	ESG (2003)	WFD (2012)	
A300-B2-1C A300-B2K-3C A300-B2-203	60,000 FC			
		37 tasks created	4 inspections created	1 MSB (2013) 1 MSB (2014) 1 MSB (2021) 1 MSB (2037)
A300-B4-2C A300-B4-103 A300-B4-120 A300-B4-203 A300-B4-220	57,000 FC			

Figure 7

**ESG:** Extended Service Goal  
**FC:** Flight Cycle  
**LOV:** Limit Of Validity  
**MSB:** Modification Service Bulletin  
**WFD:** Widespread Fatigue Damage

**CONTACT DETAILS**

<p><b>Nicolas TURREL</b>                  Structure Analysis Aircraft Policies &amp; Programmes                  Airbus S.A.S.                  Tel: +33 (0)5 61 18 98 45                  nicolas.turrel@airbus.com</p>	<p><b>Didier AURICHE</b>                  Airframe &amp; Installation Airworthiness                  Airbus S.A.S.                  Tel: +33 (0)5 61 93 48 23                  didier.auriche@airbus.com</p>
--	--

# Conclusion

Airbus has already acquired 15 years of experience assessing Widespread Fatigue Damage (WFD), and more than 20 years knowledge of this phenomenon. Airbus' approach, including the Full-Scale Fatigue Tests and the establishment of the Limit Of Validity (LOV) in the maintenance programme, should allow a smooth transition towards compliance with the WFD regulation.

Since 31<sup>st</sup> August 2012, the A300B is the first Airbus aircraft to be compliant with the WFD regulation. The work achieved sets the standards of approach and methods to be followed in the next years for the entire Airbus Family, including any new Type Certification (TC) to come. It leads the path for the future compliance of all Airbus aircraft programmes.



# Optimized spare parts investment

## Initial Provisioning influencing A350 XWB development

The development of future aircraft models is challenged by technological, logistical and economical demands as well as the customers' specific expectations. However, the development and production phase is not the only challenge an aircraft manufacturer faces today. Following the Entry-Into-Service (EIS) of a new aircraft, a close customer relationship with a high level of trust must be established and maintained. The introduction of lifecycle support initiatives, to ensure highly efficient operating costs, is fundamental in achieving this.

One such initiative is the optimization of high value spares' investments. For the A350 XWB (Extra Wide Body), Airbus has implemented an enhanced process to set up a new spare part recommendation forecast at an earlier stage of aircraft development, to ensure that spares-related criteria influence design requirements. Therefore, spares specific Top Level Aircraft Requirements (TLAR) were implemented to reduce the investment costs whilst ensuring continuous operating and maintenance improvements.



**Stefan TRINKER**  
Integrated Provisioning Services  
Project Manager  
New Programmes IP  
Airbus Operations



**Daniel SCHWARZER**  
Integrated Provisioning Services  
Material & Logistics Engineer  
Airbus Operations

## A350 XWB Initial Provisioning cost reduction

Airbus' A350 XWB Initial Provisioning (IP) initiative defines all the targeted aircraft and component performances that impact IP costs, as well as Cost Of Ownership (COO). By feeding this spares relevant information into the Top Level Aircraft Requirements (TLAR) during an earlier stage of the A350 XWB development, it ensures that the targets are met throughout the design process and mature data can be cascaded towards the suppliers in the designated specifications and in accordance with the contractual agreements.

For new aircraft programmes, it is challenging to estimate the IP budget owing to a lack of in-service data and experience from new cutting edge technologies. For the A350 XWB, Airbus therefore uses experience in operational support to set a standardized and verified baseline against a similar twin-engine aircraft with similar long range operational requirements: The A330-300. This baseline was defined as a typical 10-aircraft fleet of A330-300s with identical standard configurations and typical utilisation parameters.

Based on the baseline assumptions for IP, a Recommended Spare Parts List (RSPL) can be compiled to determine the typical fleet IP investment. The RSPL provides the total recommended investment for all Seller Furnished Equipment (SFE) and Line Replaceable Units (LRUs) installed on the fleet (excluding engine, Ground Support Equipment (GSE) and tools).

For the A350 XWB, highly customized airline differentiation parts such as In-Flight Entertainment (IFE) and seats are handled through a new supplier support agreement named ACS (Airbus Contracted Supplier).

Due to the 'ACS Selection Agreement', the customer has the advantage of being responsible for selecting the ACS, the product and its features in accordance with the relevant Aircraft Description Document (ADD) customization sections, whilst Airbus has the contractual assurance of quality, on-time delivery and installation of these ACS parts. For a complete data set, ACS parts will be listed within A350 XWB Recommended Spare Parts Lists, but because customers negotiate directly with ACSs, Airbus desists from any recommendations.

The total investment target defined in the TLAR for an A350 XWB fleet will be reduced by around 5% compared to one composed of A330-300.

Description of the ACS contractual relationship

Figure 1

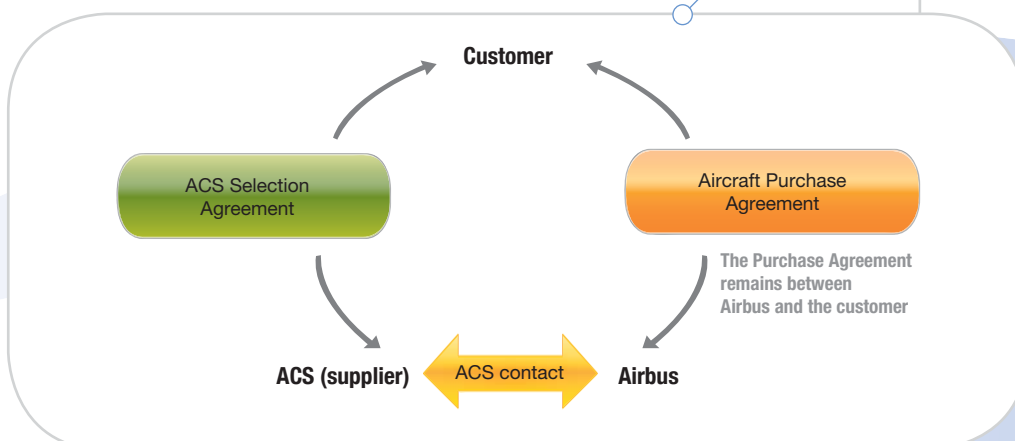

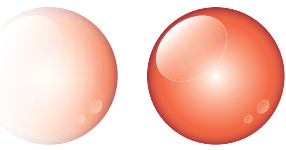

CPIOM reduced from three to two on the A350 XWB programme

Courtesy of Thales

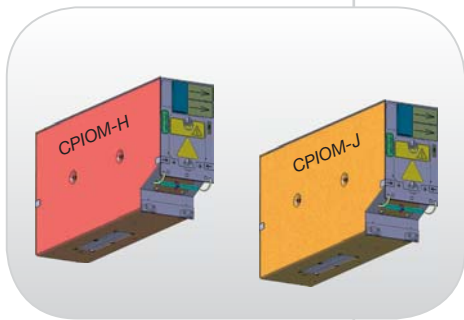

The global investment has been broken down into individual targets per ATA (Air Transport Association) chapter. With the A350 XWB's advanced technologies, a number of systems feature new designs, functions or materials. Therefore, they also have different performances compared to current technologies, with a direct impact on the required investment. For this reason each ATA chapter has been monitored by the A350 XWB programme management to meet the target.

**AN EXAMPLE WITH ATA 34 - NAVIGATION CHAPTER**

An example (shown in figure 3) in achieving the reduced IP investment targets is the re-engineering of the environmental surveillance functionality. In comparison to the A330-300 IP baseline, consisting of several individual reporting systems, the A350 XWB features a highly reliable, integrated Aircraft Environment Surveillance System (AESS) with fewer components.

**A350 IP target cost objective**

Figure 3

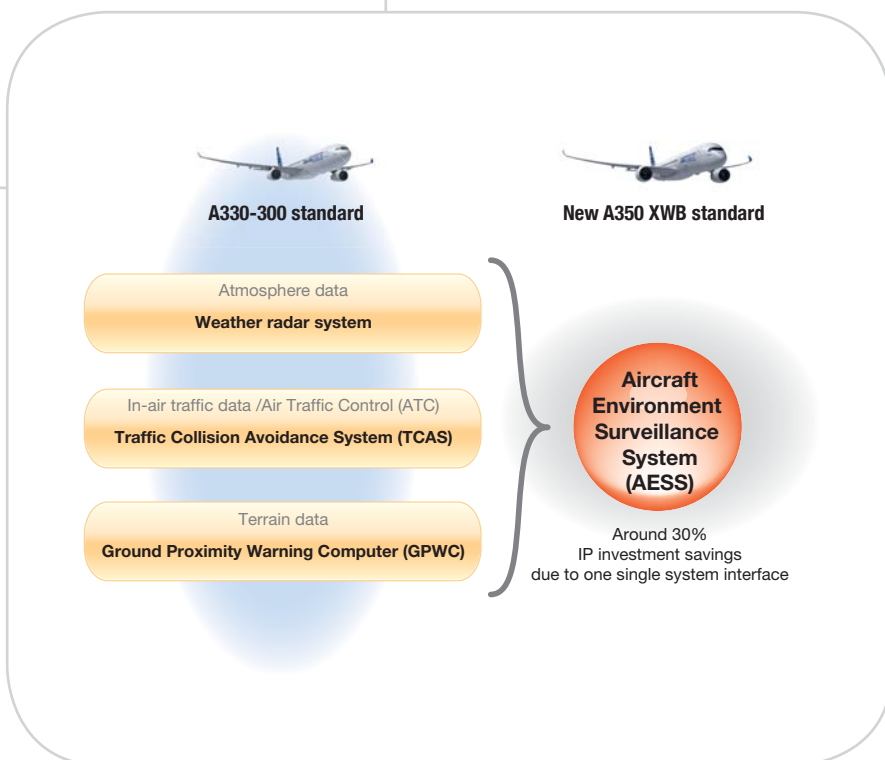

This new AESS detects possible external dangerous factors that can have an impact on the aircraft's flight path and reports them on one single device. Safety relevant factors include weather conditions or terrain proximity.

**HOW IP CAN INFLUENCE PART DEVELOPMENT**

For the A380, as well as the upcoming A350 XWB, a new Integrated Modular Avionics (IMA) concept has been developed. In contrast to conventional avionics, the IMA principle is to provide shared hardware resources for computing and communication functions. The Core Processing Input/Output Module (CPIOM), as part of the IMA, hosts avionics' applications and processes data to execute avionics' functions. These CPIOMs are spread between two configuration types: H & J. They differ in their definition of physical interfaces; CPIOMs of the same cluster can be exchanged without the need of a software upload.

The initial engineering feasibility study for the A350 XWB proposed an uneven distribution between these two CPIOM models with an effective outcome of three recommended spare modules per aircraft.

Due to the new spares' TLAR settings, this distribution has been re-analysed with the conclusion that an even distribution could reduce the amount of recommended modules, reducing the investment by one third.

## A350 XWB general development and IP

In comparison to previous aircraft programmes, the IP target cost for Top Level Aircraft Requirements (TLAR) of the A350 XWB has been implemented during an early stage of development. Due to this early integration, spares' criteria such as the IP investment can now be handled as design requirements for the A350 XWB.

### VALIDATION AND VERIFICATION ENSURES A SUCCESSFUL MATERIAL READINESS CONFERENCE

The analysis of spare part provisioning for the A330-300 has identified the parts which have the greatest impact on the IP target cost of system and cabin related Line Replaceable Units (LRU).

The A330-300 is used as a reference to represent the basic quantity of expected vendor parts for the A350 XWB Recommended Spare Parts List (RSPL), including nacelle components. Engineering and operability expertise gained over previous programmes has

facilitated the validation and verification process amongst stakeholders (figure 4/[A]). For the A350 XWB, all contracted suppliers are now obliged to send preliminary LRU information as well as their updates. These Maintenance Maintainability Evaluations (MME) documents are verified and used for initial recommendation calculations. Once the Critical Design Review (CDR) has been successfully passed, all RSPL-relevant part attributes are contractually fixed (figure 4/[B]).

Because new technological developments and highly integrated aircraft components are usually impacted by a variety of changes, a high number of modifications are to be expected.

Airbus must secure validated supplier information to support the Material Readiness Conferences with customers (figure 4/[C]). For this target, Airbus has to approve supplier offers according to the Supplier Support Conditions (SSC) agreements prior to the first Material Readiness Conference. These SSC contracts are regulating the main spares' provisioning related items (e.g.: commercial and technical deliverables).



#### information

The Material Readiness Conference (MRC) is part of a comprehensive Material Readiness Roadmap (MRR) helping to prepare a smooth Entry-Into-Service for each customer. The MRC represents a combined meeting between customers, top-tier-suppliers and Airbus to present and discuss all potential Initial Provisioning related topics in detail with special attention to Line Replaceable Units which account for roughly 80% of the investment value, although they only represent 20% of recommended spare parts.

Milestones for an aircraft development

Figure 4

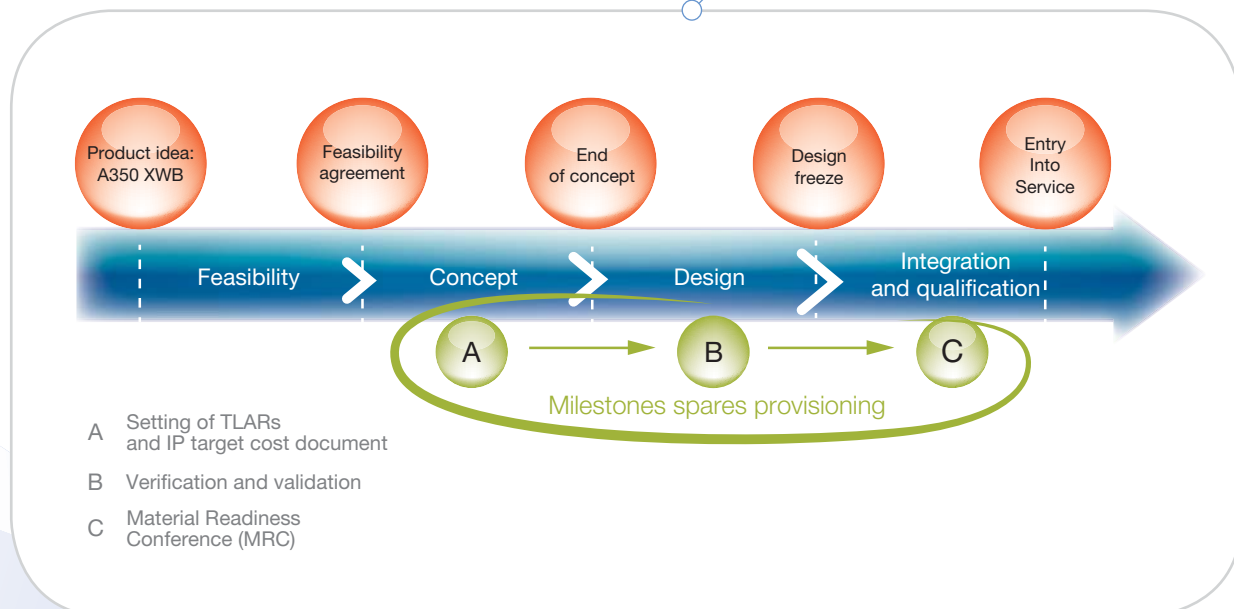

## Ensuring suppliers' deliverables

For the A350 XWB's advanced technologies, Airbus has contracted numerous new suppliers. A dedicated process has been set in place to ensure that new suppliers will be able to fulfil their contractual obligations regarding quality and delivering on time.

In addition to routine support measures (e.g. customized requests on Part Number level, superior maturity meetings, etc.), Airbus also conducts Initial Provisioning workshops with suppliers to:

- Guarantee early integration and collaboration between Airbus and external A350 XWB stakeholders to consistently maintain awareness of deliverable deadlines, dates and formats,
- Review the current status, discuss discrepancies, change requests and organize a homogenous way forward,
- Communicate at the right time with the people that are responsible for ensuring the expected results.



### CONTACT DETAILS

#### Stefan TRINKER

Integrated Provisioning Services  
Project Manager  
New Programmes IP  
Airbus Operations  
Tel: +49 (0) 40 5076 2446  
stefan.trinker@airbus.com

#### Daniel SCHWARZER

Integrated Provisioning Services  
Material & Logistics Engineer  
Airbus Operations  
Tel: +49 (0) 40 5076 1242  
daniel.schwarzer@airbus.com

## Conclusion

In an ideal world the variety of information provided by suppliers, customers and the manufacturer can easily be consolidated and used for validated spares' investment recommendation calculations. But a high number of stakeholders and interfaces significantly increase complexity. For this reason, Airbus decided to pursue a different strategy for the Initial Provisioning development of the A350 XWB.

In detail, Airbus strived to optimize the spares' provisioning process by using spares specific Top Level Aircraft Requirements as a design basis and also by introducing new ways of integrating stakeholders for data validation and verification. This promising new approach will secure a higher maturity level of the Recommended Spare Parts List for the first A350 XWB customers in 2013, with a smooth Entry-Into-Service.

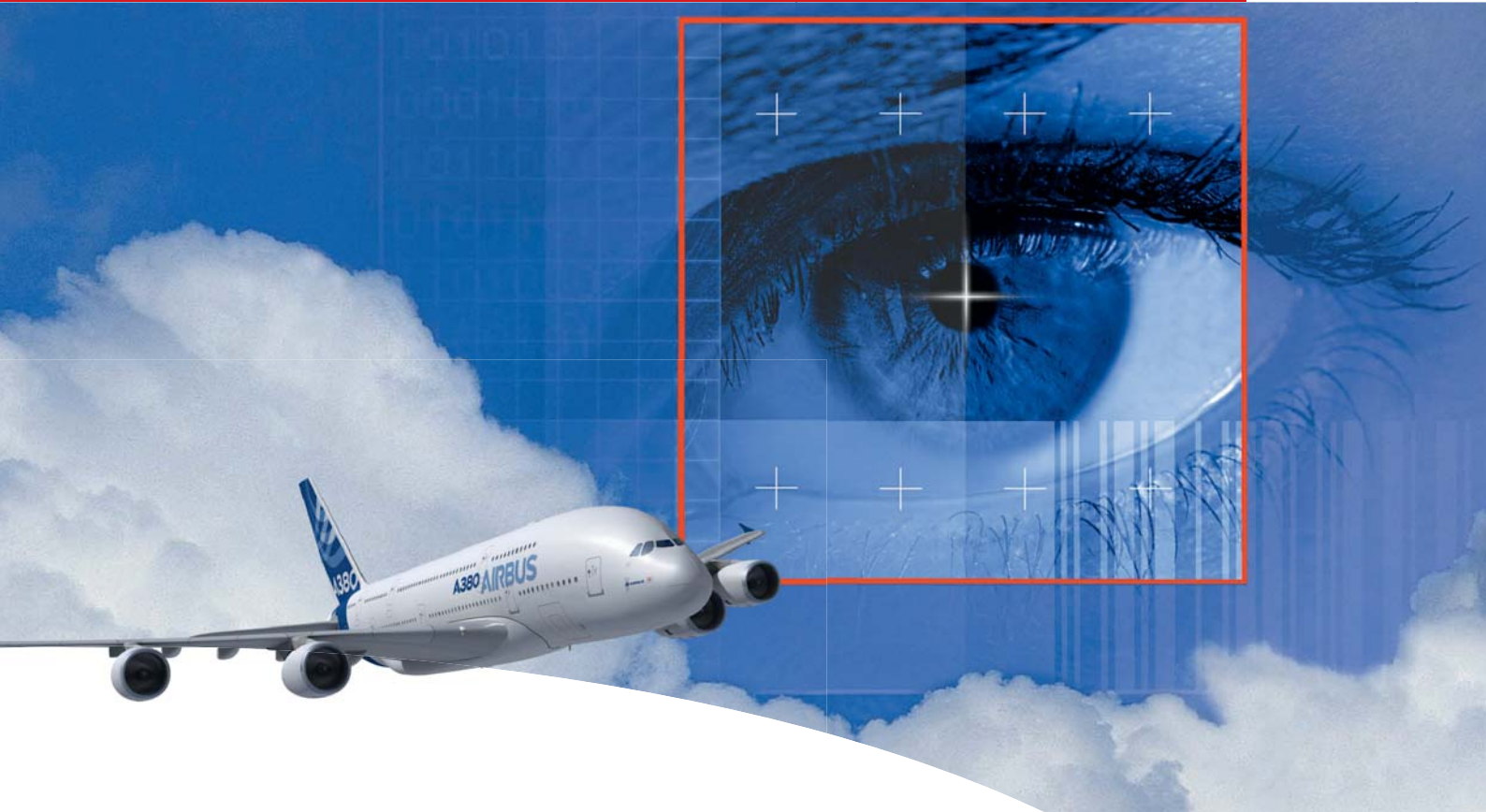

# Managing aircraft security

## A new challenge for the air transportation community

The most important topics for the air transportation community today are safety and security. While physical security threat management remains a major challenge, the management of cyber security is a new and growing objective for all stakeholders of the air transport industry. The new generations of aircraft integrate functions for crews and passengers that rely on Information Systems (IS) that could be targeted by cyber threats.

These new functions require extended connectivity between aircraft systems, the aircraft itself and the ground segments. Aircraft functions and ground dependent functions are more and more supported by commercial off-the-shelf software, products and technologies. To manage these potential new threats, airworthiness authorities have set specific obligations for aircraft manufacturers.



**Pascal ANDREI**  
Head of Aircraft Security  
Airbus S.A.S.



**Gernot LADSTAEFFER**  
Head of Aircraft In-Service Security  
Airbus S.A.S.



**Isabelle DUFEU**  
Aircraft Security  
Special Projects Manager  
Airbus S.A.S.

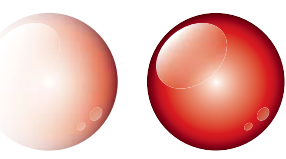

## Setting the picture

Everybody knows about traditional threats and how the diversity and increasing intensity of malicious acts may target aircraft or passengers (figure 1). Regularly, press articles relate cyber attacks against air/ground communication systems, or increasing numbers of laser cockpit illuminations reported by airlines.

All Airbus aircraft, by design, are compliant with their own applicable requirements. Airbus has demonstrated through design, activities and processes that the airworthiness authorities' security requirements are fulfilled for the whole aircraft lifecycle. For the A350, experiences from the A380 as well as industry standardisation activities have been used to ensure streamlined security solutions.

Evolutions of the legacy programmes towards more connectivity and more IT (Information Technology) on board-based solutions are assessed by a dedicated aircraft security organisation to ensure that aircraft security is not jeopardised.

## Aircraft safety versus aircraft security

To avoid any misunderstanding, it is key to cover the scope and definitions:

### Aircraft security:

Concerns the prevention of deliberate malicious acts that may affect the aircraft and/or the passengers (hacking, malicious code, unruly passenger, hijacking, explosive devices, etc.).

### Aircraft safety:

Concerns the reduction and control of risks associated with aircraft operations to an acceptable level.

Potential source of treats

Figure 1

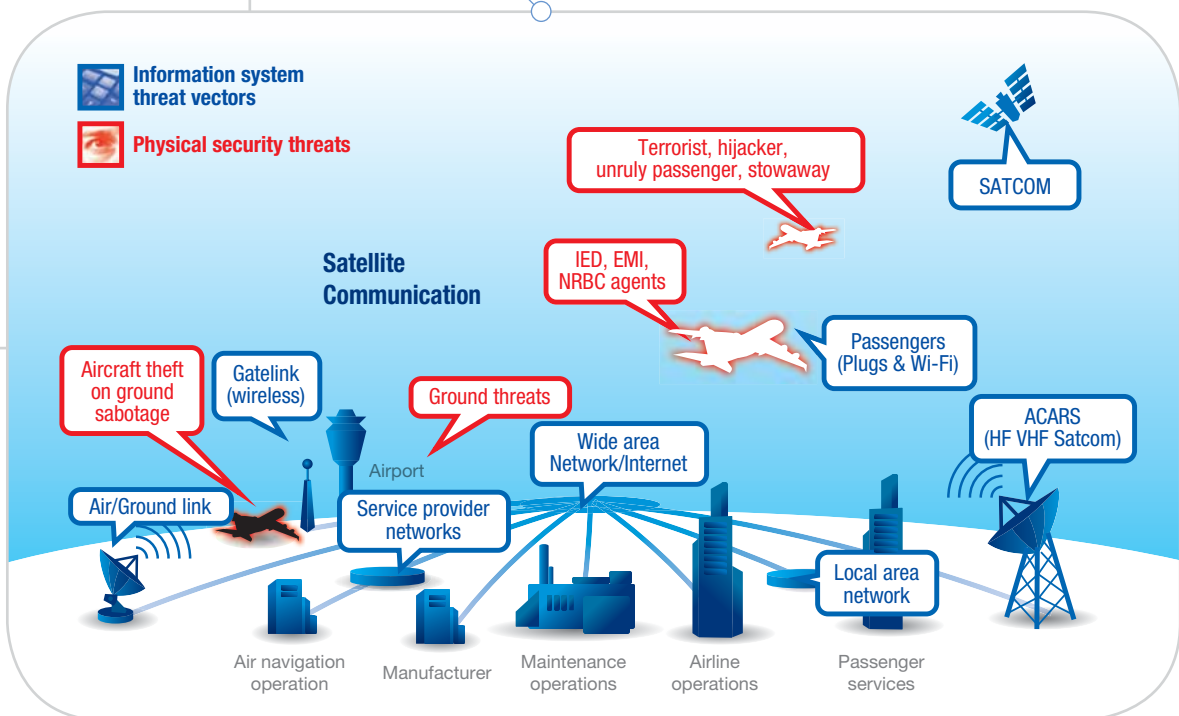

**ACARS:** Aircraft Communication Addressing and Reporting System / **EMI:** Electromagnetic Interference / **HF:** High Frequency  
**IED:** Improvised Explosive Device / **NRBC agents:** Nuclear Radiological Biological Chemical / **SATCOM:** Satellite Communication  
**VHF:** Very High Frequency / **Wi-Fi:** Wireless Fidelity



## Physical security features

One of the physical security concerns is to protect the aircraft and its passengers by deterring or preventing non-authorized people from particularly sensitive areas of the aircraft.

It addresses a large scope of potential threats, including:

- Aircraft seizure for blackmail purposes or for use as a weapon,
- The use of Improvised Explosive Devices (IED) or incendiary devices taken on board,
- Aircraft sabotage on ground (unsecured aircraft and/or unsupervised parking stands),
- Aircraft ground attack (MANPADS, laser, etc.),
- Contamination of crew and passengers with biological or chemical agents,

In figure 2, you will find some of the security features that have been developed and implemented to answer the operators' needs over and above regulatory standards, to mitigate physical threats such as unruly passengers, hijackers, sabotage, etc.

### Examples of physical security features

Figure 2

The **reinforced cockpit door** is a mandatory feature for all aircraft

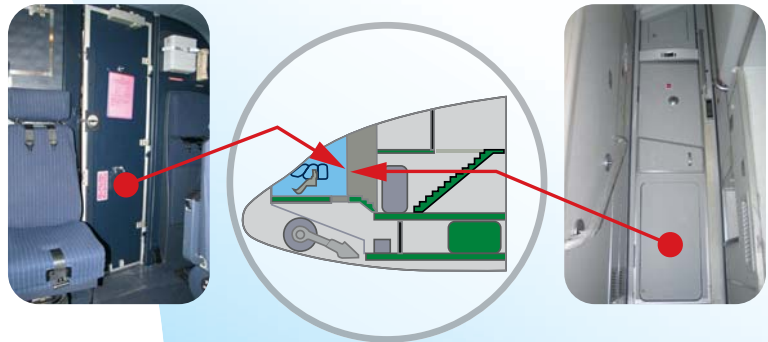

The **privacy door** is an option proposed to airlines on wide-body aircraft to create a secondary barrier to the cockpit area

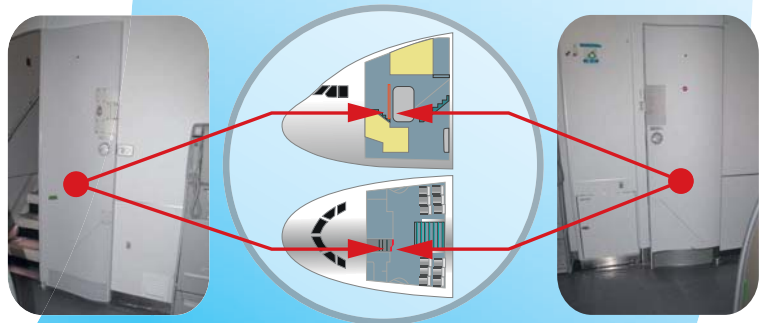

### Cockpit Door Surveillance System (CDSS)

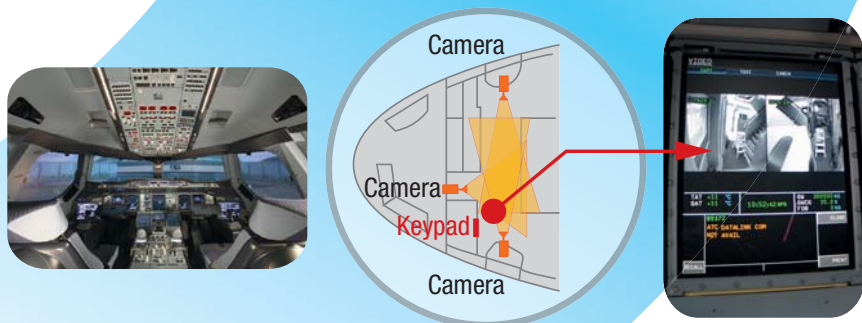

The **Emergency Call Alerting System** (option) may be used to alert the cockpit in case of an incident in the cabin



Overhead luggage compartment design modification to facilitate cabin searches using a mirror

Figure 3

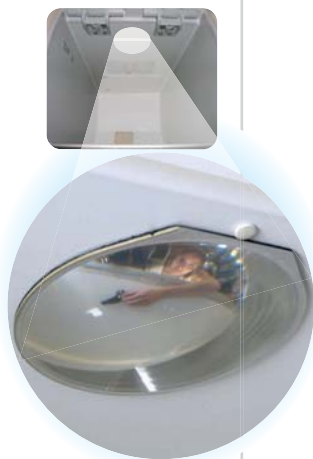

g

glossary

- ACARS:** Aircraft Communication Addressing and Reporting System
- HF:** High Frequency
- IS:** Information System
- IT:** Information Technology
- SATCOM:** Satellite Communications
- USB:** Universal Serial Bus
- VHF:** Very High Frequency
- WIFI:** Wireless Fidelity

Security research projects

Figure 4

Research on the use of biometry to improve aircraft access control for crew



Also, modifying current designs can facilitate routine security tasks such as cabin searches (figure 3).

This activity also covers research projects (examples in figure 4) in order to anticipate the evolution of threats, to answer operator needs and to continuously improve current solutions.

## Cyber security threats

Cyber security concerns the protection of the aircraft Information System, the aircraft/ground segments and aircraft-to-aircraft communication against electronic threats. The threats considered are human actions (purposeful, casual or accidental actions) using unauthorized access leading to disclosure, corruption or destruction of information.

This type of threat covers various areas of on-ground and/or in-flight communications systems:

- Shipment of software from suppliers to Airbus,
- Maintenance connectivity (portable data loaders, troubleshooting equipment, USB key, IT cards, etc.),
- Aircraft/ground wireless links (Gate-link, telephony, WIFI, etc.),
- Aircraft/ground connectivity (ACARS, HF, VHF, SATCOM, etc.),
- Cabin links accessible to passengers (cabin WIFI, plugs, etc.),
- Etc.

A typical example of cyber threats that can be generic or very specific to an aircraft function is a malicious code specifically crafted to infiltrate or damage a system, software or equipment (viruses, worms, Trojan horses, backdoors, spyware, etc.). As a result, the need of protection of Field Loadable Software against corruption is paramount.

The cyber threat is inherent to IT systems, and may lead to successful intrusions on systems with restricted accesses (unauthorized system access: Information modification or destruction, corruption of data, etc.) with potential consequences on aircraft safety, Operational Reliability or the airline's brand and image.

## Security standards

Airbus ensures that its aircraft are designed, manufactured, produced and delivered in accordance with all applicable security legislation and regulations.

ICAO started addressing aviation security explicitly at the 1963 Tokyo Convention, and continues to develop standards and recommended practices as set out in Annex 17. In 2001, the menace changed in terms of nature and intensity. In the wake of the 9/11 events, the aeronautical community realized that an aircraft can also be used as a weapon of mass destruction.

These incidents generated reactions from the air transportation community actors (aircraft manufacturers, airlines, airports, airworthiness authorities, etc.).

One of the first technical responses provided by the aviation community was a regulation via mandatory requirements such as the reinforced cockpit doors (figure 2).

Since then, many security features are now proposed to operators as options to complement the security of their fleet.

This first step has been followed by a deep reflection on air transportation security in order to anticipate threats and mitigate efficiently the associated risks.

Security is a continuously evolving topic. For example, in December 2006 the EASA asked Airbus to create a dedicated organisation to manage aircraft IS security activities. An aircraft security team has thus been structured and set up for the Type Certification (TC) of the A380. Today, dedicated organisations are composed of specialists and experts with dual competencies in Security and Aircraft design, enabling them to address all security risks from an end-to-end view.

### A 'in-depth defence' approach

The security of the aircraft is based on the 'in-depth security' principle. Instead of having one single barrier, different circled layers of defence are placed (figure 5) between the threats and the aircraft (the aircraft itself being the very last line of defence). The overall security depends on the weakest link of the security chain and the cooperation between all of the actors within this chain.

### International collaboration

All actors in the air transport industry (figure 6) must cooperate to define and orientate the air transportation security in a consistent manner by:

- Sharing on threat definition (attack levels and impacts),
- Sharing on interoperating rules,
- Defining harmonized processes and methods for design, development and operation of security features
- Defining and validating roles and responsibilities.

All aircraft manufacturers collaborate on a non-competitive basis in order to enhance air transportation security.

Airbus has developed its presence and credibility on an international level by proposing means to comply with future regulations. For example, Airbus actively participates to several Standardisation Bodies' committees including but not limited to ECAC, EUROCONTROL-SET, etc., in order to steer and coordinate the development of aircraft security technical standards and rules, and also to promote Airbus' vision on air transportation system security issues.



#### glossary

- ANSP:** Air Navigation Service Provider
- ASFP:** Aircraft Security Focal Points
- ASUP:** Aircraft Security User Panel
- ATM:** Air Traffic Management
- AVSEC:** Aviation Security
- EASA:** European Aviation Safety Agency
- ECAC:** European Civil Aviation Conference
- EUROCAE:** European Organisation for Civil Aviation Equipment
- EUROCONTROL-SET:** European Organisation for the Safety of Air Navigation - Security Evaluation Team
- IATA:** International Air Transport Association
- ICAO:** International Civil Aviation Organisation
- ICCAIA:** International Coordinating Council of Aerospace Industries Associations
- NCI:** National Critical Infrastructures
- SESAR:** Single European Sky ATM Research
- WG:** Working Group

Different circled layers of defence

Figure 5

Threats are mitigated with a multi-barrier approach



**Aircraft Security User Panel (ASUP)**

ASUP is a non-commercial conference that gathers Airbus operators security decision makers as well as key stakeholders of the air transportation community, in order to learn and exchange ideas on the implementation of effective and practical aviation security.

The objectives of this panel are to:

- Inform aircraft operators about current and future Airbus features
- Provide and collect feedback
- Develop a common vision
- Determine and prioritize customer expectations
- Address specific topics linked to future enhancements
- Develop and animate a network of airlines' professionals

Airbus chairs the EUROCAE Working Group number 72 - 'Aeronautical Systems Security', and is a major player of security in SESAR.

Various topics are shared with government security agencies such as the identification and definition of threats (intelligence sharing), validation of aircraft security levels, exchange of expertise, recommendations for new or improved security features, awareness on Airbus aircraft security, etc. All this includes the collaboration with local governmental security agencies on an ad-hoc basis and with selected international law enforcement units.

International collaboration is a key activity in order to set the global picture of the Air Transportation Industry in a common and consistent manner.

**Customer collaboration is key**

The security management of in-service aircraft must rely on a collaborative effort between all stakeholders. Airbus is committed to helping airlines to maintain the security level of aircraft in an evolving threat environment, and aircraft operators also have to comply with their respective regulations. As such, Airbus performs a continuous monitoring of vulnerabilities that may affect aircraft systems and informs aircraft operators immediately if a critical vulnerability is identified.

Airbus meets regularly with its customers' aviation security departments, either in bilateral meetings or during a yearly conference called the Aircraft Security User Panel in order to discuss emerging threats and potential solutions.

**Security actors of the air transport industry**

Figure 6

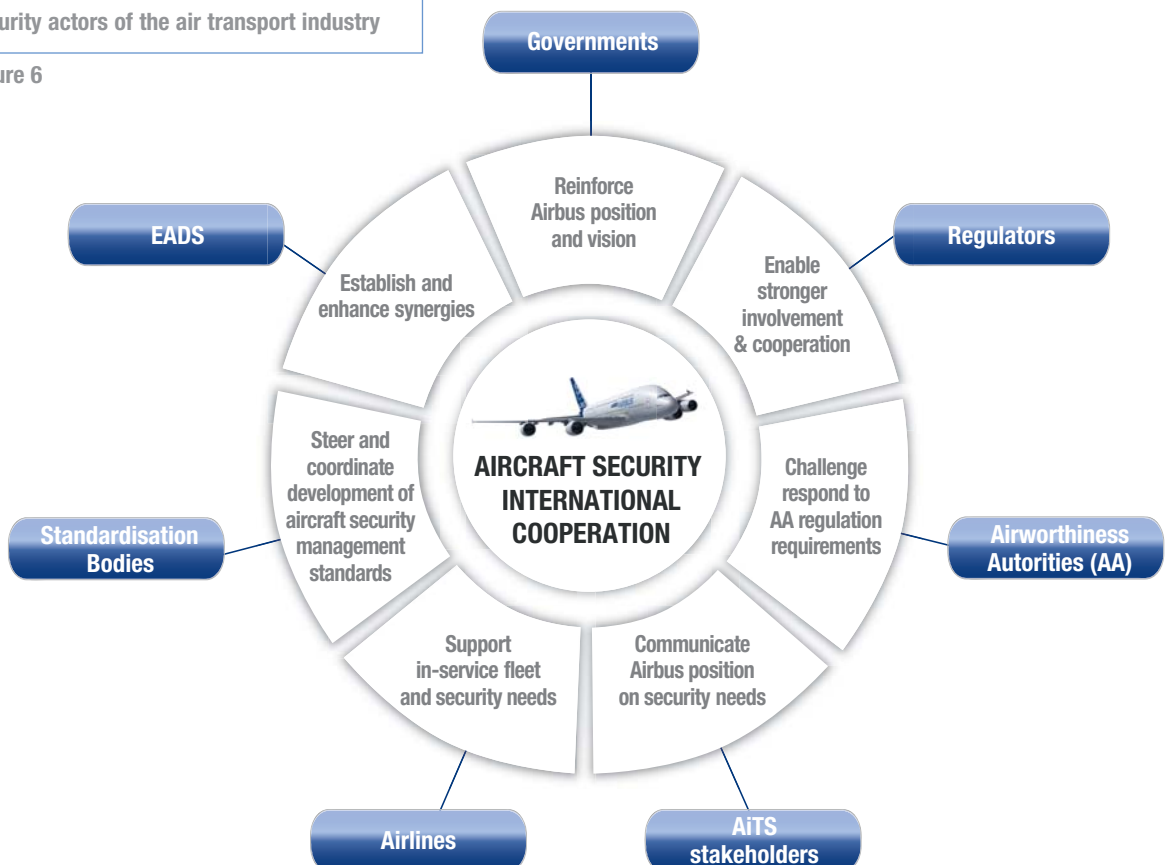

## Risk management

The implementation of new practices in risk management is a major challenge for the air transportation community today. Whilst physical security threat management remains a large activity, the management of information system security is a new and growing objective for all stakeholders. Airbus strongly recommends that all actors in the industry implement a comprehensive and standardized Security Management System covering both physical and cyber security.

Airbus has developed a comprehensive and dedicated aircraft Security Management System based on recognized international ISO standards, and also offers specific solutions for implementation, enhancing the performance of operational physical and cyber security by providing:

- Expertise in the management of aviation security risks,
- Support for the implementation of security procedures,
- Assistance in getting local operational approval from airworthiness authorities.



### information

Airbus provides a security handbook to operators that collects security procedures to complement the aircraft's technical security measures for specific security risks. Ad-hoc security procedures are issued via dedicated information bulletins. Contact: [ac\\_sec@airbus.com](mailto:ac_sec@airbus.com)



#### CONTACT DETAILS

**Pascal ANDREI**  
Head of Aircraft Security  
Airbus S.A.S.  
Tel: +33 (0)5 67 19 18 07  
[pascal.andrei@airbus.com](mailto:pascal.andrei@airbus.com)

**Gernot LADSTAETTER**  
Head of Aircraft In-Service Security  
Airbus S.A.S.  
Tel: +49 (0)-40 7436 2682  
[gernot.ladstaetter@airbus.com](mailto:gernot.ladstaetter@airbus.com)

**Isabelle DUFEU**  
Aircraft Security - Special Project Manager  
Airbus S.A.S.  
Tel: +33 (0)5 62 11 07 60  
[isabelle.dufeu@airbus.com](mailto:isabelle.dufeu@airbus.com)

## Conclusion

In the future, security and the associated risk management systems will be confronted with increasingly complex, dynamic and smart threats targeting multiple aspects such as people, aircraft systems, operations or air traffic management systems.

In order to mitigate or eliminate the risk of such threats, the aircraft security architecture and capabilities - technical and organisational - as provided by Airbus enable operators to benefit from a seamless and dedicated risk management system. Airbus aircraft designs incorporate integrated security features that need to be maintained

throughout their lifecycle and the Airbus security management system.

Airbus also invests in Research & Technology, in order to continuously provide up to date tailored solutions against future threats emerging from a constantly changing environment.

The global security of the aircraft also requires international collaboration between all the actors of the air transportation chain, and Airbus was the first to provide a dedicated forum for its operators called the Aircraft Security User Panel. Despite all the advances in terms of layered protection, the aircraft is and will always remain the last line of defence.

After the wehee-Taxi, the moo-Taxi, it is now time for the eTaxi.

- "But what on Earth could that be? What does the "e" stand for and does it have anything to do with an elephant?"
- No, you're cold.
- An eagle?
- Nice try, but try again.
- An ermine?
- Come on!
- An electric eel?
- Close, very close."

The 'e' stands for electric. The draught animals can leave for a deserved retirement. Thanks to eTaxi, taxiing on runways will be electrically operated saving considerable fuel loads and contributing to a reduction of CO<sub>2</sub> emissions, as explained in this FAST magazine (article eTaxi: Page 2-10).



Messerschmitt Me 163 Komet

Pictures courtesy of EADS Corporate Heritage

Fokker Dr.I



All the FAST magazines

are available free-of-access on: [WWW.AIRBUS.COM/SUPPORT/PUBLICATIONS](http://WWW.AIRBUS.COM/SUPPORT/PUBLICATIONS)



We hope that you have enjoyed yourselves in answering this quiz and thank you again for your encouragements and interest in FAST magazines!

The 50 winners will be drawn and will soon receive their Airbus giveaway prize.

## Answers to the FAST 50 magazine quiz

1) When was the first FAST magazine published?

(clue in FAST 1)

- A.  1979
- B.  1983
- C.  1989
- D.  1995

2) What is the wing span of an A310? (clue in FAST 5)

- A.  41.5 m
- B.  42.1 m
- C.  43.9 m
- D.  44.6 m

3) What is the advantage of the Airbus Fly-By-Wire system? (clue in FAST 9)

- A.  It saves weight
- B.  It reduces complexity
- C.  It increases the aircraft reliability
- D.  All of the above answers are correct

4) I am an engineering tool used to design, integrate, optimize and validate vital aircraft systems such as the Electrical Generation, Hydraulic Generation, Flight Control System, Auto-Flight System, Warning System (ECAM) and the Centralized Fault and Maintenance System. What am I? (clue in FAST 24)

- A.  The Test Bed
- B.  The Iron Bird
- C.  The Flying Prototype
- D.  The Virtual Fly Test

5) Airbus received acceptance of the A380 Maintenance Review Board Report (MRBR) from the European Aviation Safety Agency (EASA) on which date?

(clue in FAST 38)

- A.  23 December 2005
- B.  17 September 2006
- C.  12 November 2007
- D.  4 July 2008

6) Which system on Airbus aircraft provides protection against fuel tank fire and explosion? (clue in FAST 44)

- A.  Fuel Tank Extinguishing System (FTES)
- B.  Fire and Explosion Prevention System (FEPS)
- C.  Fuel Tank Inerting System (FTIS)
- D.  Fuel Valve Bypass System (FVBS)

7) What happened on 1 February, 2008? (clue in FAST 46)

- A.  Airbus completed a flight non-stop around the world with an A380
- B.  Airbus completed the world's first ever flight by a commercial jet (A380) using synthetic liquid jet-fuel made from natural gas (GTL)
- C.  Airbus launched its new A350XWB programme
- D.  Airbus sold its 5,000th A320 Family aircraft

8) What is the name of the tool especially developed by the Airbus Structures Test Domain for the A320 impact calibration campaign, which is now used for the impact threat evaluation for the A350XWB composite fuselage?

(clue in FAST 48)

- A.  MICKEY
- B.  RATATOUILLE
- C.  YOGI
- D.  GUISMOT

9) The radio altimeter is used to provide an accurate height above ground level when the aircraft is between?

(clue in FAST 49)

- A.  0 and 1,000 feet
- B.  0 and 2,000 feet
- C.  0 and 2,500 feet
- D.  0 and 3,000 feet

10) What is called the innovative cabin option for the A320 Family aircraft? (clue in FAST 50)

- A.  Space-Flex
- B.  Spice-Flex
- C.  Space-Flux
- D.  Spice-Flux

# LAG

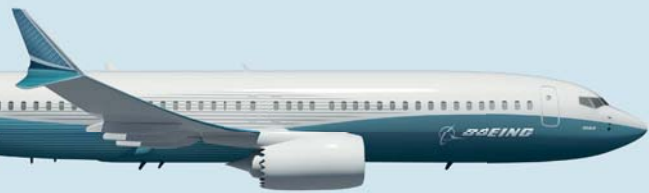

A derivative of a 1960's design (even if it has been amended from time to time), it's no wonder the 737 MAX is suffering from jet lag.

The 737 MAX will probably be the last non fly-by-wire commercial aircraft the industry will ever see. An aircraft family unto itself with low commonality with other Boeing products.

It has a narrow fuselage which offers comfort based on a 1960's standard, pivoting passenger doors, 17 inch seat width and no wide-aisle option, required for today's fast turn-around times.

It also has no containerised cargo, small cumbersome inward opening doors, and constrained engine optimisation possibilities due to its 1960's undercarriage design. You don't even get a choice of engines.

By the time the 737 MAX is expected to arrive in 2017, it will be the 50<sup>th</sup> anniversary of the 737 first flight.

The 737 MAX. Based on a 1960's design. A true case of jet lag!



# JET



There are some very good reasons why our A320neo Family is leading the single-aisle jet market and is meeting all of today's modern airline needs.

Innovative design, and advanced fly-by-wire with renowned Airbus commonality results in superior fuel efficiency, reduced noise and less environmental impact, alongside low maintenance costs and the lowest operating costs per seat.

The A320 Family is the most spacious single-aisle family, offering a wider cabin, wider aisles, more overhead storage and greater comfort, even in economy. It also offers unique cargo capabilities to carry standard containers.

The A320neo Family has uncompromising engine efficiency. It has the largest fan diameter and highest by-pass ratio. Combined with our proven Sharklet technology, this means at least 15% less fuel burn than today's A320 Family, and less fuel burn per seat than the so called 'firm concept' 737 MAX. So it appears that size does matter.

It is no surprise that the NEO is the fastest selling aircraft in the history of civil aviation. With more than 1,500 orders in less than two years the A320neo Family has captured 60% of its market.

