

Airbus technical magazine

January 2014

#53

FAST

Flight Airworthiness Support Technology

Your Airbus technical magazine is now on tablet



iOS (iPad) & Android

Airbus technical magazine #53

FAST

Flight Airworthiness Support Technology

Publisher: Bruno PIQUET

Editor: Lucas BLUMENFELD

Design: Daren BIRCHALL

Cover: Electrical Structure Network

Photo by: Master Films / J-B ACCARIEZ

Printer: Amadio

Authorisation for reprinting FAST magazine articles should be requested from the editor

Tel: +33 (0)5 61 93 43 88

Fax: +33 (0)5 61 93 47 73

e-mail: fast.magazine@airbus.com

FAST magazine is available on internet
www.airbus.com/support/publications

and on tablets

ISSN 1293-5476



© AIRBUS 2014

All rights reserved. Proprietary document

By taking delivery of this Magazine (hereafter 'Magazine'), you accept on behalf of your company to comply with the following. No other property rights are granted by the delivery of this Magazine than the right to read it, for the sole purpose of information. This Magazine, its content, illustrations and photos shall not be modified nor reproduced without prior written consent of Airbus. This Magazine and the materials it contains shall not, in whole or in part, be sold, rented, or licensed to any third party subject to payment or not. This Magazine may contain market-sensitive or other information that is correct at the time of going to press. This information involves a number of factors which could change over time, affecting the true public representation. Airbus assumes no obligation to update any information contained in this document or with respect to the information described herein. The statements made herein do not constitute an offer or form part of any contract. They are based on Airbus information and are expressed in good faith but no warranty or representation is given as to their accuracy. When additional information is required, Airbus can be contacted to provide further details. Airbus shall assume no liability for any damage in connection with the use of this Magazine and the materials it contains, even if Airbus has been advised of the likelihood of such damages. This licence is governed by French law and exclusive jurisdiction is given to the courts and tribunals of Toulouse (France) without prejudice to the right of Airbus to bring proceedings for infringement of copyright or any other intellectual property right in any other court of competent jurisdiction. Airbus, its logo, A300, A310, A318, A319, A320, A321, A330, A340, A350 XWB, A380 and A400M are registered trademarks.

Photo copyright Airbus
Photo credits: Airbus Photographic Library, Airbus Flight Test Photo Lab, EADS Corporate Heritage, Master Films, EXM company, Eurocontrol, SESAR J.U., Johann Helgason



Ground lightning protection

04

Handling Qualities Analysis

10

A350 XWB Electrical Structure Network

20

Towards a high European air traffic demand

26

Volcanic eruptions: Ashes to AVOID

32

FAST from the past

38

We've got it covered

39



Where you see these icons, videos or slide shows are available on the FAST digital app.

Ground lightning protection

An adapter for Ground Power Units

A380 operators reported incidents of lightning strikes while parked on the apron at Singapore's Changi international airport. These strikes were principally attracted due to a combination of the airport's surface, the local climate and the height of the aircraft. In just seven months, Airbus' Operational Reliability Task Force developed a dedicated Lighting Protection Unit (LPU), which is now undergoing in-service evaluation with our customers.

The context

The equatorial climate is often characterized by heavy heat and regular precipitations throughout the year. This leads to strong, electrically charged, thunder storms particularly in the monsoon season.

The height of the A380's vertical stabilizer coupled with the structure of the apron's surface increases the possibility that the aircraft may be struck, directly or indirectly, during the Turn-Around-Time (TAT).



Article by

Frédéric FORGET

A380 Work Package Leader

AIRBUS

frederic.f.forget@airbus.com

Airbus recommends disconnecting the Ground Power Unit from the aircraft during storms to avoid damage to electrical components. In practice, during the Turn-Around-Time, the ground power supply needs to remain connected to continue supplying the aircraft with power. It is under these circumstances that the aircraft is particularly vulnerable.

An aircraft is designed as a Faraday cage (see side box), which is a structure that blocks external static and non-static electric fields, therefore avoiding damage by lightning strikes. However, when an aircraft is connected to a ground power supply, the connecting cable provides a direct route to the aircraft's systems.

By electromagnetic induction (see side box) a lightning strike can damage the Primary Electrical Power Distribution Centre (PEPDC) and/or the Generator & Ground Power Control Unit (GGPCU). This kind of damage would result in an Aircraft On Ground (AOG), requiring costly repairs taking up to six days to complete.



Fig. 1

Working 'like lightning' to develop a solution

Operators requested that Airbus quickly find a solution to protect ground power connected to the A380 in these particular conditions. In December 2012 during Airbus' A380 symposium at Dubai (United Arab Emirates), the A380 Chief Engineer (Marc GUINOT) committed to resolving the issue before the end of June 2013.

Faraday cage/shield

A Faraday cage (or shield) is an enclosure formed by conducting material or by a mesh of such material.

Such an enclosure blocks external static and non-static electric fields by channelling electricity through the mesh, providing constant voltage on all sides of the enclosure. Since the difference in voltage is the measure of electrical potential, no current flows through the space.

A Faraday cage operates because an external static electrical field causes the electric charges within the cage's conducting material to be distributed such that they cancel the field's effect in the cage's interior. This phenomenon is used, for example, to protect electronic equipment from lightning strikes and electrostatic discharges.

Electromagnetic induction

Induced voltage is an electric potential created by an electric field, magnetic field or a current. This is conducted to the ground by an ionized section of the atmosphere, and can easily induce voltages in conductive material such as electrical cabling.

2013 / 2012	November	Design office put in the loop	Design Office development	Design Office project management
	December	Airbus Chief Engineer commits to airlines Plug interface found Lightning protection requirements		
	January	LPU development launched with Leach International First specific draft		
	February	LPU design frozen Plug integration tests on aircraft		
	March	Plug design frozen		
	April May	Integration and tests		
	June	Parts delivery to airlines		
July	In-service evaluation			

Frédéric FORGET, from Airbus' Electrical and Optical Standard parts' department took the lead and was tasked with quickly finding a solution - a big challenge knowing that this type of project usually takes 18 to 24 months.

He set up a dedicated task force with the lightning strikes' and electrical network specialists. Due to the time constraints of validating changes to the aircraft itself, the task force focused on providing external protection. The idea was to develop an external protection tool for Ground Support Equipment (GSE). The decision was then taken to use the same technology already existing inside the aircraft to protect the power feeder: the Lightning Protection Unit (LPU), but optimized for this specific application.

An LPU embedded solution

Knowing that it would also have taken too much time to develop a specific interface, the team decided to embed the LPU into an existing adaptor plug (Fig. 2) manufactured by TDA Lefebure, that would connect between the aircraft and the Ground Power Unit.

In parallel, the lightning strike specialists defined the most realistic threat in order to dimension the LPU protection. The lightning threat model used covered more than 90% of potential cases. The induced voltage generated by the lightning's indirect effect is 1,600 volts, or 14 times the aircraft's normal network voltage.

The LPU uses transient voltage suppression diodes (Fig. 3) to filter the voltage spike out through the ground during the lightning strike. The residual voltage after the LPU shall not exceed the network voltage spike envelope defined in figure 5, keeping the power entering the aircraft close to 115 volts.

The main functions of the LPU are to protect the electrical power line in case of lightning strikes and not damage and/or perturb the power signal during, and after, normal/abnormal transient voltage.

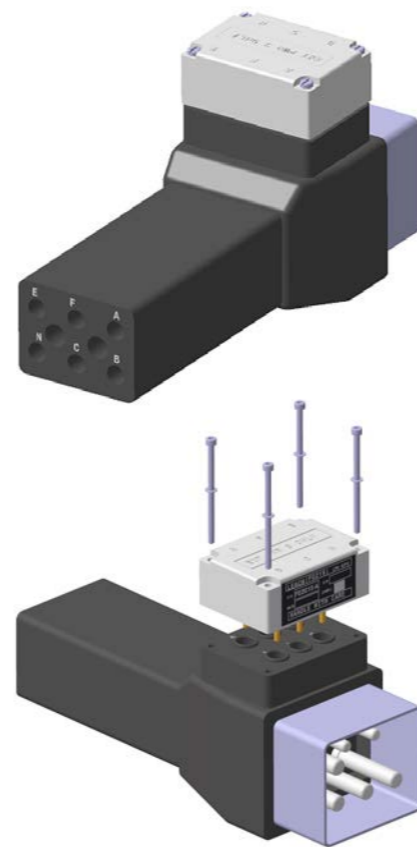
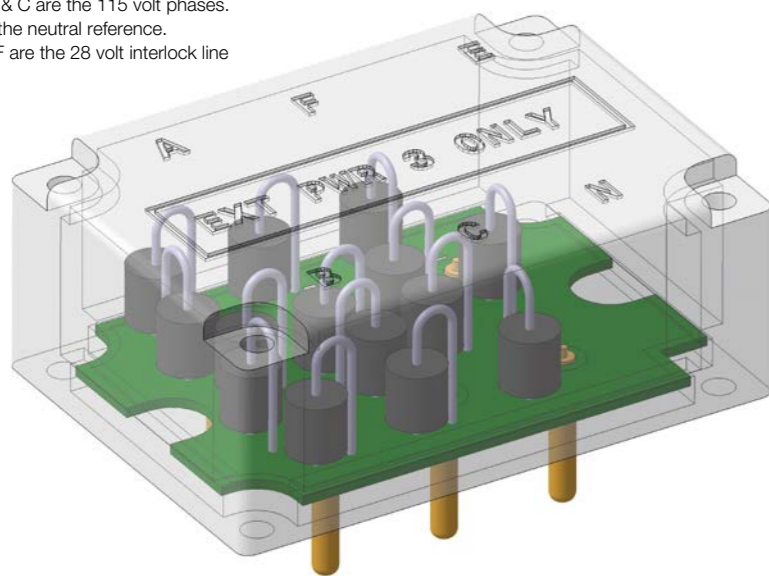

Fig. 2: the modified adaptor plug and the LPU embedded on it

Fig. 3: transient voltage suppression diodes inside the LPU:
A, B & C are the 115 volt phases.
N is the neutral reference.
E & F are the 28 volt interlock line



Airbus approached Leach International, suppliers of the A380's internal LPU, to redesign and resize it to handle the threat. The plug manufacturers redesigned it to interface with the LPU. An integration test on the aircraft was done with a plug, in order to check the pin retention and if the plug and the structure did not clash. In parallel, Airbus used Catia DMU (Digital Mock-Up) software to visualize its integration.

Due to the ground service connections' typology, it was necessary to design two assembly configurations of the LPU plug (Fig. 4). Each A380 aircraft needs a set of four plugs, the configuration 'A' plug is only used for the external 'power 3' receptacle and the configuration 'B' for the external power plugs '1, 2 and 4' (Fig. 6 & 7). For the in-service evaluation six sets of four plugs were produced.



Fig. 4

DO160

The DO160 is an official document which defines a series of minimum standard environmental test conditions (categories) and applicable test procedures for airborne equipment. The purpose of these tests is to provide a laboratory means of determining the performance characteristics of airborne equipment. These environmental conditions are representative of those which may be encountered in airborne operation of the equipment.

The DO160 provides the test methods and procedures to verify the capability of equipment to withstand transient voltages which are intended to represent the induced effects of lightning. The most relevant waveform for our application is the voltage waveform 2.

Voltage spike envelope shows the acceptable voltage input.

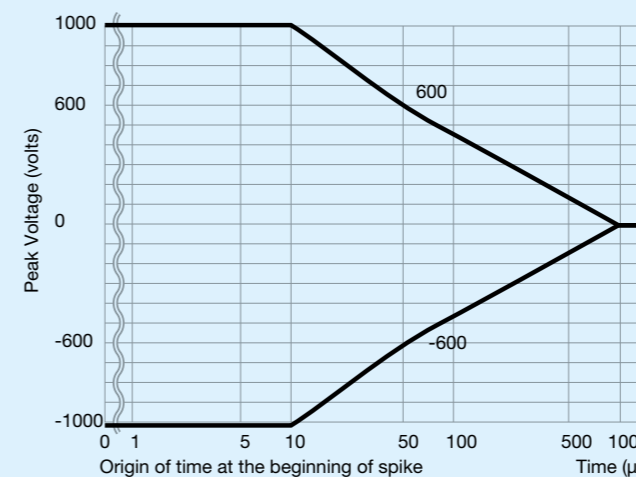

Fig. 5

Voltage waveform 2

This illustration gives the "shape" of the lightning threat applied to LPU plug pins.

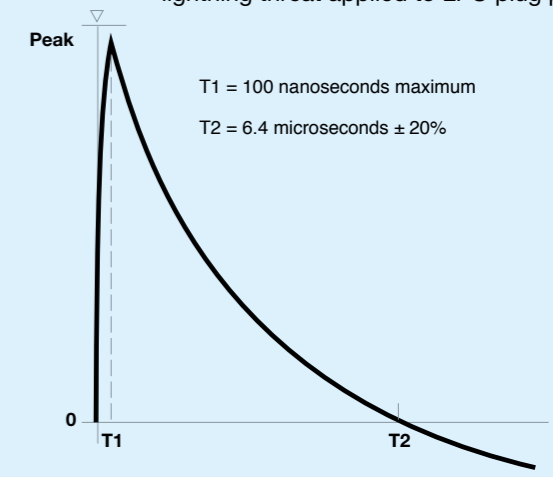
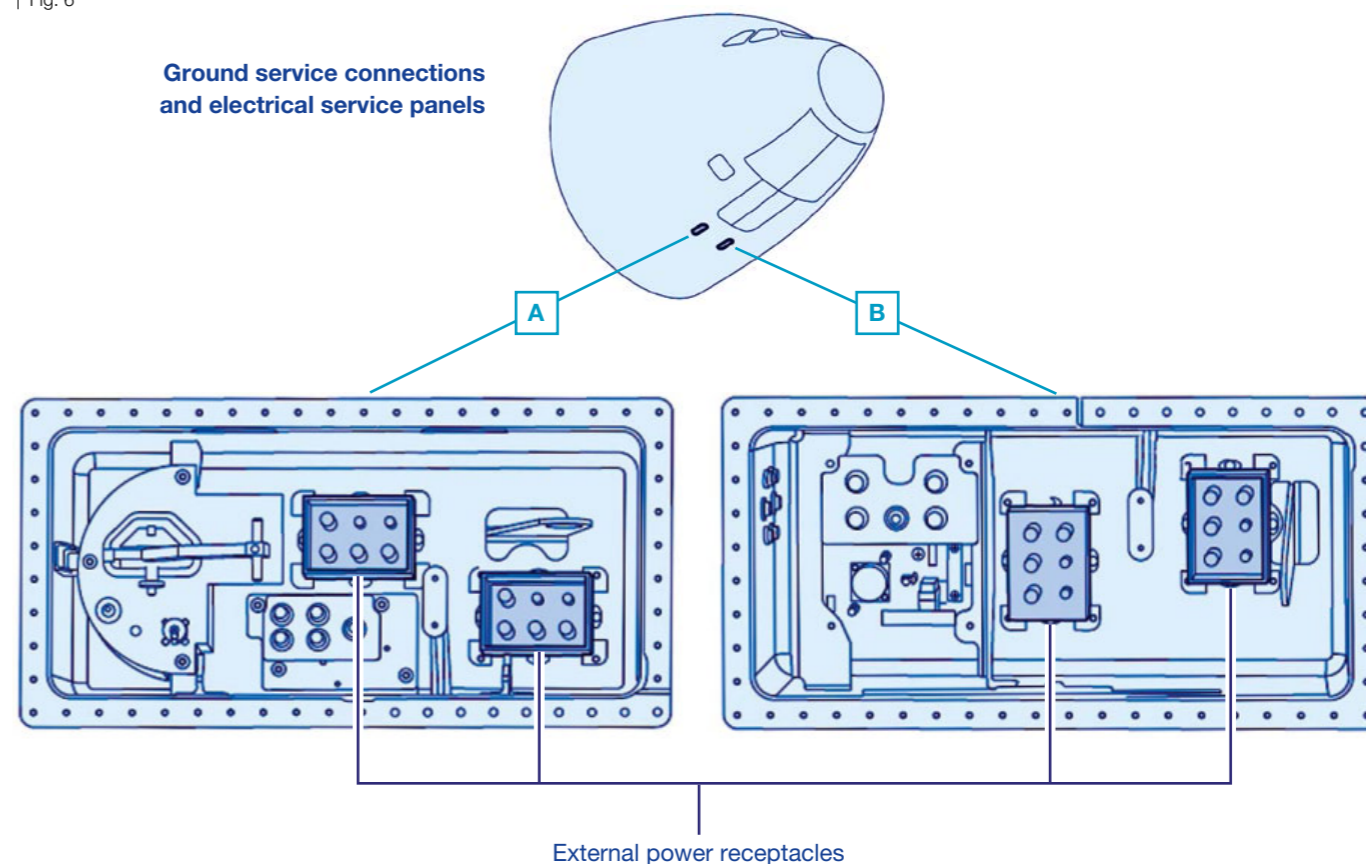

Fig. 6

Ground service connections and electrical service panels



External power receptacles



All aircraft are susceptible to lightning

Airbus built a mock-up in their lightning strike laboratory at Blagnac (France) to test the lightning strike protection system. These tests are performed for every Airbus fleet programme as shown here for the A350 XWB.

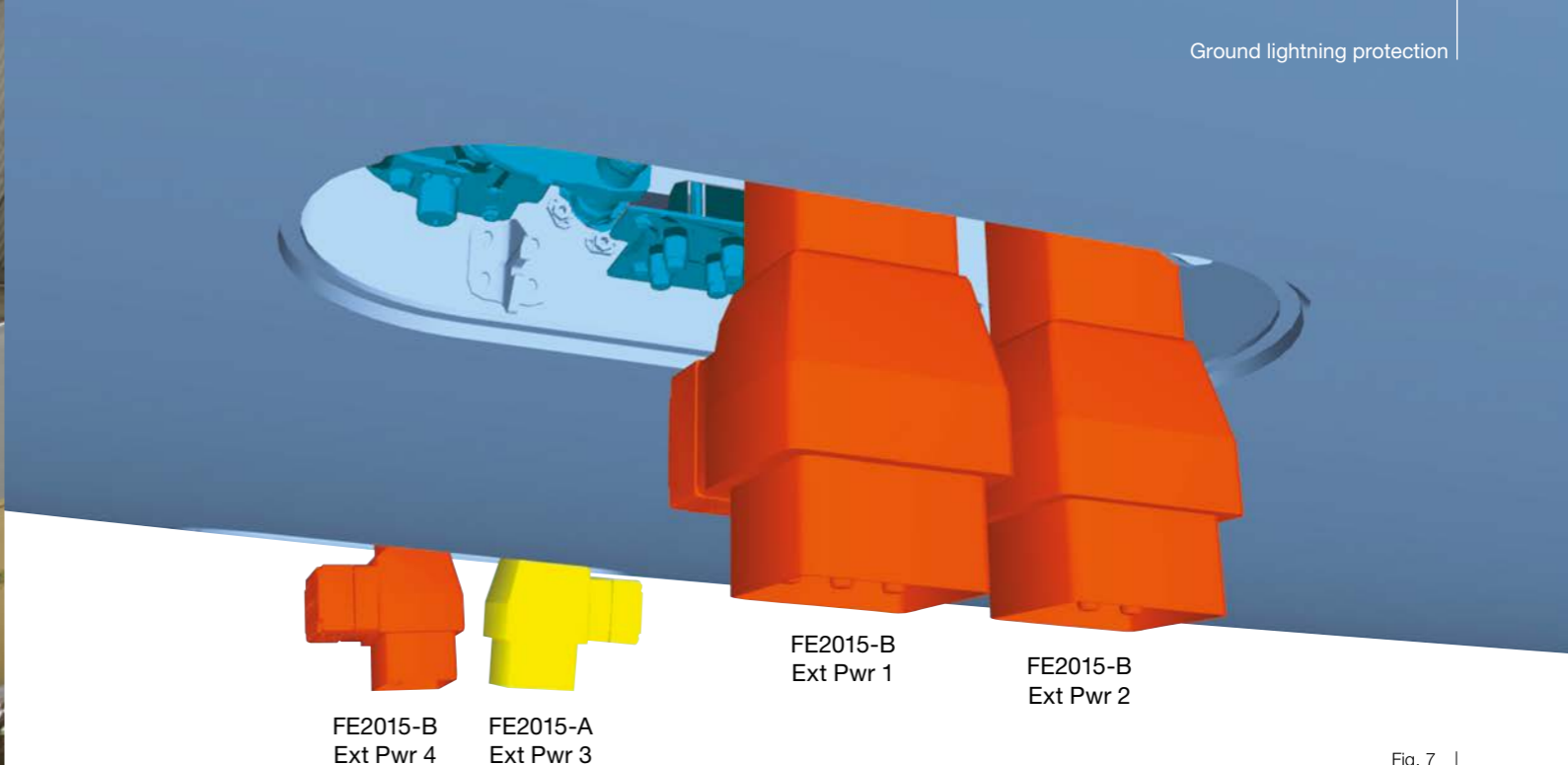

Fig. 7

The configuration 'A' plug is only used for the external 'power 3' due to the orientation of the receptacle and the configuration 'B' for the external power plugs '1, 2 and 4'

On the first prototype, Airbus conducted a programme of Validation and Verification (V&V) tests, as well as electrical and lightning strike tests, using a model at Airbus' lightning laboratory facility. All qualification tests were carried out at Leach's laboratory. The prototype passed all the requirements and Airbus qualified the solution.



CONCLUSION

Some regions around the world experience severe climate conditions and lightning strikes may cause heavy damage to an aircraft. Airbus developed a connecting plug with lightning protection for the A380, to be installed between the ground cart power supply and the aircraft's power receptacle. These new adaptor plugs, developed in seven months and delivered at the end of June 2013, deviate the eventual electric surge to the ground and the airlines are now conducting a six-month in-service evaluation to validate our laboratory findings. Airbus also provided a technical report which explains the implementation of the Lightning Protection Unit (LPU) for the A380 double-deck Ground Power Unit connection.

Complementary LPU plug installation/removal AMM tasks

Installation:

- AMM task 24-41-00-861-801-A
- AMM task 24-41-00-861-801-A02
- AMM task 24-41-00-861-803-A
- AMM task 24-41-00-861-804-A
- AMM task 24-42-00-861-801-A

Removal:

- AMM task 24-41-00-862-801-A
- AMM task 24-41-00-862-801-A02
- AMM task 24-41-00-862-803-A
- AMM task 24-41-00-862-804-A
- AMM task 24-42-00-862-801-A

Handling Qualities Analysis

Specific in-service events analysis



Following an in-service incident, airlines usually contact Airbus' engineering support to be provided with guidelines and/or recommendations to release the aircraft back into service (inspections, tests, etc.), with a clear objective to limit as much as possible the impact on future operations.

Beyond technical assistance, Airbus offers to help operators better understand the event through a detailed analysis, mainly based on raw data extracted from the Flight Data Recorder.

This Airbus activity, known as "Handling Qualities Analysis" (HQA), consists of analysing specific in-service events. It is carried out in close collaboration with several Airbus departments such as Flight & Integration Test Centre, Design Office, Flight Operations, Flight Safety and other relevant Airbus Customer Services engineering departments.

Airbus contributes to the safety of Airbus' aircraft by monitoring and analysing in-service events reported by airlines.

The Handling Qualities' activity supports globally Airbus' Product Safety Process (PSP) and contributes to the continuous improvement of our products.

Article by
Vincent MILLET

Senior Engineer
Handling Qualities Product Leader
AIRBUS
vincent.millet@airbus.com

Damage on an Auxiliary Power Unit drain mast following a tail strike event



When is an HQA report issued?

A Handling Qualities Analysis (HQA) report issued by Airbus is provided to customers following occurrences such as:

- Hard landing leading to additional maintenance actions further to AMM (Aircraft Maintenance Manual) findings or loads' exceedance,
- Tail strike,
- Runway excursion,
- Turbulence with serious injuries and/or excessive flight parameter deviations,
- Significant over-speed event leading to maintenance inspection as per AMM requirements,
- Inappropriate aircraft handling:
 - Unstable approach as per Flight Crew Operating Manual (FCOM),
 - Abnormal landing,
 - Significant bounce.
- Flight out of the aircraft's certified envelope,
- Recurrent event identified by Airbus' Product Safety Process.

Unexpected or major events may require structure inspections.

The major events entering the HQA scope and their associated AMM tasks:

- Inspection after overweight/hard landing: AMM 05-51-11
- Flight in turbulence or VMO (Maximum Operating Speed of an aircraft) exceedance: AMM 05-51-17
- Tail strike: AMM 05-51-21
- Runway excursion: AMM 05-51-24

As a general rule, any event requiring structure inspections is referenced in any AMM chapter 05-51-xx.

In the case of in-service events (not covered in the HQA occurrence list) on which an operator would like dedicated Airbus analysis for specific happenings, an HQA may be carried out on a case-by-case basis.

Objectives of the HQA report

Independently of the aircraft's release to service, the main customer's concern after an in-service event is to understand both the technical and operational causes, in order to prevent a re-occurrence.

In-service events are recorded through the Flight Data Analysis (FDA) system and directly reported to Airbus for investigations.

As a consequence and to help minimizing re-occurrences (and their associated costs), Airbus performs a complete run-through of an in-service event, extracting the scenario from the Flight Data Recording (FDR) decoding, to explain the contributing factors.

The HQA, based on the FDR raw data readout, is carried out in parallel with the load analysis generally required for structure inspection purposes. The aircraft's release to service is out of the HQA activity's scope.

The HQA report highlights the contributing factors of an event by analysing the aircraft's systems behaviour and the aircraft's response versus the pilot's input.

To make it easier, the analysis gathers references of available operational Airbus aircraft documentation, as well as design enhancements whenever applicable.

If necessary, to better understand an operational event, the analysis could focus on the logic of a particular system operating during the event (i.e. Ground spoilers' automatic extension at touchdown).

Main objectives:

- Understand an event and its origin.
- Provide information on operational best practices to avoid re-occurrence.
- Monitor the fleet and systems' design consistency.



Handling Qualities Analysis meeting

Operational information can come either from operational manuals (Flight Crew Operating Manual - FCOM, Flight Crew Training Manual - FCTM, Aircraft Flight Manual - AFM, etc.) or from Airbus' general documentation (Flight Operations' Briefing Notes, Getting to Grips with..., etc.)

With the HQA report in hand, the operator has a synthetic document to take appropriate decisions or cascade down the relevant information.

On Airbus' side, the airline's feedback is key to monitor Airbus' in-service fleet and to ensure continued airworthiness, while enhancing and developing new systems and/or procedures to continuously fit operational constraints.

Overview of conditions for the extension of ground spoilers

(Shown here for A340-500/600 aircraft)

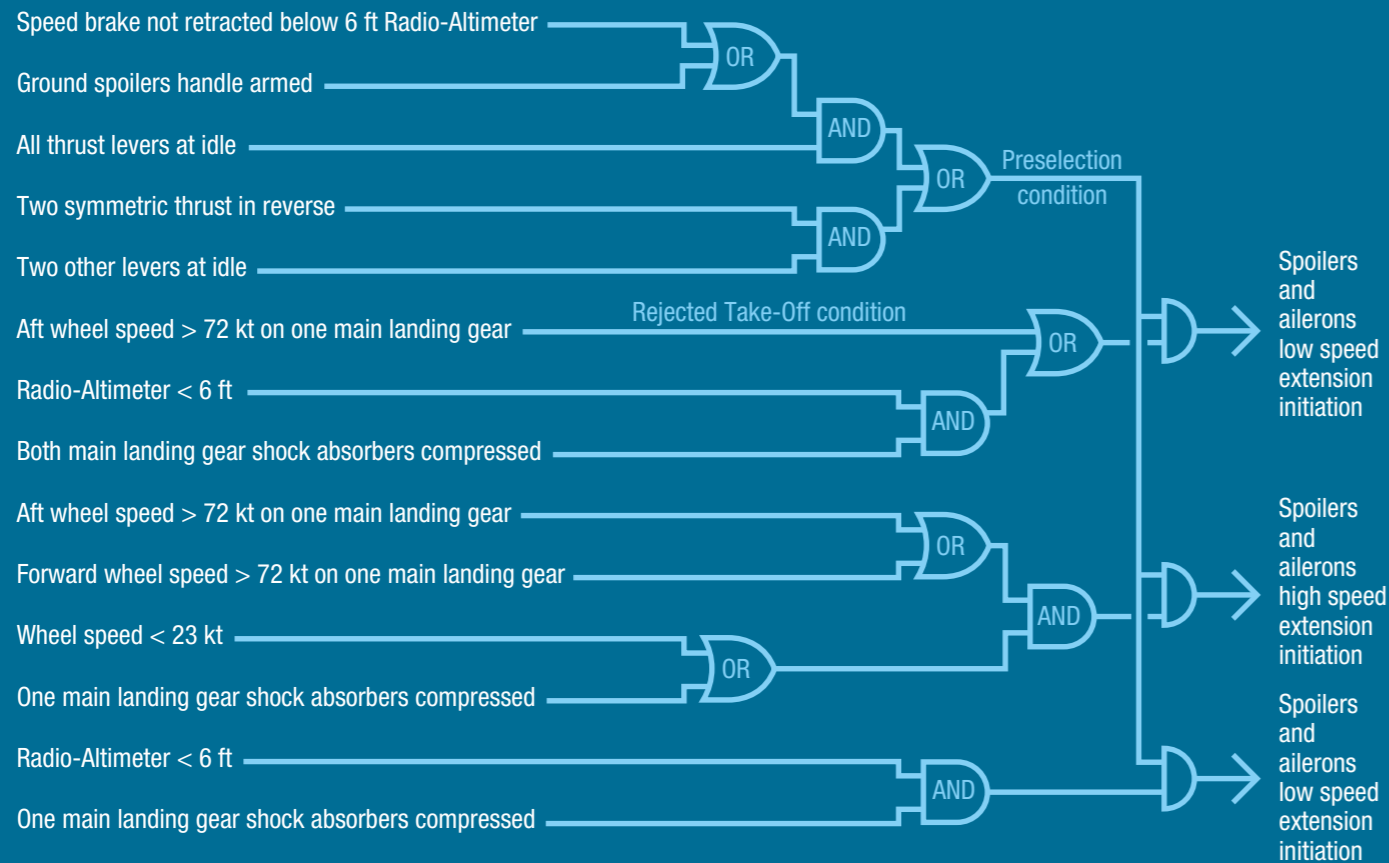

Handling qualities reports in 2012

Quantities and percentages

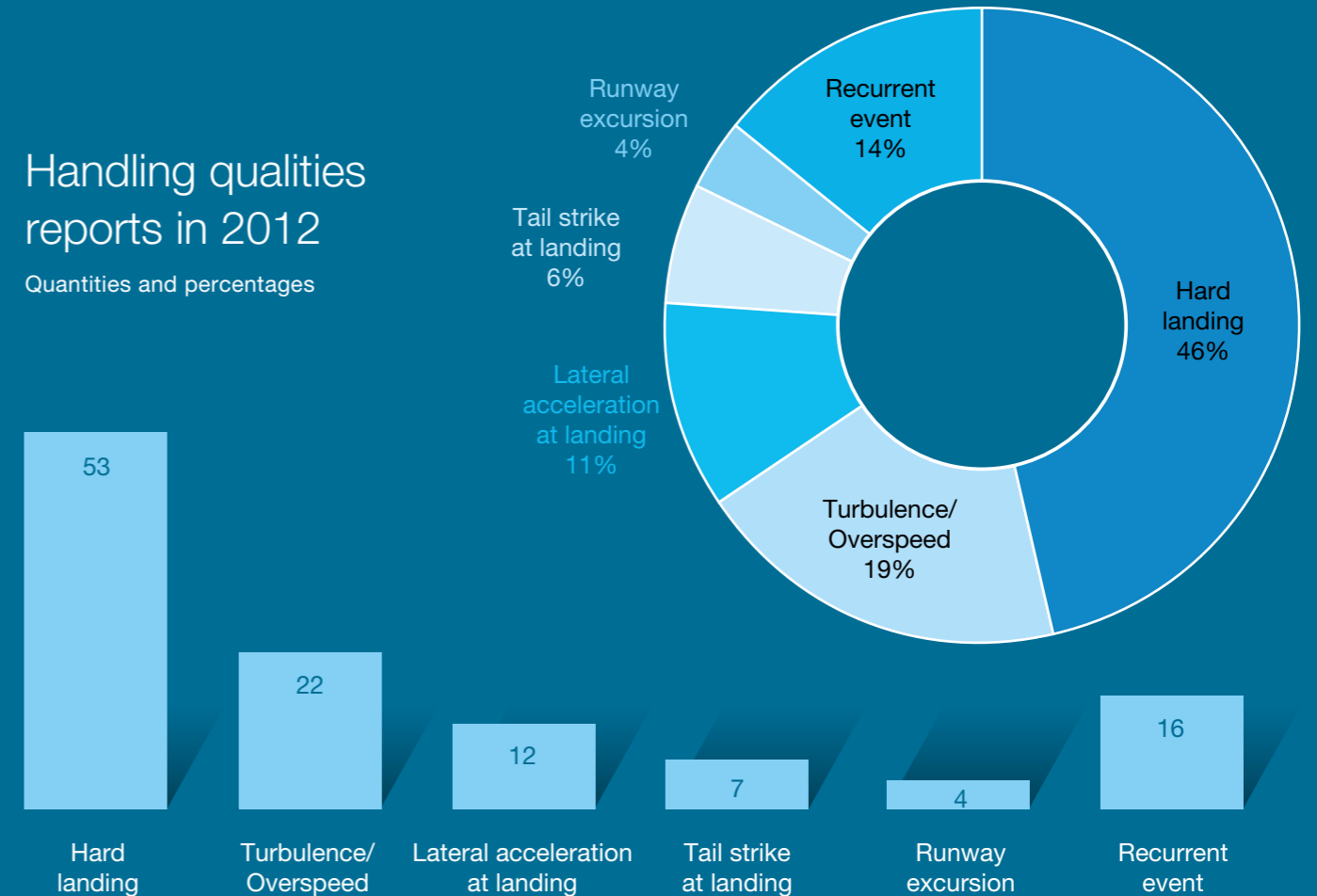

Raw data decoding

Using a specific Airbus tool, raw flight data is displayed as graphic charts for the event's analysis. Recorded flight data in this format allows a detailed analysis of aircraft behaviour and aircraft systems at the time of the event. This example highlights some of the relevant parameters used to analyse a hard landing event of an A320 aircraft.

DA = Degree Angle
 FT = Feet
 G = acceleration value
 KT = Knots

FLARE INITIATION
 TOUCHDOWN

FLARE INITIATION
 TOUCHDOWN

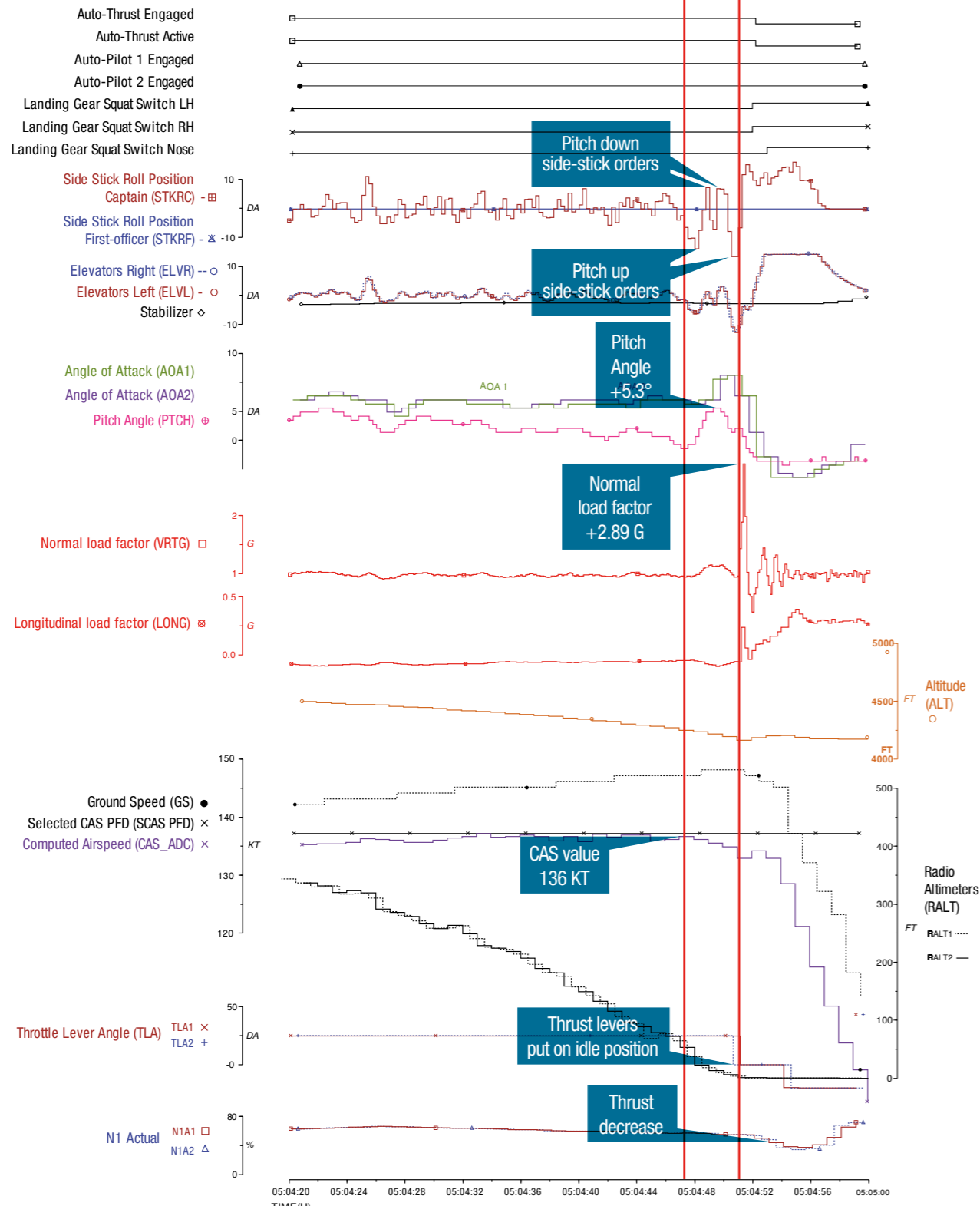

Aircraft: A320
 Centre of Gravity (%) 32.16
 Weight (LBS) 138160
 Weight (KG) 62656
APPROACH (LONGITUDINAL AXIS)

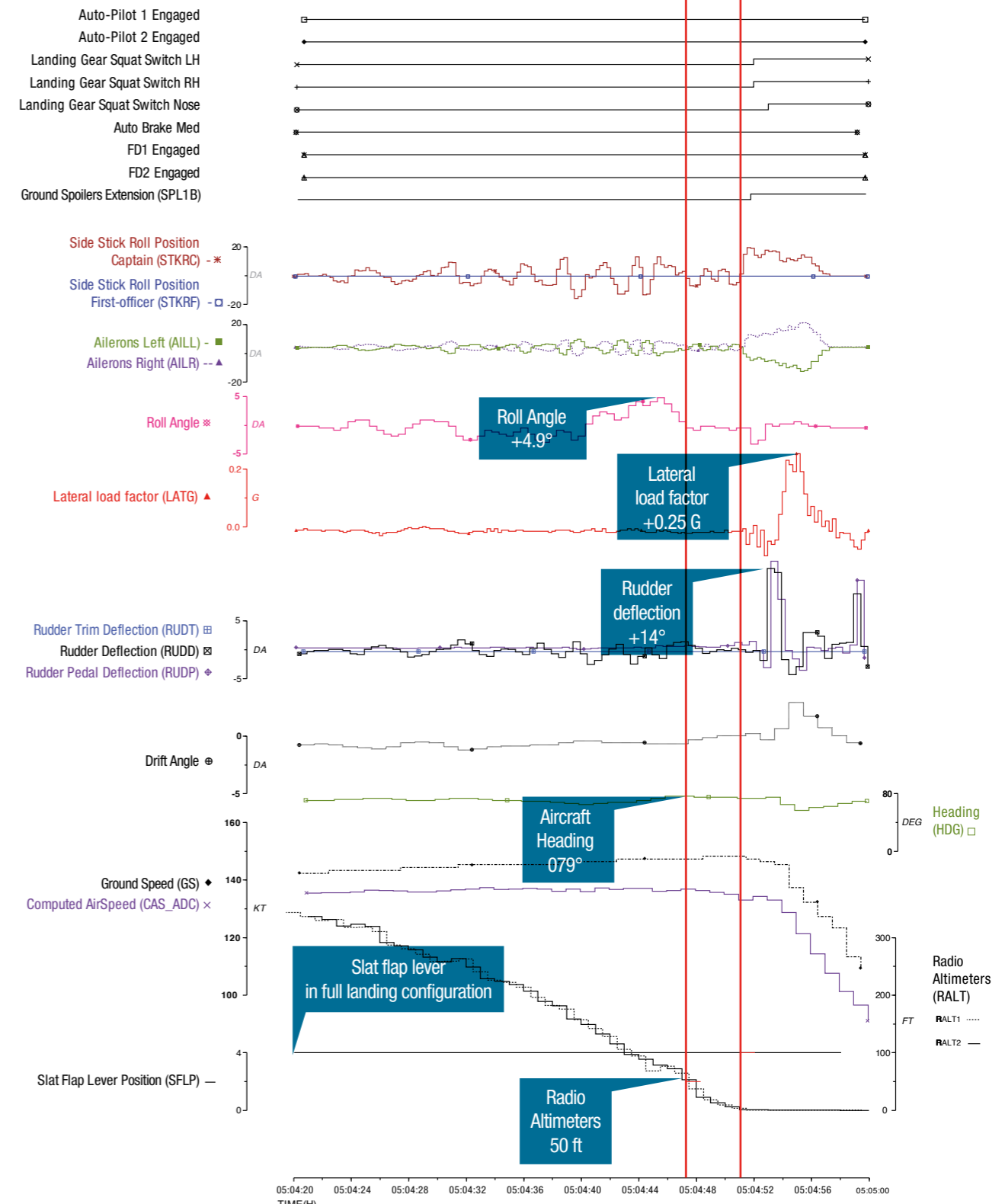

Aircraft: A320
 Centre of Gravity (%) 32.16
 Weight (LBS) 138160
 Weight (KG) 62656
APPROACH (LATERAL AXIS)



MANDATORY

Digital/Solid State Flight Data Recorder

- In-service event analysis
- Frozen dataframe
- Crash protected

OPTIONAL

Quick Access Recorder

- Copy of Flight Data Recorder
- Easy access

Digital Aids Recorder / Smart Access Recorder

- Maintenance and fleet monitoring
- Customized dataframe

Once the data has been retrieved from the aircraft, it must be sent to Airbus either by the airlines field representative or directly using Airbus' File Transfer Service Plus (FTS+) on AirbusWorld (<https://ftsplus.airbus.com>).

What data is used?

For absolute accuracy, Airbus only analyses raw data, either from the Flight Data Recorder (FDR) or the maintenance recorder (QAR). In exceptional circumstances, raw data from the Digital Access Recorder (DAR) may be used, providing that the corresponding DAR database is supplied at the same time.

Airbus' WISE (World In-Service Experience) solution (ref: EngOps-16063) provides a list of usable data formats (file extensions) and a list of AMM tasks relative to the procedure of flight raw data recovery.

GLOSSARY

FDR (Flight Data Recorder): Mandatory device that permanently works from the first engine start until the end of the flight. Thanks to a large memory capacity, it records many flight hours and numerous flight parameters.

QAR (Quick Access Recorder): Copy of the FDR and thus records the same data. It allows a quick and easy recovery of the raw data recorded in FDR. Only raw data is used for the event analysis.

DAR (Digital Access Recorder): Mostly maintenance and fleet monitoring oriented and therefore should not be used for event analysis as the data frame can be customized by the operators. As a consequence some useful parameters could be missing to perform a detailed HQA.

PFR (Post Flight Report): Lists and displays after landing the ECAM (Electronic Centralized Aircraft Monitor) warnings and system faults that occurred during the flight.

ACMS (Aircraft Condition Monitoring System): Recovers the data supplied by various systems for trend monitoring. It is also possible to use the ACMS for specific troubleshooting.

Usual data requested before starting a Handling Qualities Analysis:

- Flight Data Recorder raw data
- Post Flight Report
- Load and Trim sheet
- Aircraft Condition Monitoring System reports (Load Report 15, Over-Speed Report 35, etc.)
- Trouble-Shooting Data (TSD)
- Pilot's report
- Weather data
- MEL (Minimum Equipment List) open items
- Part Numbers (PN) of the aircraft's computers involved in the occurrence

Applicable process for in-service events

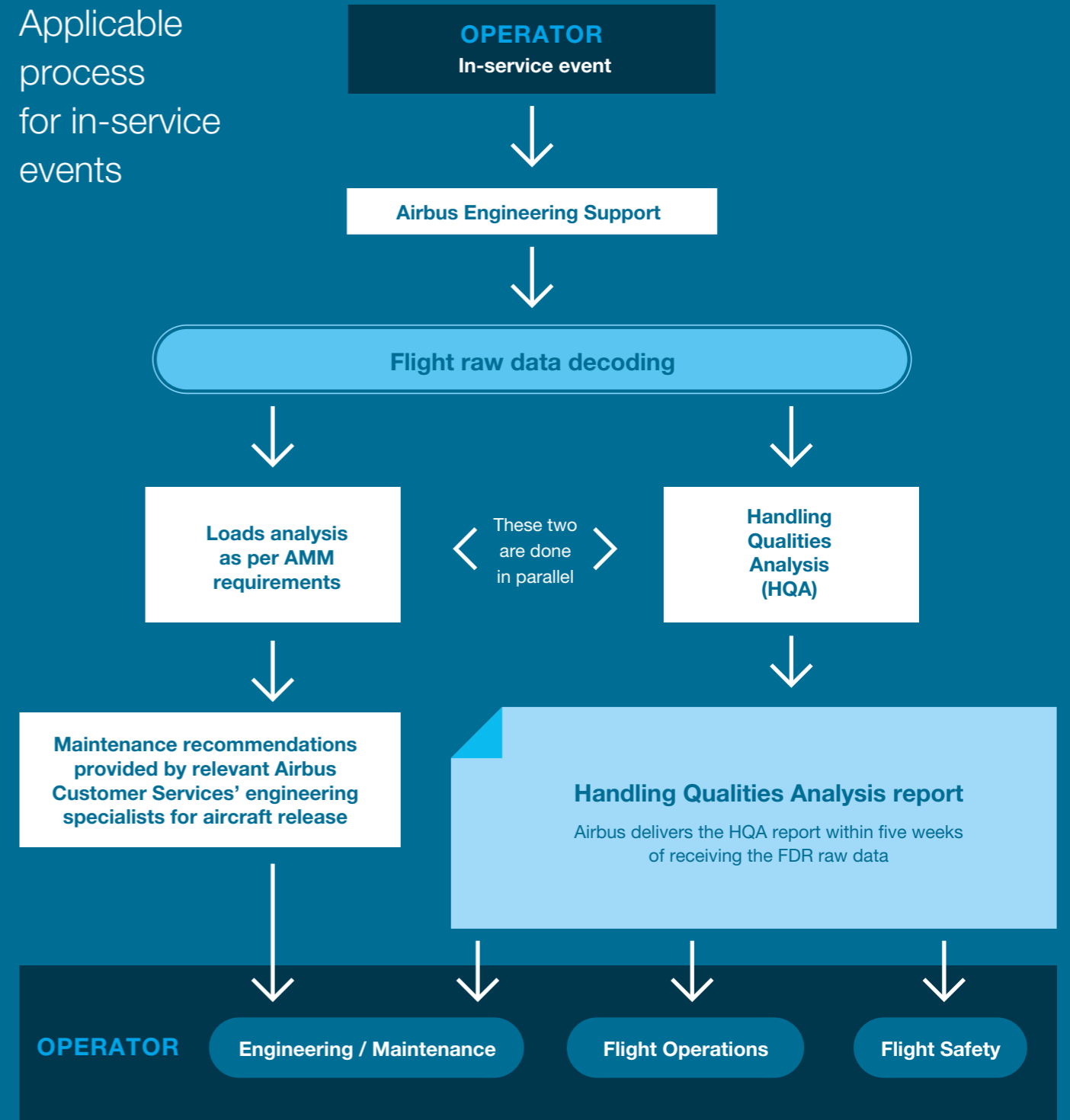

Wind reconstruction

Whenever relevant, Airbus initiates a wind reconstruction (3 axes) to better assess the effect of each wind component (vertical, lateral and longitudinal) on the aircraft behaviour.

In the same way, in case of an aircraft performance issue, the aircraft's Gross Weight (GW) and Centre of Gravity (CG) can be re-computed and compared to the data used/inserted by the crew.

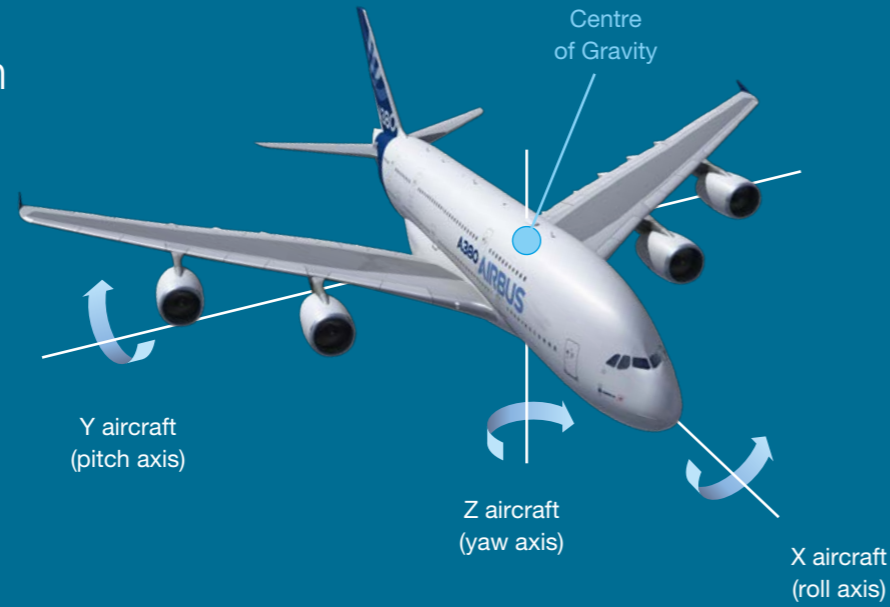

A380 crosswind landing campaign in Reykjavik (Iceland)



Lateral wind's influence on an aircraft's trajectory

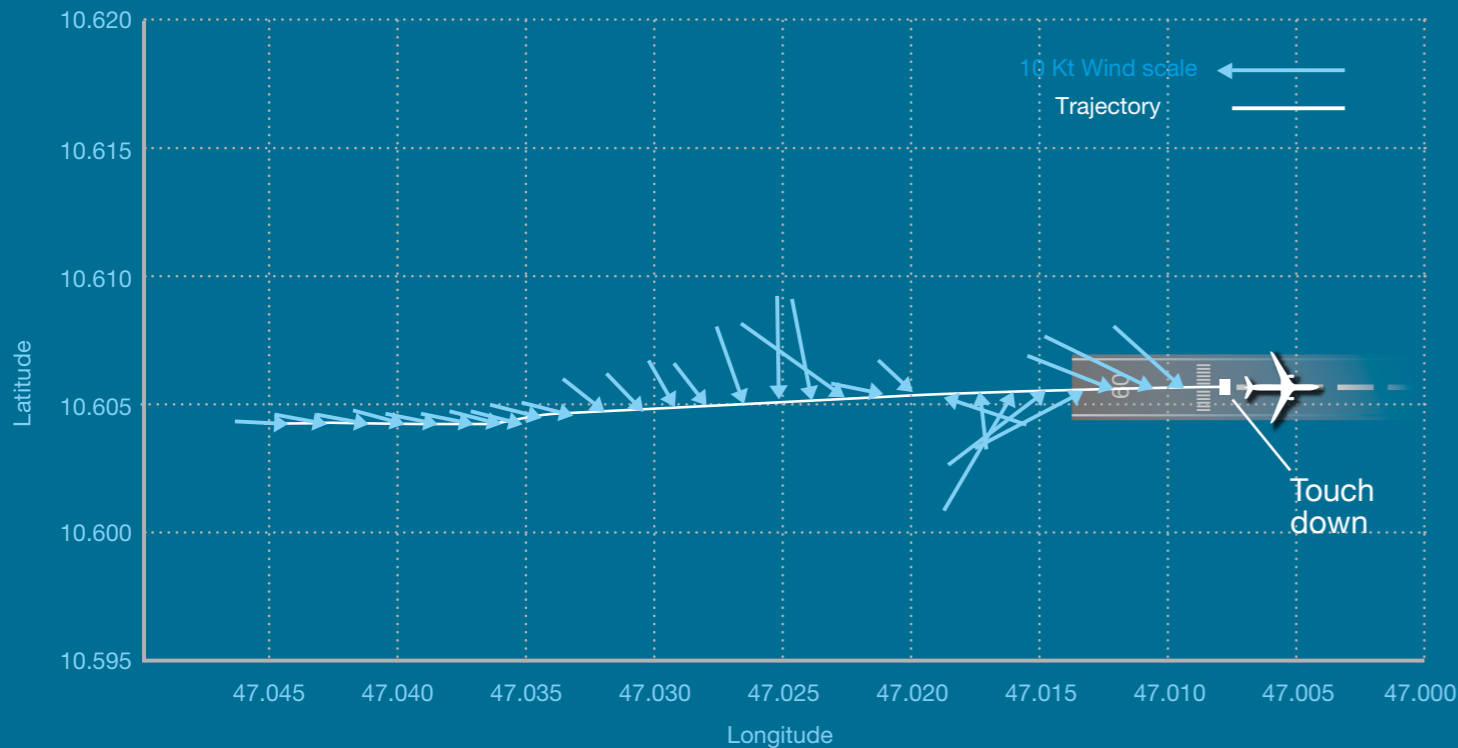

CONCLUSION

Handling Qualities Analysis report provides operators with a synthetic document addressing significant in-service reported events. Airbus' operators receive a detailed analysis highlighting the contributing factors, to ease the understanding of the in-service event. Its intention is to help the operators prevent re-occurrences. When necessary, Airbus provides information to the operator on the eventual system improvements. Thanks to this activity, Airbus proactively supports its operators in maximizing their operations and preventing re-occurrence, with safety as first objective.

Airlines' feedback

"Thank you for the new handling report. It enables us to better understand what happened from a technical point and is an invaluable help for our internal investigation. We especially welcome your prompt replies and the detailed and precise answers to our specific questions. Our company's Flight Safety department highly appreciates your assistance. Once again thank you for your invaluable support."

Peter KRUPA
Training Captain A320 Chief Investigator

"Your report is very professional and very useful."

Mr. Qingchen WANG
Vice-President Safety

"I would like to thank Airbus' HQA team for providing us with the extensive analysis of this event. The report was straightforward and data analysis was complete. This has already been forwarded to the training department to be included in our in-service events, and will form part of our special training session."

Captain MARALIT
A319/A320 Chief Pilot

A350 XWB Electrical Structure Network

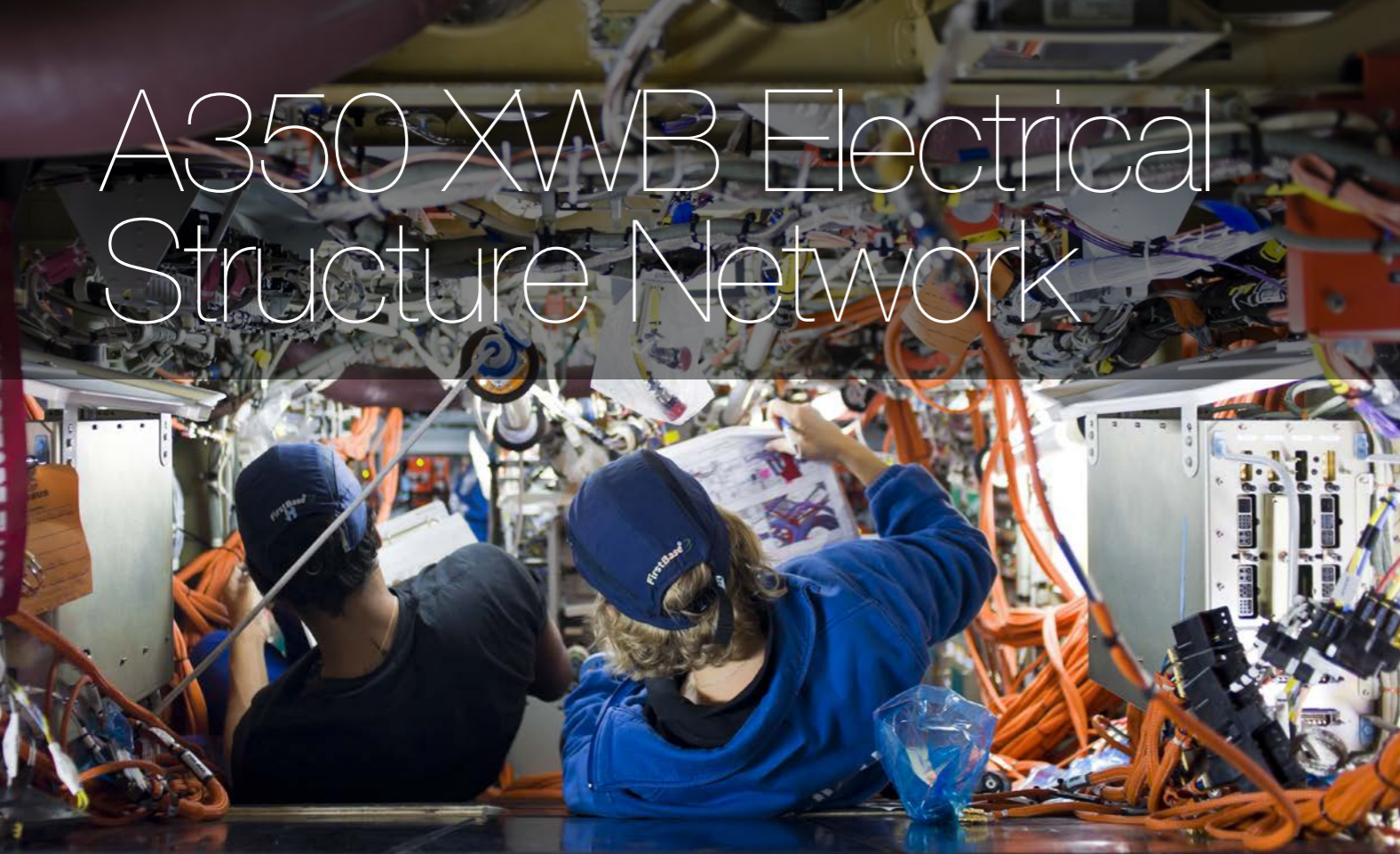

The use of carbon for aircraft structures on the A350 XWB (Extra Wide Body) presents several advantages in terms of weight and maintenance, but leads to differences in system functioning, compared to a metallic structure. This article presents the Electrical Structure Network (ESN), and its particularities with regards to maintenance, the associated documentation and the proposed training means.

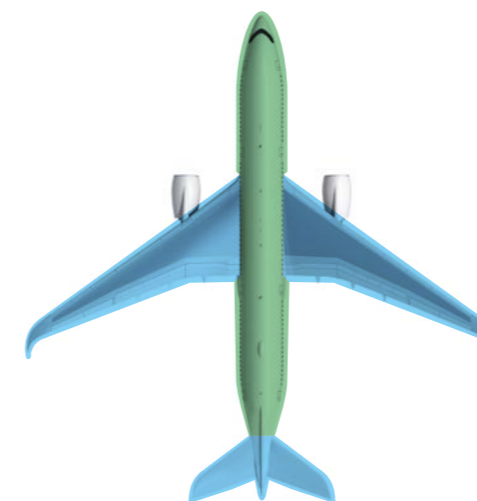

■ Electrical Structure Network (ESN) area
■ Metallic Bonding Network (MBN) area

The Electrical Structure Network is necessary to ensure:

- Proper functioning of the aircraft systems
- Aircraft's structure integrity (loss of mechanical properties in the Carbon Fibre Reinforced Polymer (CFRP) due to the joule effect)
- Staff and passenger safety

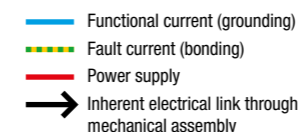

Electrical principle

Your usual home electrical installation

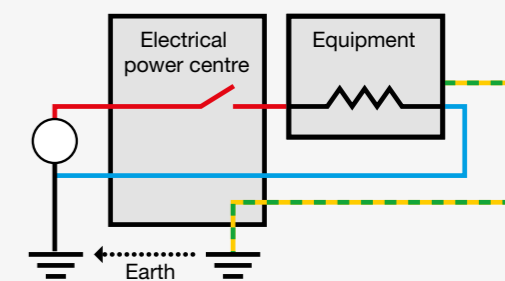

A330 (metallic aircraft)

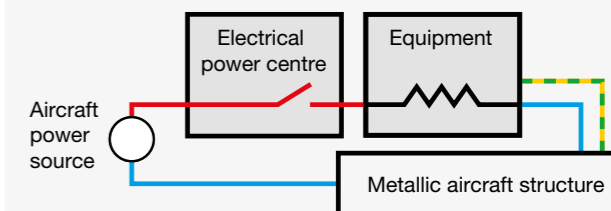

A350 XWB (CFRP fuselage)

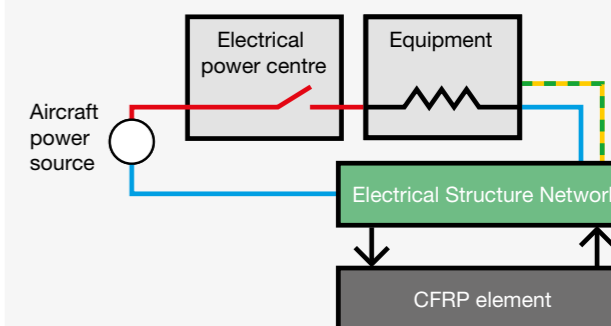

Christophe LOCHOT (left)
ESN Design Leader
Expert in Electrical Systems Engineering
AIRBUS
christophe.lochot@airbus.com

Damien SLOMIANOWSKI (right)
Engineer
Aircraft Electrical Installation & Standard Items
Customer Services Engineering
AIRBUS
damien.slomianowski@airbus.com

To achieve the same electrical and environmental performance of aircraft metallic structures, two different technical solutions have been implemented on the A350 XWB depending on the area and the expected function.

In the pressurized fuselage a highly distributed conductive network; known as the **Electrical Structure Network (ESN)** is achieved thanks to both existing metallic structure parts and to specific ESN parts. This network offers the electrical and environmental conditions required for the correct functioning of aircraft systems. Due to the discrete characteristics and electrical properties of carbon, compared to a metallic fuselage, particular attention should be given to maintaining the ESN system's performance during the entire life of the aircraft.

Elsewhere a **Metallic Bonding Network (MBN)** has already been used. For example on the wings, tail cone, empennage and belly fairing of the A380. It consists of a network of metallic parts, electrically bonded together and used for a failure current return path, equipment bonding, as well as lightning and Electro-Static Discharge protection. This network is neither used as a functional current path (grounding), nor to distribute the voltage reference to the equipment located in the area. These functions are ensured thanks to dedicated cables routed in the harnesses. Each MBN sub-network (wings, belly fairing, etc.) is connected to the ESN.



Parts supporting the ESN

Electrical Structure Network definition

ESN is a metallic redundant and passive network made of more than 6,000 parts. 40% of these parts have specifically been defined for the ESN (specific components), the other ones are metallic parts already installed in the aircraft for mechanical functions.

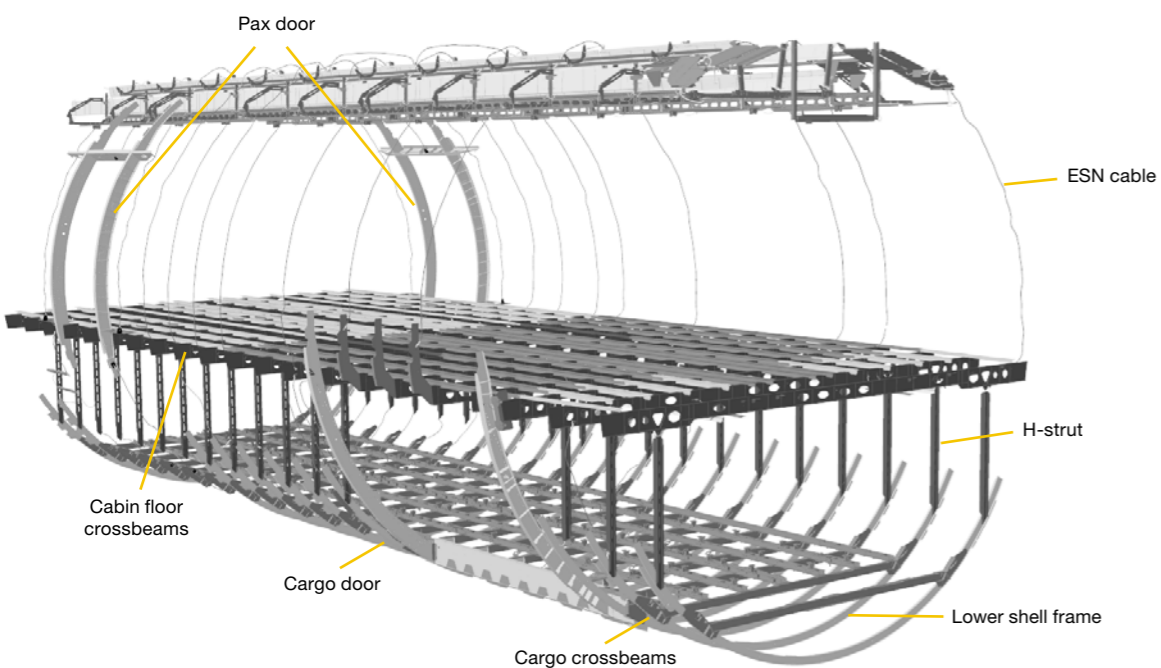
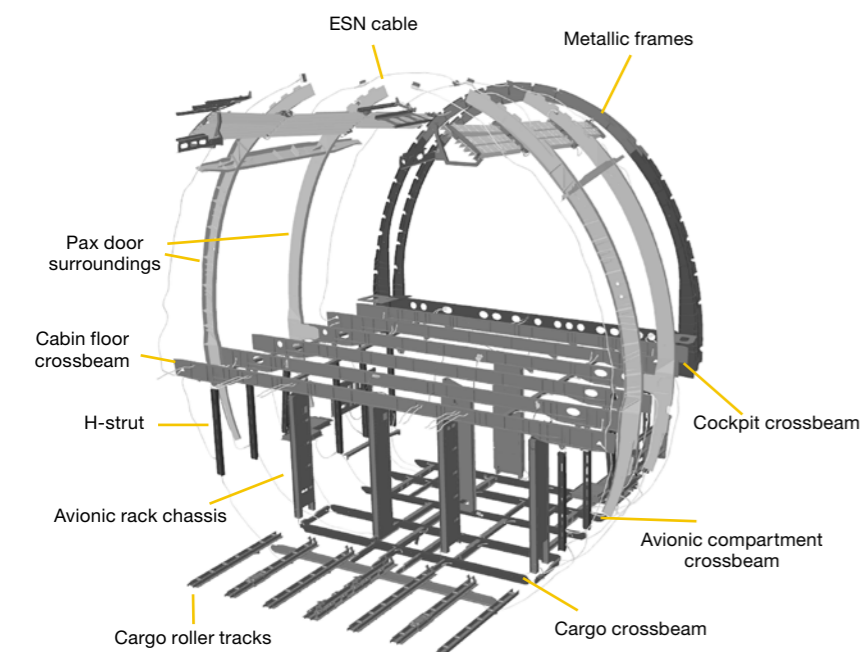

ESN is composed of different element families, which are:

- **Structure metallic elements** (e.g. metallic frames, crossbeams, seat tracks, roller tracks, etc.) and their assembly,
- **Mechanical elements** (e.g. parts supporting equipment such as the electronics bay rack, mechanical junctions, cabin furnishing structures in the crown area) and their assembly,
- **Specific ESN components** (raceways with approximately 2.000 flexible junctions all along the fuselage and cables).

The specific ESN components are the:

- Cables used to create the link between the crown level, and the passenger floor or cargo. This cable is routed by itself and sometimes in a harness.
- Different types of raceways, located in the crown area and under the cabin floor.
- Different types of flexible junctions providing additional means to either reinforce electrical bonding between main elements (e.g. crossbeam, frames, etc.) or create the electrical continuity (e.g. between two raceways).

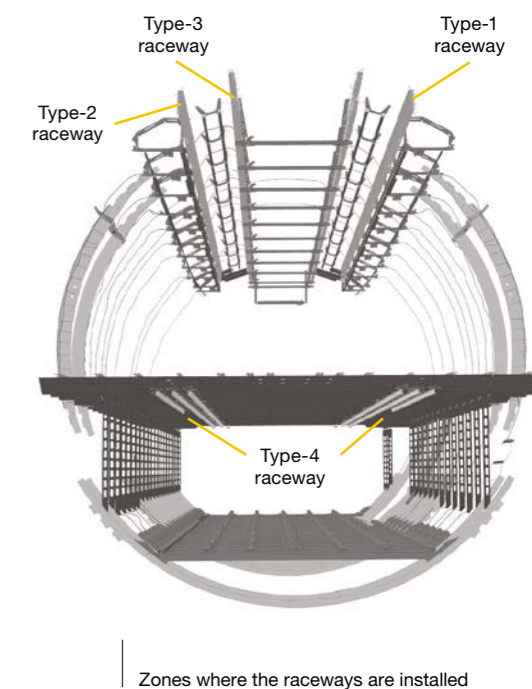
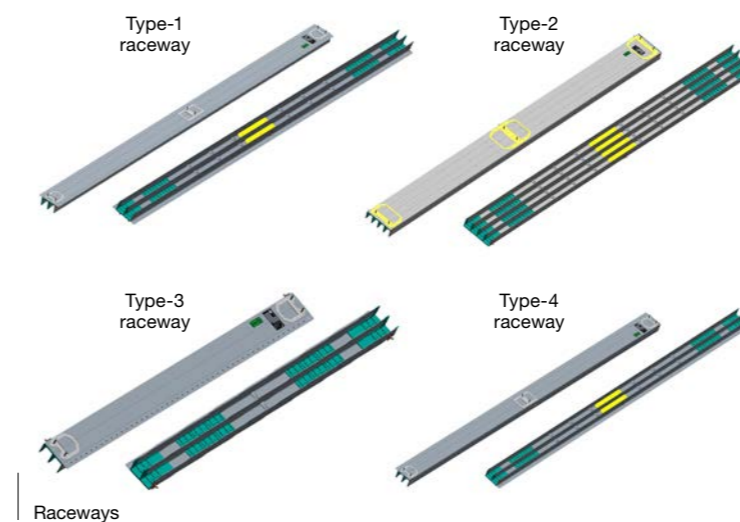



Flexible junctions |

The Point of Voltage Reference (PVR)

Located in the nose area at the passenger floor level, the PVR is the zero volt reference shared by all aircraft equipment. The neutral of the aircraft alternating current power sources and the cold point of the aircraft's direct current sources are connected to the PVR, as well as the neutral of the external ground carts. The PVR is made of metallic frames, in the nose fuselage area, longitudinal beams (called PVR-bars) and their associated flexible junctions.

ESN parts documentation

ESN elements are described in current AirN@v documentation (Airbus technical documentation software):

- In the Illustrated Part Data (IPD), all ESN parts will be specifically flagged,
- In the Maintenance Procedure (MP) all necessary maintenance instructions will be described to ensure the continued airworthiness of the aircraft. These instructions will be located in chapter 20 (e.g. the bonding procedure) and chapter 24-77 (named Electrical Structural Network, new chapter introduced for the A350 XWB). This dedicated chapter will deal with generic safety precautions which apply to all ESN maintenance/repair activities. All ESN tasks will refer to this chapter,
- In the Electrical Standard Practices Manual (ESPM), it will give descriptive data and procedures for the electrical standard parts' installations (e.g. raceways, flexible junctions, etc.). It will provide instructions for part removal and installation, damage assessment and repair solutions to be applied, if deemed necessary,
- In the structural repair manual, allowable damage limits and repairs will take into account the ESN requirements.



ESN parts identification on aircraft

In order to ease the ESN identification and maintenance on the A350 XWB, the specific ESN components, as its secondary structure parts, are identified with a green label.

ESN in use:

In order not to isolate an ESN element (loss of local redundancy), ESN shall be managed with care and generic rules shall be respected.

Maintenance

a - Installation/Removal/Repair:

- In case of repair, electrical properties have to be maintained between the different elements.
- To validate the flexible junction installation (surface preparation, application of the right torque value), a test under high current will have to be performed for each electrical connection.
- To remove and install ESN parts Airbus' documentation needs to be followed in order to ensure the operator's safety.
- Precautions are similar to the ones applicable to electrical systems on legacy programmes.

b - Scheduled inspection

The ESN in-service integrity is ensured thanks to the scheduled maintenance, to be performed in accordance with the documentation found in AirN@v.

Scheduled maintenance will be performed through general visual inspections during the zonal inspections planned, every six years for ESN parts located in the nose fuselage (and especially close to the PVR) and every twelve years for the complete fuselage.

Aircraft modification

The ESN modification has to be treated with precaution. In case of operator modification needs, the following cases shall be considered:

- In case of system modification or addition, an electrical load analysis has to be done for return current in order to guarantee the performance of the ESN (current injection scenarios). This ESN Electrical Load Analysis is similar to the one performed for the electrical power generation and distribution system.
- Any ESN physical modifications have to be analysed by Airbus before their implementation.

Training

Airbus provides training that allows airlines to increase their ESN knowledge and to train electricians or mechanics for maintenance purposes:

ATA 24 Electrical Structure Network Maintenance (levels 2 and 3) and the ESN Measurement/ Test tool,

ATA 51 Electrical Structure Network (ESN) and Metallic Bonding Network (MBN) awareness.

These are part of mandatory courses for B1 and B2 aircraft maintenance licences (specific aeronautical qualifications).

CONCLUSION

To provide a similar electrical environment offered by metallic fuselages for the aircraft systems, Electrical Structure Network (ESN) has been introduced in composite fuselages. This metallic electrical network is mainly built from elements with mechanical functions already present in the aircraft.

Composite fuselages, even with the addition of the ESN, offer the optimal solution in terms of weight and electrical performance while minimizing operational and maintenance costs for airlines.

For maintenance and aircraft modifications, some comparable precautions to those applicable for the electrical power generation and distribution have to be taken. Airlines will receive the appropriate Airbus technical documentation and dedicated support for their A350 XWB. Airbus has already implemented appropriate training courses for operators who wish to learn more about ESN, before the A350 XWB Entry-Into-Service.

Towards a high European air traffic demand

Airbus' involvement in SESAR



Article by

Daniel CHIESA (left)

SESAR Work Package 11.1 Leader

AIRBUS

daniel.chiesa@airbus.com

Joseph ABOROMMAN (right)

SESAR Work Package 11.1 Project Manager

AIRBUS

joseph.aboromman@airbus.com

Time has come to act for the European airspace as air traffic is expected to increase. Currently, constraints in Europe's fragmented airspace bring extra costs of close to 5 billion Euros each year to airlines and their customers.

In order to avoid the risk of saturation of Europe's skies and airports, the European Commission launched an ambitious initiative in 2004: the Single European Sky (SES).

While the Single European Sky is a high level goal at a political level, SESAR (Single European Sky ATM Research) represents its technological pillar and is coordinated by the SESAR Joint Undertaking (SJU), a public and private partnership co-financed by Eurocontrol and the aviation industry.

Within the SESAR programme, Airbus is leading the "Aircraft systems" and "Flight and Wing Operations Centres"(FOC/WOC) Work Packages (WP). Airbus also contributes to several other WPs in which entities such as Air Navigation Service Providers (ANSP), airports or equipment manufacturers are involved. In addition, Airbus also provides industrial support to the SESAR Joint Undertaking (SJU) for managing the overall SESAR programme.

In this article, we will introduce the domains in which the SESAR programme focuses on, and demonstrate in particular where Airbus has taken part in this global partnership.

Single European Sky (SES)

The Single European Sky initiative has been launched to reform the architecture of the European Air Traffic Management (ATM). It proposes a legislative approach to meet the airspace's future capacity and safety needs at a European, rather than a local level.

Contrary to the United States, Europe does not have a single sky, one in which air navigation is managed at the European level. Furthermore, European airspace is amongst the busiest in the world with over 33,000 flights on busy days and a high airport density. This makes air traffic control even more complex.

SESAR

As part of the SES initiative, SESAR (Single European Sky ATM Research) represents its technological and operational dimension. The SESAR programme will help create a "paradigm shift", supported by state-of-the-art and innovative technology, in order to give Europe a high-performance air traffic control infrastructure.

This programme promotes and ensures the interoperability at global level with other initiatives in other parts of the world, by following the ICAO Global Air Navigation Plan (GANP) and ICAO's Aviation System Blocks Upgrades (ASBU) concept.

A partnership programme

For the first time, all aviation players are involved in the three phases of the pan-European modernization project:

- The '**definition phase**' which delivered the ATM master plan defining the content, the development and deployment plans of the next generation of ATM systems. This definition phase was led by Eurocontrol, and co-funded by the European Commission under the Trans European Network-Transport programme and executed by a large consortium of all air transport stakeholders.
- The '**development phase**' which produces the required new generation of technological systems, components and operational procedures as defined in the SESAR ATM Master Plan and Work Programme.
- The '**deployment phase**' will see the large scale production and implementation of the new ATM infrastructure, composed of fully harmonized and interoperable components that guarantee high performance air transport activities in Europe.

SESAR Joint Undertaking (SJU)

Taking into account the number of actors involved in SESAR, the financial resources and the technical expertise needed, it was vital for the rationalization of activities to set up a legal entity pursuant to Article 171 of the European Treaty (on the functioning of the European Union) capable of ensuring the management of the funds assigned to the SESAR project during its 'development phase'. Hence, the SJU was established in 2007 to implement the technology pillar of the SES and, in this respect, is in charge of the SESAR project development phase, i.e. is the guardian and the executor of the European ATM Master Plan.



The most recent version of the ATM Master Plan, approved in 2012, identifies the essential operational changes that need to be implemented in three main steps to lead to the full deployment of the new SESAR concept by 2030:

- Step 1** Time based operations - concentrates on unlocking latent capability particularly by improving information sharing to optimize network effects.
- Step 2** Trajectory based operations - develops the System Wide Information Management (SWIM) and initial trajectory management concepts to increase efficiency.
- Step 3** Performance based operations/improvements - will introduce a full and integrated trajectory management with new separation modes to achieve the long term political goal of SES.

The ATM Master Plan also includes the deployment baseline operational and technological changes which are pre-requisite to operate and support the essential operational changes of 'step 1'.

Compared to the ATM performance in 2005, SESAR's targets for both the 'deployment baseline' and the 'step 1' are the following:

- A 27 % increase in airspace capacity,
- An associated improvement in safety so that the total number of ATM-induced incidents and serious or risk bearing incidents do not increase despite traffic growth generated by SESAR (i.e. through air-space and airport-capacity increase),
- A 2.8 % reduction per flight in environmental impact,
- A 6 % reduction in cost per flight.

SESAR programme

The SESAR programme is divided in several Work Packages (WP) composed of several projects. The WPs are also divided in several categories and sub-categories.

Airbus is the leader of WP 9 and 11.1

“A Work Package for every step of the flight.”

Key steps:

- Time based operations
- 4D trajectory operations
- Performance based operations over a SWIM/IP network

TOC Top Of Climb

TOD Top Of Descent

- Network
- Information management
- Transversal
- Airport
- TMA
- En route

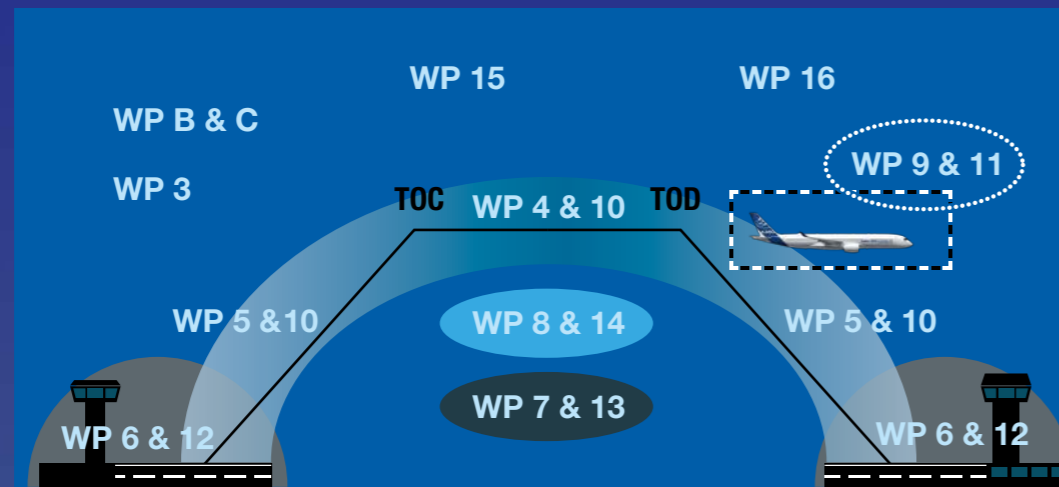

Operational activities

WP 4 En-Route Operations

The scope of the En-Route Operations WP is to provide the operational concept description for the En-Route Operations and perform its validation.

WP 5 Terminal Operations

The scope of this WP is to manage, co-ordinate and perform all activities required to define and validate the ATM target concept (i.e. concept of operations and system architecture) for the arrival and departure phases of flight.

WP 6 Airport Operations

The scope of the Airport Operations WP is to refine and validate the concept definition through the preparation and the coordination of its operational validation process. The concept addresses developments associated with the “airside” elements, such as airfield capacity management and continuous best use of available infrastructure under all weather conditions.

WP 7 Network Operations

The scope of this WP covers the evolution of services in the business development and planning phases to prepare and support trajectory-based operations including airspace management, collaborative flight planning and Network Operations Plan (NOP).

WP E SESAR Long Term and Innovative Research

This WP addresses long-term and innovative research. WP E does not have a fixed work programme but solicits proposals from the research community for the formation of networks of expertise and for project works.

System development activities

WP 9 Aircraft Systems (Airbus leader)

The scope of WP 9 covers the required evolutions of the aircraft platform, in particular to progressively introduce 4D trajectory management functions (three spatial dimensions, plus time) in mainline, regional and business aircraft.

The future, performance-based European ATM system, as defined in the SESAR ATM Master Plan, foresees greater integration and optimum exploitation of the aircraft. In order to reach this objective, a series of ‘capability levels’ have been scheduled. Each capability level provides a stepped performance improvement, synchronized across all components (and stakeholders) of the ATM system.

This work package aims at:

- Developing and validating at aircraft level all airborne functions identified in the SESAR ATM Master Plan.
- Ensuring operational & functional consistency across stakeholder airborne segments (commercial aircraft, business aviation, general aviation, military aircraft, Unmanned Aircraft Systems (UAS), etc.).
- Identifying technical solutions for different airborne platform types such as mainline aircraft, regional aircraft and business jets.
- Insuring global interoperability and coordination with important external initiatives such as NextGen (Next Generation) in the United States.

WP 10 En-Route & Approach ATC Systems

WP 10 designs, specifies and validates the En-route and TMA-ATC (Terminal Air Traffic Control) systems’ evolutions for enhancing trajectory management, separation modes, controller tools, safety nets, airspace management supporting functions and tools, queue management and route optimisation features.

WP 12 Airport Systems

WP 12 encompasses all Research and Development (R&D) activities to define, design, specify and validate the airport systems needed to support the SESAR ATM target concept.

WP 13 Network Information Management System

WP 13 covers the system and technical R&D tasks related to the Network Information Management System (NIMS), the Advanced Airspace Management System (AAMS) and the Aeronautical Information Management System (AIMS).

WP 15 Non-Avionic CNS System

WP 15 (Non-Avionic CNS System) addresses CNS (Communication, Navigation & Surveillance) technologies’ development and validation, also considering their compatibility with the military and general aviation user needs.



Courtesy of Eurocontrol

Operational and system development activities

WP 11.1 Flight and Wing Operations Centres (Airbus leader)

The Flight Operations Centre (FOC) is the Operations Control Center for a civil airspace user and the Wing Operations Centre (WOC) is the Operations Centre for a military airspace user.

WP 11.1 covers the basis of operation for the future FOC/WOC, its role, responsibilities, interactions and exchanges with other actors from an operational point of view, taking in consideration the fundamental systems' architectures. The FOC/WOC system will enable airlines and military operators running this system to reach the performance and safety targets of the SESAR environment. The main objectives of WP 11.1 include:

- Defining FOC/WOC and non FOC/WOC operational concepts from the airspace user's perspective.
- Ensuring overall consistency of the business/mission trajectory management concept from the airspace user's perspective.
- Defining FOC/WOC operations and non FOC/WOC operations operational and performance requirements for each element of the FOC/WOC and for each airspace user category.
- Getting the buy-in of the airspace user's community.
- Providing the system definition, system requirements and system architecture for a generic FOC/WOC that meet the user's needs for a FOC/WOC operating in the SESAR target ATM network.
- Providing the system definition, system requirements and system architecture enabling the airspace users that are not supported by FOC, an access to the SESAR ATM environment.
- To develop prototypes which demonstrate that requirements are compliant with the production of open standards as developed and used in the entire SESAR project philosophy.
- To perform the pre-operational validation of solutions developed within WP 11.1.

WP 11.2 Meteorological Information Services

WP 11.2 addresses the critical dependency between weather, the environment, and the SESAR programme. WP 11.2 provides the SJU and its partners with the opportunity to properly integrate weather into the SESAR programme to enhance the likelihood of success of its final outcomes, and ensuring successful operational implementation of the future air transport system. As the Meteorological (MET) service federating project within the programme, WP 11.2 will ensure consistency and coordination of the MET architecture, systems and services used by all SESAR projects.

SWIM Connecting the ATM world

The concept of SWIM (System Wide Information Management) covers a complete change in paradigm of how information is managed along its full lifecycle and across the whole European ATM system.

WP 8 Information Management

The scope of this WP is to develop SWIM which is the 'intranet for ATM'.

WP 14 SWIM Technical Architecture

This WP is the follow-up of the SWIM- SUIT* FP6 Commission. It will use as an input the SWIM-SUIT deliverables and align them with the SESAR Work Programme components.

* SWIM-Suit is shorthand for SWIM-Supported by Innovative Technologies.

Transverse activities

WP B Target Concept and Architecture Maintenance

WP B, as a transverse work package, provides strategic and conceptual guidance for the entire work programme including all threads (operational, technical and SWIM) to ensure the consistent development of SESAR improvements.

WP C Master Plan Maintenance

The scope of the Master Plan Maintenance WP is to administrate the up-to-date maintenance tasks of the ATM Master Plan, to monitor the progress of its development and its implementation.

WP 3 Validation Infrastructure Adaptation and Integration

WP 3 involves all relevant European ATM stakeholders to benefit from existing expertise, tools and validation platforms, to make available a reference Validation and Verification infrastructure to be used during the SESAR development phase.

WP 16 R&D Transversal Areas

The scope of this WP covers the improvements needed to adapt the Transversal Area (TA) management system practices to SESAR, as well as towards an integrated management system in the fields of safety, security, environment, contingency and human performance.

Parallel programmes

Similar initiatives to SESAR regarding the Air Traffic Management transformation programmes were launched in other parts of the world; for example, in the United States through the Next Generation Air Transport System (NextGen) while in Japan with the Collaborative Actions for Renovation of the Air Traffic System (CARATS).

Conversely, Europe and the United States agreed to cooperate on SESAR and NextGen through a Memorandum of Cooperation (MoC) in civil aviation research and development.

Business/mission trajectory

"Business trajectory" relates to civil users, and "mission trajectory" relates to military users.

A 4D trajectory which expresses the intentions of the user with or without constraints includes both ground and airborne segments of the aircraft operation (gate-to-gate) and is built from, and updated with, the most timely and accurate data available.



Courtesy of Eurocontrol

CONCLUSION

The European Air Traffic Management (ATM) system is operating close to its limits and is facing the challenge of continuously growing demand in air transport. The Single European Sky (SES) initiative was created at a political level in order to achieve the performance objectives and the targets of the future ATM system in Europe.

The SESAR (Single European Sky ATM Research) programme, representing the technological dimension of the SES, has brought together for the first time in European ATM history, the major stakeholders in European aviation to develop the ATM target concept through new processes, procedures and supporting technologies.

Airbus, as one of the SESAR members, is leading two particular Work Packages (WP) of the SESAR programme, therefore contributing to safer and more efficient skies. Airspace users expect their requirements for the ATM system to be better accommodated in order to strengthen the air transport value chain. The ATM target concept is centred around the characteristic of the business trajectory with the purpose of operating a flight as close as the preferred trajectory by the airspace user.

The challenge of developing the new ATM architecture through a wide cooperation between all the involved stakeholders implies a long and strong coordination. Hence, the SESAR programme has, and will, ensure its continuous and consistent development for the years to come.

GLOSSARY

4D	4 dimensions (3 spatial dimensions + time)
ANSP	Air Navigation Service Provider
ATM	Air Traffic Management
CNS	Communication Navigation Surveillance
FOC	Flight Operations Centre
ICAO	International Civil Aviation Organization
NextGen	Next Generation (USA)
SES	Single European Sky
SESAR	Single European Sky ATM Research
SJU	SESAR Joint Undertaking
SWIM	System Wide Information Management
TMA	Terminal control Area
WOC	Wing Operations Centre
WP	Work Package



Volcanic eruptions

Ashes to AVOID

Following the Eyafjallajökull volcano eruption in April 2010, airspace was shut down due to the massive ash cloud prediction covering most parts of northern Europe.

This event grounded aircraft for several days, with an immediate economic impact for airlines. On top of this, stranded passengers expressed dissatisfaction, not understanding why aircraft could not fly through an invisible ash cloud.

A visible ash plume containing larger particles of ash spread over several kilometres from the volcano vent, but the dominant winds dispersed and pushed finer particles much further, not visible to the eye but nevertheless, still there.



Article by

Manfred BIRNFELD

Senior Flight Test Engineer/Senior Expert
AIRBUS

manfred.birnfeld@airbus.com

Concerted efforts have been made by Airbus' customer easyJet, Nicarnia Aviation of Norway and Airbus, with the help of technicians from the Duesseldorf University of Applied Sciences Laboratory of Environmental Measurement

Techniques, to make a significant step in the development of a system to be able to "see" fine particles of volcanic ash suspended in the air in order to "avoid" them.

This article will take you through the flight test performed in October 2013 to validate a new system called simply: AVOID (Airborne Volcanic Object Imaging Detector).

In May of this year, using the very first A400M, close to one metric ton of genuine volcanic ash from the Eyafjallajökull was collected from the Icelandic Institute of volcanology.

The ash was then taken to Alès in southern France for milling, reducing the grain size to about 25 microns, to resemble fine volcanic ash that had been transported in the atmosphere over more than 2000 km.

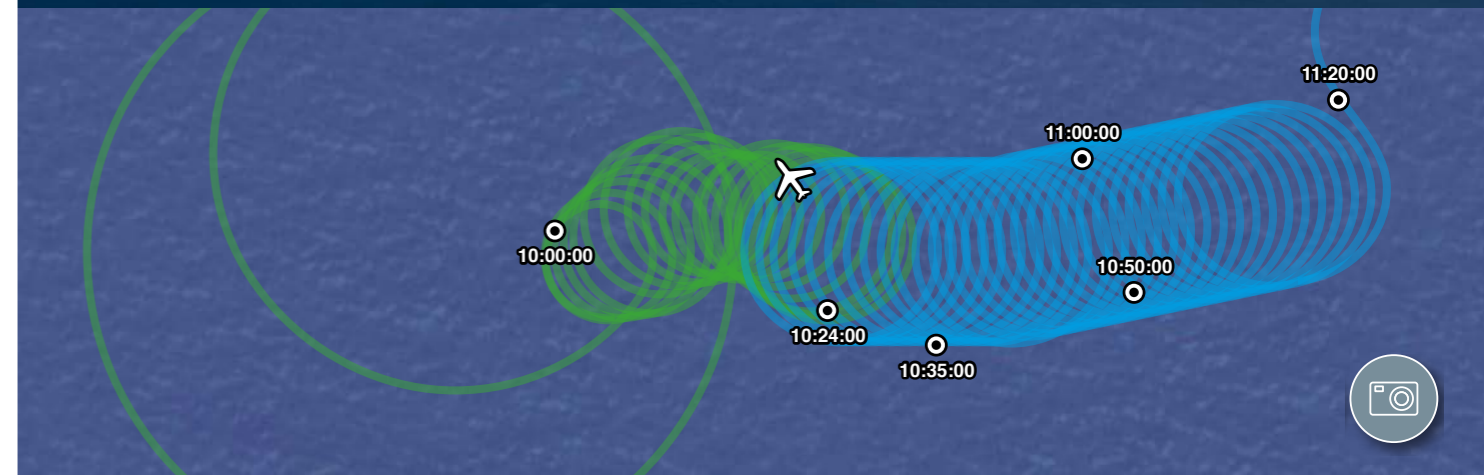

The A400M had been prepared with special devices employing the differential of the fuselage's pressure in flight, controlled to an elevated level, allowing dispersal of the ash from the barrels into the air behind the aircraft.

The A400M spiralled in a 3 km diameter circle, climbing each half turn by a small amount, ensuring it would not enter the ash cloud it had produced.

Two teams of four trained ash handlers emptied all the ash barrels according to a time schedule which, together with the geometry of the circles flown with help of a precise bank angle mode, would produce the ash cloud in the desired uniformity and concentrations targeted.





The second aircraft on the scene was a small twin piston engine propeller aircraft, a Diamond DA 42 from the manufacturer's plant in Vienna. Brought over and operated by scientists from Düsseldorf's University of Applied Science, it was fitted with special sampling devices, able to detect and measure in-situ the content and the characteristics of the volcanic ash cloud produced by the A400M.

Tasks for the DIAMOND DA 42 MPP aircraft during the experiment:

- Perform in-situ ash measurements with high accuracy
- Track the plume geometry
- Determine the size distribution of the ash particles
- Transmit the measurement result on-line to the A340



A third aircraft, A340 MSN 001 carried the AVOID sensor for which the cloud had been made. The device consists of a pair of infrared (IFR) cameras intended to capture the IFR signature of the scenery in front of the aircraft. The camera's IFR imagery is analysed using filtering techniques which dissociate the IFR absorption in order to identify when absorption by volcanic ash particles has taken place. It uses this technique to detect the presence of volcanic ash in front of the aircraft.

At an altitude of more than 30,000 feet, it would be able to "see" ash of a significant concentration at a distance of 100 km. The more ash in the air, the higher the measured IFR absorption will be. When perfectly calibrated, the measurement can be developed to give a reliable reading of the "ash loading" (mass per surface area, in g/m²) ahead of the aircraft.

The experiment was the first time the AVOID sensor was exposed to realistic volcanic ash while being carried by a civil transport aircraft.

After the volcanic eruptions of Eyafjallajökull (2010) and Grimsvötn (2011) in Iceland, Airbus teamed up with Nicarnia Aviation, the developer of the AVOID sensor, and easyJet who is sponsoring AVOID's development, aiming to make proof of concept tests and develop the sensor.

Initial trials had been carried out in July 2012 which validated the installation principle and explored the flight envelope of the A340 with the sensor installed. One of the main purposes of these trials was to look for absence of false detections. The sensor was therefore not intended to be exposed to volcanic ash during these trials. However, on one occasion on a long flight south, the sensor detected the presence of Saharian dust in the air. This dust's IFR absorption is very similar to volcanic ash since it contains similar chemical components.

The entire test was filmed by a fourth aircraft: Aerovision's specially equipped Corvette to video and photograph the three aircraft at work in flight.



Inside the 'cavernous' A400M MSN 001 preparing for volcanic ash distribution



Airbus Flight Test Specialist Julie MAUTIN and Céline COHEN of Assystem using pressure differentials to 'vacuum' the barrels of ash

Infrared imagery

Impossible to discriminate ash from other clouds

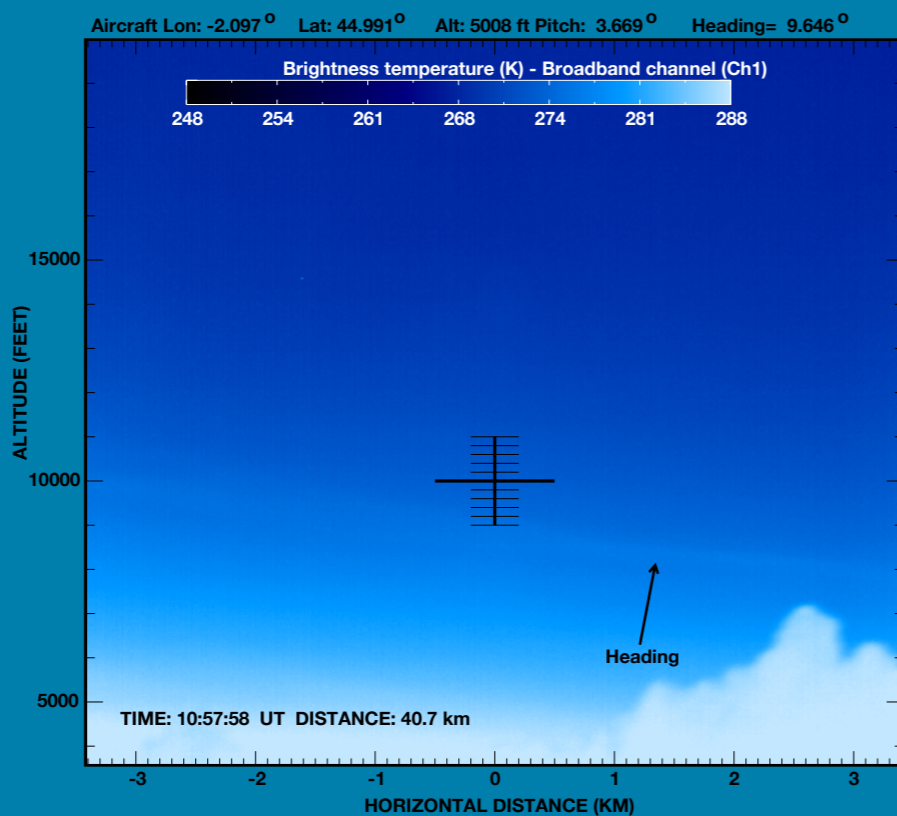

Detection of volcanic ash using AVOID

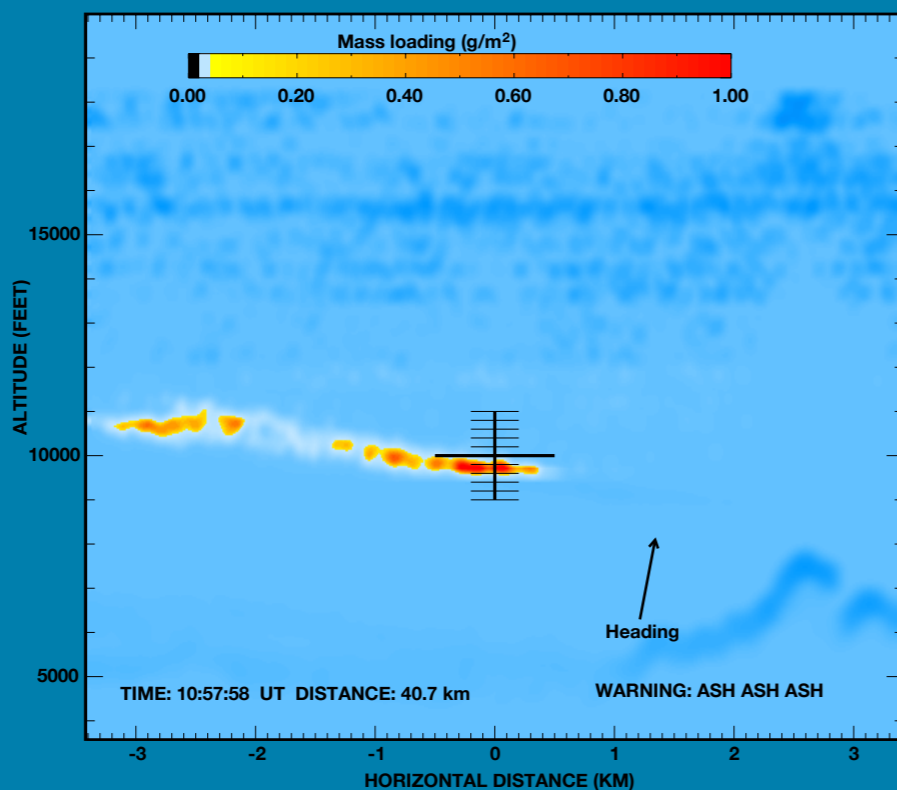

The trials in July 2012 were successful and gave the initiative for the next step: exposure to a real volcanic ash cloud.

As the precise time and place of a volcanic eruption are absolutely unpredictable, the idea of making a small, but representative cloud was rapidly born.

The A400M which was conducting flight tests had the capabilities to precisely execute the spiralling flight path required and it had the cargo hold allowing a team to work at the dispersion of the ash.

The ash release and detection experiment made on 30th October 2013 represents a success in several aspects:

- We have been able to artificially create a representative volcanic ash cloud with the predicted size and distribution.
- The ash particles measured inside the cloud were identified as being very similar if not identical to ash particles captured over Europe during the 2010 Eyafjallajökull eruption.
- It demonstrated real time data availability from in-situ measurements. The ash measurement data were transmitted in real time from the DA42 to the A340 MSN 001 using satellite data communication and a simple Internet site.

And the main result: the AVOID sensor images captured the volcanic ash cloud from a distance of 50 km. Given the small size of our cloud and the resulting low “mass loading”, it was a great success. It is now realistic to believe that detection of significant ash loading at a distance of 100 km is feasible.

What's next?

Although the results of this experiment are very encouraging, the AVOID sensor is still in a prototype condition. It will need development with automatism replacing the scientist's individual intervention for the IFR data interpretation. That will take some time.

The data produced needs to be analysed and integrated into the big puzzle of information necessary to make flying in the vicinity of volcanic ash safe. There are several interesting work packages to be defined. It could well be that in the future a pilot will be given information that integrates AVOID sensor's data. It will be Airbus' task to work on an integrated system and develop, potentially together with a system manufacturer, the necessary system philosophy and cockpit interface.

In the meantime, easyJet plans to develop a stand alone solution, with the aim of producing an instrument which can enhance flight safety when operating in the vicinity of volcanic ash clouds. This would be used conforming to the rules of a safety assessment integrating all available data from forecasting, satellite imagery and local observation.

CONCLUSION

The Icelandic volcano eruptions in 2010 and 2011 brought home the necessity to be able to measure the risk of volcanic ash contamination of air space and avoid grounding traffic unnecessarily.

A joint initiative between easyJet, Nicarnia Aviation and Airbus set about developing an air contamination detection system named AVOID. The Duesseldorf University of Applied Sciences' Laboratory of Environmental Measurement Techniques, participated, providing key services and in-situ measurement techniques.

This system was tested in October 2013 with a small cloud of fine ash released into the atmosphere by an Airbus A400M. It demonstrated the AVOID sensor detection capability. Real time data was available from in-situ measurements. Ash measurement data were transmitted in real time from a DA42 sampling the cloud, to an A340; these were compared with infrared observations made by the AVOID system. AVOID's sensors captured the volcanic ash cloud from a distance of 50 km. Given the size and low “mass loading” of the cloud, the results are encouraging.

In time AVOID sensors could be integrated into aircraft systems to inform pilots of ash presence at up to 100 km ahead.

Volcanoes are not really predictable, and they're unstoppable. Their ash clouds significantly disturb flying if the threat of the particles is not measurable. AVOID is destined to help us avoid situations like the traffic grounding for Eyafjallajökull.

FAST from the PAST

There wouldn't be any future without the experience of the past.

Concorde MSN 2 - 1970

Concorde's all metal frame made bonding easy and needed no supplementary Electrical Structure Network (read article page 20). This still meant an impressive amount of cables that needed to be channeled throughout the aircraft.

Even with the advent of optic fibre cabling, each successive Airbus programme uses more wiring as new technology is developed.

Airbus' largest aircraft the A380 uses an amazing 350 kilometres of cables.

Photo courtesy of EADS corporate heritage

We've got it covered

Around the clock, around the world,
Airbus has more than 240 field representatives
based in over 110 cities

WORLDWIDE

Tel: +33 (0)5 6719 1980
Fax: +33 (0)5 6193 1818

USA/CANADA

Tel: +1 703 834 3484
Fax: +1 703 834 3464

CHINA

Tel: +86 10 8048 6161 Ext. 5020
Fax: +86 10 8048 6162

FIELD SERVICE SUPPORT ADMINISTRATION

Tel: +33 (0)5 6719 0413
Fax: +33 (0)5 6193 4964

TECHNICAL, MATERIAL & LOGISTICS

Airbus Technical AOG Centre (AIRTAC)
Tel: +33 (0)5 6193 3400
Fax: +33 (0)5 6193 3500
airtac@airbus.com

Spares AOG/Work Stoppage

- Outside the Americas:
Tel: +49 (0)40 5076 4001
Fax: +49 (0)40 5076 4011
aog.spares@airbus.com
- In the Americas:
Tel: +1 70 3729 9000
Fax: +1 70 3729 4373
aog.na@airbus.com

Spares In-Flight orders *outside the Americas:*

Tel: +49 (0)40 5076 4002
Fax: +49 (0)40 5076 4012
ifd.spares@airbus.com

Spares related HMV issues *outside the Americas:*

Tel: +49 (0)40 5076 4003
Fax: +49 (0)40 5076 4013
hmv.spares@airbus.com

Spares RTN/USR orders *in the Americas:*

Please contact your dedicated customer spares
account representative csr.na@airbus.com

TRAINING CENTRES

Airbus Training Centre
Toulouse, France
Tel: +33 (0)5 6193 3333
Fax: +33 (0)5 6193 2094

Airbus Maintenance
Training Centre
Hamburg, Germany
Tel: +49 (0)40 7438 8288
Fax: +49 (0)40 7438 8588

Airbus Training Centre Americas
Miami, Florida - U.S.A.
Tel: +1 305 871 3655
Fax: +1 305 871 4649



Airbus, its logo and the product names are registered trademarks.

With the A380, the sky is yours. The A380 is designed to maximize airline revenues. By scheduling the A380 on constrained slots and high yield routes, airlines will experience a significant uplift of passengers to really take advantage of high yield traffic. That means higher market share, maximized slot profitability and higher revenues.

Own the sky
A380



AIRBUS