



A380

**AIRCRAFT CHARACTERISTICS
AIRPORT AND MAINTENANCE PLANNING**

AC

The content of this document is the property of Airbus.

It is supplied in confidence and commercial security on its contents must be maintained.

It must not be used for any purpose other than that for which it is supplied, nor may information contained in it be disclosed to unauthorized persons.

It must not be reproduced in whole or in part without permission in writing from the owners of the copyright. Requests for reproduction of any data in this document and the media authorized for it must be addressed to Airbus.

© AIRBUS S.A.S. 2005. All rights reserved.

*AIRBUS S.A.S.
Customer Services
Technical Data Support and Services
31707 Blagnac Cedex
FRANCE*

HIGHLIGHTS**Revision No. 19 - Nov 01/24**

LOCATIONS	CHG CODE	DESCRIPTIONS OF CHANGE
CHAPTER 5 Section 5-5 Subject 5-5-0 Engine Starting Pneumatic Requirements	R	ADDED THE INFORMATION RELATED TO THE GLOBAL REQUIREMENTS FOR THE AIRFLOW START FOR ONE ENGINE.
Section 5-8 Subject 5-8-0 Ground Towing Requirements	R	ADDED INFORMATION RELATED TO ROTATING TOWEYE IN THE SUBTASK.

LIST OF EFFECTIVE CONTENT**Revision No. 19 - Nov 01/24**

CONTENT	CHG CODE	LAST REVISION DATE
CHAPTER 1		
Subject 1-1-0		Nov 01/20
Introduction		
Subject 1-2-1		Dec 01/23
Glossary		
CHAPTER 2		
Subject 2-1-1		Feb 01/19
General Aircraft Characteristics Data		
Subject 2-2-0		Dec 01/13
General Aircraft Dimensions		Feb 01/19
FIGURE General Aircraft Dimensions		
Subject 2-3-0		Dec 01/14
Ground Clearances		Dec 01/14
FIGURE Ground Clearances		Dec 01/14
FIGURE Ground Clearances - Leading Edge Slats - Extended		Dec 01/14
FIGURE Ground Clearances - Trailing Edge Flaps - Extended		Dec 01/14
FIGURE Ground Clearances - Spoilers - Extended		Dec 01/13
FIGURE Ground Clearances - Ailerons - Down		Dec 01/14
FIGURE Ground Clearances - Ailerons - Up		Dec 01/14

CONTENT	CHG CODE	LAST REVISION DATE
FIGURE Ground Clearances - Flap Tracks - Extended		Dec 01/14
FIGURE Ground Clearances - Trimmable Horizontal Stabilizer and Elevators - Down		Dec 01/14
Subject 2-4-0		
Interior Arrangement - Plan View		Dec 01/15
FIGURE Interior Arrangements - Plan View - Standard Configuration - Upper Deck		Dec 01/15
FIGURE Interior Arrangements - Plan View - Standard Configuration - Main Deck		Dec 01/15
Subject 2-5-0		
Interior Arrangements - Cross Section		Dec 01/15
FIGURE Interior Arrangements - Cross Section - Typical Configuration - Upper Deck		Dec 01/15
FIGURE Interior Arrangements - Cross Section - Typical Configuration - Main Deck		Dec 01/15
Subject 2-6-0		
Cargo Compartments		Dec 01/15
FIGURE Cargo Compartments - Location and Dimensions		Dec 01/16
FIGURE Cargo Compartments - Loading Combinations		Dec 01/16
Subject 2-7-0		
Door Clearances		Dec 01/14
FIGURE Door Clearances - Door Location (Sheet 1)		Dec 01/13

CONTENT	CHG CODE	LAST REVISION DATE
FIGURE Door Clearances - Door Location (Sheet 2)		Dec 01/13
FIGURE Door Clearances - Forward Passenger Doors		Dec 01/15
FIGURE Door Clearances - Main and Upper Deck Passenger Doors		Dec 01/15
FIGURE Door Clearances - Aft Passenger Doors		Dec 01/15
FIGURE Door Clearances - Forward Cargo Compartment Door		Dec 01/15
FIGURE Door Clearances - Aft Cargo Compartment Doors		Dec 01/15
FIGURE Door Clearances - Forward Nose Landing Gear Doors		Dec 01/15
FIGURE Door Clearances - Wing Landing Gears - Main Doors		Dec 01/14
FIGURE Door Clearances - Body Landing Gears - Outer Doors		Dec 01/14
FIGURE Door Clearances - APU Doors		Dec 01/14
Subject 2-8-0		
Escape Slides		Dec 01/15
FIGURE Escape Slides - Location		Dec 01/15
FIGURE Escape Slides - Dimensions		Dec 01/15
Subject 2-9-0		
Landing Gear		Dec 01/16
FIGURE Wing Landing Gear - General		Dec 01/15
FIGURE Body Landing Gear - General		Dec 01/15

CONTENT	CHG CODE	LAST REVISION DATE
FIGURE Nose Landing Gear - General		Dec 01/16
Landing Gear Maintenance Pits		Dec 01/15
FIGURE Landing Gear Maintenance Pits - Maintenance Pit Envelopes		Dec 01/13
FIGURE Landing Gear Maintenance Pits - Necessary Depths		Dec 01/13
FIGURE Landing Gear Maintenance Pits - Maintenance Pit Envelopes - WLG Pit Dimensions		Dec 01/13
FIGURE Landing Gear Maintenance Pits - Maintenance Pit Envelopes - BLG Pit Dimensions		Dec 01/13
Subject 2-10-0		Dec 01/13
Exterior Lighting		Dec 01/13
FIGURE Exterior Lighting		Dec 01/13
FIGURE Exterior Lighting		Dec 01/13
FIGURE Exterior Lighting		Dec 01/13
FIGURE Exterior Lighting		Dec 01/13
FIGURE Exterior Lighting		Dec 01/13
Subject 2-11-0		Dec 01/13
Antennas and Probes Location		Dec 01/13
FIGURE Antennas and Probes - Location		Dec 01/13
Subject 2-12-0		Dec 01/13
Auxiliary Power Unit		Dec 01/13

CONTENT	CHG CODE	LAST REVISION DATE
FIGURE Auxiliary Power Unit - Access Doors		Dec 01/13
FIGURE Auxiliary Power Unit - General Layout		Dec 01/13
Engine and Nacelle		Dec 01/13
FIGURE Power Plant Handling - Engine Dimensions - GP 7200 Engine		Dec 01/13
FIGURE Power Plant Handling - Nacelle Dimensions - GP 7200 Engine		Dec 01/13
FIGURE Power Plant Handling - Fan Cowls - GP 7200 Engine		Dec 01/13
FIGURE Power Plant Handling - Thrust Reverser Cowls - GP 7200 Engine		Dec 01/13
FIGURE Power Plant Handling - Fan Exhaust Cowls - GP 7200 Engine		Dec 01/15
FIGURE Power Plant Handling - Engine Dimensions - TRENT 900 Engine		Dec 01/13
FIGURE Power Plant Handling - Nacelle Dimensions - TRENT 900 Engine		Dec 01/13
FIGURE Power Plant Handling - Fan Cowls - TRENT 900 Engine		Dec 01/13
FIGURE Power Plant Handling - Thrust Reverser Cowls - TRENT 900 Engine		Dec 01/13
FIGURE Power Plant Handling - Fan Exhaust Cowls - TRENT 900 Engine		Dec 01/15
Subject 2-13-0		
Leveling, Symmetry and Alignment		Dec 01/13

CONTENT	CHG CODE	LAST REVISION DATE
FIGURE Location of Leveling Points Subject 2-14-0		Dec 01/13
Jacking for Maintenance		Dec 01/16
FIGURE Jacking for Maintenance - Jacking Points Location		Dec 01/13
FIGURE Jacking for Maintenance - Jacking Dimensions		Dec 01/13
FIGURE Jacking for Maintenance - Forward Jacking Point		Dec 01/13
FIGURE Jacking for Maintenance - Wing Jacking Point		Dec 01/13
FIGURE Jacking for Maintenance - Auxiliary Jacking Point - Safety Stay		Dec 01/13
Jacking of the Landing Gear		Dec 01/16
FIGURE Nose Landing Gear Jacking Point Heights		Dec 01/13
FIGURE Wing Landing Gear Jacking Point Heights		Dec 01/13
FIGURE Body Landing Gear Jacking Point Heights		Dec 01/13
CHAPTER 3 Subject 3-1-0		
General Information		Dec 01/13
Subject 3-2-1		
Payload/Range - ISA Conditions		Dec 01/14
FIGURE Payload/Range - ISA Conditions - TRENT 900 Engines		Dec 01/13
FIGURE Payload/Range - ISA Conditions - GP 7200 Engines		Dec 01/13
Subject 3-3-1		

CONTENT	CHG CODE	LAST REVISION DATE
Take-Off Weight Limitation - ISA Conditions		Dec 01/14
FIGURE Take-Off Weight Limitation - ISA Conditions - TRENT 900 Engines		Dec 01/14
FIGURE Take-Off Weight Limitation - ISA Conditions - GP 7200 Engines		Dec 01/14
Subject 3-3-2		Feb 01/19
Take-Off Weight Limitation - ISA + 15 °C (+27 °F) Conditions		Feb 01/19
FIGURE Take-Off Weight Limitation - ISA + 15 °C (+27 °F) Conditions - TRENT 900 Engines		Feb 01/19
FIGURE Take-Off Weight Limitation - ISA + 15 °C (+27 °F) Conditions - GP 7200 Engines		Feb 01/19
Subject 3-3-3		Nov 01/20
Aerodrome Reference Code		
Subject 3-4-1		Dec 01/14
Landing Field Length		Dec 01/14
FIGURE Landing Field Length - Dry Runway		Dec 01/14
Subject 3-5-0		Dec 01/13
Final Approach Speed		Dec 01/13
<u>CHAPTER 4</u>		
Subject 4-1-0		Dec 01/13
General		
Subject 4-2-0		Dec 01/14
Turning Radii		Dec 01/14

CONTENT	CHG CODE	LAST REVISION DATE
FIGURE Turning Radii - (Sheet 1)		Dec 01/14
FIGURE Turning Radii - (Sheet 2)		Dec 01/14
Subject 4-3-0 Minimum Turning Radii		Dec 01/14
FIGURE Minimum Turning Radii		Dec 01/14
Subject 4-4-0 Visibility from Cockpit in Static Position		Dec 01/13
FIGURE Visibility from Cockpit in Static Position		Feb 01/19
FIGURE Binocular Visibility Through Windows from Captain Eye Position		Dec 01/13
Subject 4-5-0 Runway and Taxiway Turn Paths		Dec 01/13
Subject 4-5-1 135° Turn - Runway to Taxiway		Dec 01/13
FIGURE 135° Turn – Runway to Taxiway - Judgemental Oversteer Method		Dec 01/13
FIGURE 135° Turn – Runway to Taxiway - Cockpit Tracks Centreline Method		Dec 01/13
Subject 4-5-2 90° Turn - Runway to Taxiway		Dec 01/13
FIGURE 90° Turn – Runway to Taxiway - Judgemental Oversteer Method		Dec 01/13

CONTENT	CHG CODE	LAST REVISION DATE
FIGURE 90° Turn – Runway to Taxiway - Cockpit Tracks Centreline Method Subject 4-5-3		Dec 01/13
180° Turn on a Runway FIGURE 180° Turn on a Runway		Dec 01/13
Subject 4-5-4 135° Turn - Taxiway to Taxiway		Feb 01/19
FIGURE 135° Turn – Taxiway to Taxiway - Judgemental Oversteer Method		Nov 01/20
FIGURE 135° Turn – Taxiway to Taxiway - Cockpit Tracks Centerline Method		Nov 01/20
Subject 4-5-5 90° Turn - Taxiway to Taxiway		Nov 01/20
FIGURE 90° Turn – Taxiway to Taxiway - Judgemental Oversteer Method		Nov 01/20
FIGURE 90° Turn – Taxiway to Taxiway - Cockpit Tracks Centerline Method		Nov 01/20
Subject 4-6-0 Runway Holding Bay (Apron)		Dec 01/13
FIGURE Runway Holding Bay (Apron)		Dec 01/13
Subject 4-7-0 Minimum Line-Up Distance Corrections		Feb 01/19

CONTENT	CHG CODE	LAST REVISION DATE
FIGURE Minimum Line-Up Distance Corrections - 90° Turn on Runway Entry		Feb 01/19
FIGURE Minimum Line-Up Distance Corrections - 180° Turn on Runway Turn Pad		Feb 01/19
FIGURE Minimum Line-Up Distance Corrections - 180° Turn on Runway Width		Feb 01/19
Subject 4-8-0 Aircraft Mooring		Dec 01/13
FIGURE Aircraft Mooring		Dec 01/13
<u>CHAPTER 5</u> Subject 5-1-0 Aircraft Servicing Arrangements		Dec 01/14
Subject 5-1-1 Typical Ramp Layout (Open Apron)		Dec 01/15
FIGURE Typical Ramp Layout - Open Apron		Dec 01/13
Subject 5-1-2 Typical Ramp Layout (Gate)		Dec 01/15
FIGURE Typical Ramp Layout - Gate		Dec 01/13
Subject 5-2-1 Typical Turn-Round Time - Standard Servicing Via Main Deck and Upper Deck		Feb 01/19
FIGURE Typical Turn-Round Time - Servicing Via Main and Upper Deck Subject 5-2-2		Feb 01/19

CONTENT	CHG CODE	LAST REVISION DATE
Typical Turn-Round Time - Servicing Via Main Deck		Feb 01/19
FIGURE Typical Turn-Round Time - Servicing Via Main Deck		Feb 01/19
Subject 5-4-1		
Ground Service Connections Layout		Dec 01/13
FIGURE Ground Service Connections Layout		Dec 01/13
Subject 5-4-2		
Grounding (Earthing) Points		Dec 01/14
FIGURE Grounding (Earthing) Point - NLG		Dec 01/14
FIGURE Grounding (Earthing) Points - WLG		Dec 01/14
FIGURE Grounding (Earthing) Points - BLG		Dec 01/14
Subject 5-4-3		
Hydraulic Servicing		Dec 01/15
FIGURE Ground Service Connections - Hydraulic Reservoir Servicing Panel		Dec 01/14
FIGURE Ground Service Connections - Hydraulic Ground Connections		Dec 01/13
Subject 5-4-4		
Electrical Servicing		Dec 01/23
FIGURE Ground Service Connections - Electrical Service Panel		Dec 01/13
FIGURE Ground Service Connections - Ram Air Turbine Retracted		Dec 01/14
FIGURE Ground Service Connections - Ram Air Turbine Extended		Dec 01/14

CONTENT	CHG CODE	LAST REVISION DATE
Subject 5-4-5 Oxygen System		Dec 01/14
FIGURE Ground Service Connections - Oxygen System		Dec 01/13
Subject 5-4-6 Fuel Servicing		Dec 01/15
FIGURE Ground Service Connections - Refuel/Defuel Control Panel		Dec 01/13
FIGURE Ground Service Connections - Pressure Refuel Connections		Dec 01/13
FIGURE Ground Service Connections - Overpressure Protector and NACA Flame Arrestor - Wing		Dec 01/14
FIGURE Ground Service Connections - Overpressure Protector and NACA Flame Arrestor - Trim Tank		Dec 01/14
Subject 5-4-7 Pneumatic Servicing		Dec 01/15
FIGURE Ground Service Connections - Low Pressure Preconditioned Air		Dec 01/13
FIGURE Ground Service Connections - High Pressure Preconditioned Air		Dec 01/13
Subject 5-4-8 Oil Servicing		Dec 01/15
FIGURE Ground Service Connections - Engine Oil Servicing - TRENT 900 Engines		Dec 01/15
FIGURE Ground Service Connections - VFG Oil Servicing - TRENT 900 Engines		Dec 01/15

CONTENT	CHG CODE	LAST REVISION DATE
FIGURE Ground Service Connections - Starter Oil Servicing - TRENT 900 Engines		Dec 01/15
FIGURE Ground Service Connections - Engine Oil Servicing - GP7200 Engines		Dec 01/15
FIGURE Ground Service Connections - VFG Oil Servicing - GP7200 Engines		Dec 01/15
FIGURE Ground Service Connections - Starter Oil Servicing - GP7200 Engines		Dec 01/15
FIGURE Ground Service Connections - APU Oil Servicing		Dec 01/15
Subject 5-4-9		Dec 01/15
Potable Water Servicing		Dec 01/14
FIGURE Ground Service Connections - Potable Water Ground Service Panel		Dec 01/14
FIGURE Ground Service Connections - Potable Water Drain Panel		Dec 01/14
FIGURE Ground Service Connections - Potable Water Tanks Location		Dec 01/14
Subject 5-4-10		Dec 01/14
Waste Water System		Dec 01/14
FIGURE Ground Service Connections - Waste Water Ground Service Panel		Dec 01/14
FIGURE Ground Service Connections - Waste Tanks Location		Dec 01/13
Subject 5-4-11		Dec 01/15
Cargo Control Panels		Dec 01/15

CONTENT	CHG CODE	LAST REVISION DATE
FIGURE Forward Cargo Control Panels		Dec 01/14
FIGURE Aft Cargo Control Panels		Dec 01/14
Subject 5-5-0 Engine Starting Pneumatic Requirements	R	Nov 01/24
Subject 5-6-0 Ground Pneumatic Power Requirements		Dec 01/15
FIGURE Ground Pneumatic Power Requirements - Heating		Dec 01/13
FIGURE Ground Pneumatic Power Requirements - Cooling		Dec 01/13
Subject 5-7-0 Preconditioned Airflow Requirements		Dec 01/15
FIGURE Preconditioned Airflow Requirements		Dec 01/13
Subject 5-8-0 Ground Towing Requirements	R	Nov 01/24
FIGURE Ground Towing Requirements		Dec 01/23
FIGURE Ground Towing Requirements - Nose Gear Towing Fittings		Dec 01/13
Subject 5-9-0 De-Icing and External Cleaning		Dec 01/15
CHAPTER 6 Subject 6-1-0 Engine Exhaust Velocities and Temperatures		Dec 01/14
Subject 6-1-1		

CONTENT	CHG CODE	LAST REVISION DATE
Engine Exhaust Velocities - Ground Idle Power		Dec 01/13
FIGURE Engine Exhaust Velocities - Ground Idle Power - TRENT 900 Engines		Dec 01/13
FIGURE Engine Exhaust Velocities - Ground Idle Power - GP 7200 Engines		Dec 01/13
Subject 6-1-2		
Engine Exhaust Temperatures - Ground Idle Power		Dec 01/13
FIGURE Engine Exhaust Temperatures - Ground Idle Power - TRENT 900 Engines		Dec 01/13
FIGURE Engine Exhaust Temperatures - Ground Idle Power - GP 7200 Engines		Dec 01/13
Subject 6-1-3		
Engine Exhaust Velocities - Breakaway Power		Dec 01/13
FIGURE Engine Exhaust Velocities - Breakaway Power - TRENT 900 Engines		Dec 01/13
FIGURE Engine Exhaust Velocities - Breakaway Power - GP 7200 Engines		Dec 01/13
Subject 6-1-4		
Engine Exhaust Temperatures - Breakaway Power		Dec 01/13
FIGURE Engine Exhaust Temperatures - Breakaway Power - TRENT 900 Engines		Dec 01/13
FIGURE Engine Exhaust Temperatures - Breakaway Power - GP 7200 Engines		Dec 01/13
Subject 6-1-5		

CONTENT	CHG CODE	LAST REVISION DATE
Engine Exhaust Velocities - Max Take-off Power		Dec 01/13
FIGURE Engine Exhaust Velocities - Max. Take-Off Power - TRENT 900 Engines		Dec 01/13
FIGURE Engine Exhaust Velocities - Max. Take-Off Power - GP 7200 Engines		Dec 01/13
Subject 6-1-6		
Engine Exhaust Temperatures - Max Take-off Power		Dec 01/13
FIGURE Engine Exhaust Temperatures - Max Take-Off Power - TRENT 900 Engines		Dec 01/13
FIGURE Engine Exhaust Temperatures - Max Take-Off Power - GP 7200 Engines		Dec 01/13
Subject 6-3-0		
Danger Areas of the Engines		Dec 01/13
Subject 6-3-1		
Danger Areas of the Engines - Ground Idle Power		Nov 01/20
FIGURE Danger Areas of the Engines - Ground Idle Power - TRENT 900 Engines		Nov 01/20
FIGURE Danger Areas of the Engines - Ground Idle Power - GP 7200 Engines		Nov 01/20
Subject 6-3-2		
Danger Areas of the Engines - Max. Take-Off Power		Dec 01/13
FIGURE Danger Areas of the Engines - Max Take-Off Power - TRENT 900 Engines		Nov 01/20

CONTENT	CHG CODE	LAST REVISION DATE
FIGURE Danger Areas of the Engines - Max Take-Off Power - GP 7200 Engines		Nov 01/20
Subject 6-3-3		
Danger Areas of the Engines - Breakaway Power		Dec 01/13
FIGURE Danger Areas of the Engines - Breakaway Power - TRENT 900 Engines		Dec 01/13
FIGURE Danger Areas of the Engines - Breakaway Power - GP 7200 Engines		Nov 01/20
Subject 6-4-1		
APU Exhaust Velocities and Temperatures - ECS Conditions		Dec 01/14
FIGURE APU Exhaust Velocities and Temperatures - Max. ECS Conditions		Dec 01/13
Subject 6-4-2		
APU Exhaust Velocities and Temperatures - MES Conditions		Dec 01/13
FIGURE APU Exhaust Velocities and Temperatures - MES Conditions		Dec 01/13
<u>CHAPTER 7</u>		
Subject 7-1-0		
General Information		Nov 01/20
Subject 7-2-0		
Landing Gear Footprint		Dec 01/16
FIGURE Landing Gear Footprint		Feb 01/19
Subject 7-3-0		
Maximum Pavement Loads		Dec 01/14

CONTENT	CHG CODE	LAST REVISION DATE
FIGURE Maximum Pavement Loads		Feb 01/19
Subject 7-4-0		
Landing Gear Loading on Pavement		Nov 01/20
Subject 7-5-0		
Flexible Pavement Requirements - US Army Corps of Engineers Design Method		Nov 01/20
Subject 7-6-0		
Flexible Pavement Requirements - LCN Conversion		Nov 01/20
Subject 7-7-0		
Rigid Pavement Requirements - Portland Cement Association Design Method		Nov 01/20
Subject 7-8-0		
Rigid Pavement Requirements - LCN Conversion		Nov 01/20
Subject 7-9-0		
ACN/PCN Reporting System - Flexible and Rigid Pavements		Nov 01/20
Subject 7-10-0		
ACR/PCR Reporting System - Flexible and Rigid Pavements		Nov 01/20
Subject 7-10-0		
ACR/PCR Reporting System - Flexible and Rigid Pavements		Nov 01/20
Subject 7-10-0		
ACR/PCR Reporting System - Flexible and Rigid Pavements		Nov 01/20
Subject 7-10-0		
ACR/PCR Reporting System - Flexible and Rigid Pavements		Nov 01/20
Subject 7-10-0		
ACR/PCR Reporting System - Flexible and Rigid Pavements		Nov 01/20
Subject 7-10-0		
ACR/PCR Reporting System - Flexible and Rigid Pavements		Nov 01/20
Subject 7-10-0		
ACR/PCR Reporting System - Flexible and Rigid Pavements		Nov 01/20
CHAPTER 8		
Subject 8-0-0		
Scaled Drawings		Dec 01/13
Subject 8-0-0		
Scaled Drawings		Dec 01/13
Subject 8-0-0		
Scaled Drawings		Dec 01/13
Subject 8-0-0		
Scaled Drawings		Dec 01/13
CHAPTER 10		

CONTENT	CHG CODE	LAST REVISION DATE
Subject 10-0-0		
Aircraft Rescue and Fire Fighting		Dec 01/15
FIGURE Front Page		Dec 01/15
FIGURE Highly Flammable and Hazardous Materials and Components		Dec 01/15
FIGURE Batteries Location and Access		Dec 01/15
FIGURE Crew Rest Compartments Location		Dec 01/13
FIGURE Wheel/Brake Overheat - Wheel Safety Area		Dec 01/13
FIGURE Composite Materials Location		Dec 01/13
FIGURE Landing Gear - Ground Lock Safety Devices		Dec 01/13
FIGURE Emergency Evacuation Devices		Dec 01/15
FIGURE Pax/Crew Doors and Emergency Exits		Dec 01/13
FIGURE Cargo Doors - FWD and AFT Lower Deck Cargo Doors		Dec 01/13
FIGURE Control Panels		Dec 01/13
FIGURE APU Compartment Access		Dec 01/13
FIGURE Aircraft Ground Clearances		Dec 01/15
FIGURE Structural Break-in Points		Dec 01/13

TABLE OF CONTENTS

1	SCOPE
1-1-0	Introduction
1-2-1	Glossary
2	AIRCRAFT DESCRIPTION
2-1-1	General Aircraft Characteristics Data
2-2-0	General Aircraft Dimensions
2-3-0	Ground Clearances
2-4-0	Interior Arrangement - Plan View
2-5-0	Interior Arrangements - Cross Section
2-6-0	Cargo Compartments
2-7-0	Door Clearances
2-8-0	Escape Slides
2-9-0	Landing Gear
2-10-0	Exterior Lighting
2-11-0	Antennas and Probes Location
2-12-0	Power Plant
2-13-0	Leveling, Symmetry and Alignment
2-14-0	Jacking
3	AIRCRAFT PERFORMANCE
3-1-0	General Information
3-2-1	Payload/Range - ISA Conditions
3-3-1	Take Off Weight Limitation - ISA Conditions
3-3-2	Take Off Weight Limitation - ISA + 15 °C (27 °F) Conditions
3-3-3	Aerodrome Reference Code
3-4-1	Landing Field Length - ISA Conditions
3-5-0	Final Approach Speed
4	GROUND MANEUVERING
4-1-0	General Information
4-2-0	Turning Radii
4-3-0	Minimum Turning Radii
4-4-0	Visibility from Cockpit in Static Position
4-5-0	Runway and Taxiway Turn Paths
4-5-1	135° Turn - Runway to Taxiway

4-5-2	90° Turn - Runway to Taxiway
4-5-3	180° Turn on a Runway
4-5-4	135° Turn - Taxiway to Taxiway
4-5-5	90° Turn - Taxiway to Taxiway
4-6-0	Runway Holding Bay (Apron)
4-7-0	Minimum Line-Up Distance Corrections
4-8-0	Aircraft Mooring
5	TERMINAL SERVICING
5-1-0	Aircraft Servicing Arrangements
5-1-1	Typical Ramp Layout (Open Apron)
5-1-2	Typical Ramp Layout (Gate)
5-2-1	Typical Turn-Round Time - Standard Servicing Via Main Deck and Upper Deck
5-2-2	Typical Turn-Round Time - Servicing Via Main Deck
5-4-1	Ground Service Connections Layout
5-4-2	Grounding (Earthing) Points
5-4-3	Hydraulic System
5-4-4	Electrical System
5-4-5	Oxygen System
5-4-6	Fuel System
5-4-7	Pneumatic System
5-4-8	Oil System
5-4-9	Potable Water System
5-4-10	Waste Water System
5-4-11	Cargo Control Panels
5-5-0	Engine Starting Pneumatic Requirements
5-6-0	Ground Pneumatic Power Requirements
5-7-0	Preconditioned Airflow Requirements
5-8-0	Ground Towing Requirements
5-9-0	De-Icing and External Cleaning
6	OPERATING CONDITIONS
6-1-0	Engine Exhaust Velocities and Temperatures
6-1-1	Engine Exhaust Velocities - Ground Idle Power
6-1-2	Engine Exhaust Temperatures - Ground Idle Power
6-1-3	Engine Exhaust Velocities - Breakaway Power
6-1-4	Engine Exhaust Temperatures - Breakaway Power
6-1-5	Engine Exhaust Velocities - Max Take-off Power
6-1-6	Engine Exhaust Temperatures - Max Take-off Power

6-3-0	Danger Areas of the Engines
6-3-1	Danger Areas of the Engines - Ground Idle Power
6-3-2	Danger Areas of the Engines - Max. Take-Off Power
6-3-3	Danger Areas of the Engines - Breakaway Power
6-4-1	APU Exhaust Velocities and Temperatures
6-4-2	APU Exhaust Velocities and Temperatures - MES Conditions
7	PAVEMENT DATA
7-1-0	General Information
7-2-0	Landing Gear Footprint
7-3-0	Maximum Pavement Loads
7-4-0	Landing Gear Loading on Pavement
7-5-0	Flexible Pavement Requirements - US Army Corps of Engineers Design Method
7-6-0	Flexible Pavement Requirements - LCN Conversion
7-7-0	Rigid Pavement Requirements - Portland Cement Association Design Method
7-8-0	Rigid Pavement Requirements - LCN Conversion
7-9-0	ACN-PCN Reporting System - Flexible and Rigid Pavements
7-10-0	ACR-PCR Reporting System - Flexible and Rigid Pavements
8	SCALED DRAWINGS
8-0-0	SCALED DRAWINGS
10	AIRCRAFT RESCUE AND FIRE FIGHTING
10-0-0	AIRCRAFT RESCUE AND FIRE FIGHTING

SCOPE

1-1-0 Introduction

****ON A/C A380-800**

Introduction

1. General

The A380 AIRCRAFT CHARACTERISTICS - AIRPORT AND MAINTENANCE PLANNING (AC) manual is issued for the A380 series aircraft to provide necessary data to airport operators, airlines and Maintenance/Repair Organizations (MRO) for airport and maintenance facilities planning.

This document is not customized and must not be used for training purposes. No information within may constitute a contractual commitment.

The A380-800 is a subsonic, very long range and very high capacity civil transport aircraft. The A380-800 offers several payload capabilities ranging from 400 passengers in a very comfortable multi-class configuration, up to 853 passengers in an all economy class configuration.

Designed in close collaboration with major airlines, airports and airworthiness authorities, the A380 is the most spacious and productive aircraft in service setting a new standard in air travel. Due to its unmatched comfort on board the A380 became the passenger's first choice.

Two engine types are currently offered, the Engine Alliance GP7200 series and the Rolls-Royce Trent 900 series. Both engines use state of the art technology for better performance, maintainability, lower fuel consumption and environmental impact.

The A380-800 was designed to be compatible with current airport infrastructure and equipment, as proven in service. Bigger, quieter and capable of achieving quick turn around times, the A380-800 provides an efficient solution for airports and airlines to grow in a sustainable manner.

Having secured 251 orders from 14 customers worldwide, the A380 has been used on more than 150 trunk routes to more than 70 destinations worldwide, for all types of markets, from leisure to high premium.

Correspondence concerning this publication should be directed to:



AIRCRAFT CHARACTERISTICS - AIRPORT AND MAINTENANCE PLANNING

AIRBUS S.A.S.
Customer Services
Technical Data Support and Services
1, Rond Point Maurice BELLONTE
31707 BLAGNAC CEDEX
FRANCE

1-2-1 Glossary****ON A/C A380-800**Glossary

1. List of Abbreviations

A/C	Aircraft
ACN	Aircraft Classification Number
ACR	Aircraft Classification Rating
AMM	Aircraft Maintenance Manual
APU	Auxiliary Power Unit
B/C	Business Class
BLG	Body Landing Gear
CBR	California Bearing Ratio
CC	Cargo Compartment
CG	Center of Gravity
C/L	Center Line
CLS	Cargo Loading System
E	Young's Modulus
ECS	Environmental Control System
ESWL	Equivalent Single Wheel Load
FAA	Federal Aviation Administration
F/C	First Class
FDL	Fuselage Datum Line
FR	Frame
FSTE	Full Size Trolley Equivalent
FWD	Forward
GPU	Ground Power Unit
GSE	Ground Support Equipment
HYD	Hydraulic
ICAO	International Civil Aviation Organisation
ISA	International Standard Atmosphere
L	Radius of Relative Stiffness
LCN	Load Classification Number
LD	Load Device
LD	Lower Deck
LH	Left Hand
LPS	Last Pax Seating
MAC	Mean Aerodynamic Chord

MAX	Maximum
MD	Main Deck
MES	Main Engine Start
MIN	Minimum
NLG	Nose Landing Gear
OAT	Outside Air Temperature
PAX	Passenger
PBB	Passenger Boarding Bridge
PB/D	Passenger Boarding/Deplaning
PCA	Portland Cement Association
PCN	Pavement Classification Number
PCR	Pavement Classification Rating
PRM	Passenger with Reduced Mobility
RH	Right Hand
UD	Upper Deck
ULD	Unit Load Device
US	United States
VFG	Variable Frequency Generator
WLG	Wing Landing Gear
WV	Weight Variant
Y/C	Tourist Class

2. Design Weight Terminology

- Maximum Design Ramp Weight (MRW):
Maximum weight for ground maneuver (including weight of taxi and run-up fuel) as limited by aircraft strength and airworthiness requirements. It is also called Maximum Design Taxi Weight (MTW).
- Maximum Design Landing Weight (MLW):
Maximum weight for landing as limited by aircraft strength and airworthiness requirements.
- Maximum Design Take-Off Weight (MTOW):
Maximum weight for take-off as limited by aircraft strength and airworthiness requirements. (This is the maximum weight at start of the take-off run).
- Maximum Design Zero Fuel Weight (MZFW):
Maximum permissible weight of the aircraft without usable fuel.
- Maximum Seating Capacity:
Maximum number of passengers specifically certified or anticipated for certification.
- Usable Volume:
Usable volume available for cargo, pressurized fuselage, passenger compartment and cockpit.
- Water Volume:
Maximum volume of cargo compartment.



AIRCRAFT CHARACTERISTICS - AIRPORT AND MAINTENANCE PLANNING

- Usable Fuel:
Fuel available for aircraft propulsion.

AIRCRAFT DESCRIPTION

2-1-1 General Aircraft Characteristics Data

****ON A/C A380-800**

General Aircraft Characteristics Data

1. The following table provides characteristics of A380-800 Models, these data are specific to each Weight Variant:

Aircraft Characteristics					
	WV000	WV001	WV002	WV003	WV004
Maximum Ramp Weight (MRW)	562 000 kg	512 000 kg	571 000 kg	512 000 kg	562 000 kg
Maximum Taxi Weight (MTW)	(1 238 998 lb)	(1 128 766 lb)	(1 258 839 lb)	(1 128 766 lb)	(1 238 998 lb)
Maximum Take-Off Weight (MTOW)	560 000 kg	510 000 kg	569 000 kg	510 000 kg	560 000 kg
	(1 234 588 lb)	(1 124 357 lb)	(1 254 430 lb)	(1 124 357 lb)	(1 234 588 lb)
Maximum Landing Weight (MLW)	386 000 kg	394 000 kg	391 000 kg	395 000 kg	391 000 kg
	(850 984 lb)	(868 621 lb)	(862 007 lb)	(870 826 lb)	(862 007 lb)
Maximum Zero Fuel Weight (MZFW)	361 000 kg	372 000 kg	366 000 kg	373 000 kg	366 000 kg
	(795 869 lb)	(820 119 lb)	(806 892 lb)	(822 324 lb)	(806 892 lb)

Aircraft Characteristics					
	WV005	WV006	WV007	WV008	WV009
Maximum Ramp Weight (MRW)	562 000 kg	575 000 kg	492 000 kg	577 000 kg	512 000 kg
Maximum Taxi Weight (MTW)	(1 238 998 lb)	(1 267 658 lb)	(1 084 674 lb)	(1 272 067 lb)	(1 128 766 lb)
Maximum Take-Off Weight (MTOW)	560 000 kg	573 000 kg	490 000 kg	575 000 kg	510 000 kg
	(1 234 588 lb)	(1 263 248 lb)	(1 080 265 lb)	(1 267 658 lb)	(1 124 357 lb)
Maximum Landing Weight (MLW)	386 000 kg	393 000 kg	395 000 kg	394 000 kg	386 000 kg
	(850 984 lb)	(866 416 lb)	(870 826 lb)	(868 621 lb)	(850 984 lb)
Maximum Zero Fuel Weight (MZFW)	366 000 kg	368 000 kg	373 000 kg	369 000 kg	361 000 kg
	(806 892 lb)	(811 301 lb)	(822 324 lb)	(813 506 lb)	(795 869 lb)

Aircraft Characteristics					
	WV010	WV011	WV012	WV013	WV014
Maximum Ramp Weight (MRW)	482 000 kg	577 000 kg	571 000 kg	494 000 kg	574 000 kg
Maximum Taxi Weight (MTW)	(1 062 628 lb)	(1 272 067 lb)	(1 258 839 lb)	(1 089 083 lb)	(1 265 453 lb)
Maximum Take-Off Weight (MTOW)	480 000 kg	575 000 kg	569 000 kg	492 000 kg	572 000 kg
	(1 058 219 lb)	(1 267 658 lb)	(1 254 430 lb)	(1 084 674 lb)	(1 261 044 lb)
Maximum Landing Weight (MLW)	386 000 kg	395 000 kg	395 000 kg	386 000 kg	391 000 kg
	(850 984 lb)	(870 826 lb)	(870 826 lb)	(850 984 lb)	(862 007 lb)
Maximum Zero Fuel Weight (MZFW)	361 000 kg	369 000 kg	366 000 kg	361 000 kg	366 000 kg
	(795 869 lb)	(813 506 lb)	(806 892 lb)	(795 869 lb)	(806 892 lb)

2. The following table provides characteristics of A380-800 Models, these data are common to each Weight Variant:

Aircraft Characteristics	
Standard Seating Capacity	555
Usable Fuel Capacity (density = 0.785 kg/l)	323 546 l (85 472 US gal)
	253 983 kg (559 937 lb)
Pressurized Fuselage Volume (A/C non equipped, main and upper deck)	2 100 m ³ (74 161 ft ³)
Passenger Compartment Volume (main deck)	775 m ³ (27 369 ft ³)
Passenger Compartment Volume (upper deck)	530 m ³ (18 717 ft ³)
Cockpit Volume	12 m ³ (424 ft ³)
Usable Volume, FWD CC (Based on LD3)	89.4 m ³ (3 157 ft ³)

Aircraft Characteristics	
Usable Volume, AFT CC (Based on LD3)	71.5 m ³ (2 525 ft ³)
Usable Volume, Bulk CC	14.3 m ³ (505 ft ³)
Water Volume, FWD CC	131 m ³ (4 626 ft ³)
Water Volume, AFT CC	107.8 m ³ (3 807 ft ³)
Water Volume, Bulk CC	17.3 m ³ (611 ft ³)

2-2-0 General Aircraft Dimensions

****ON A/C A380-800**

General Aircraft Dimensions

1. This section provides General Aircraft Dimensions.

****ON A/C A380-800**

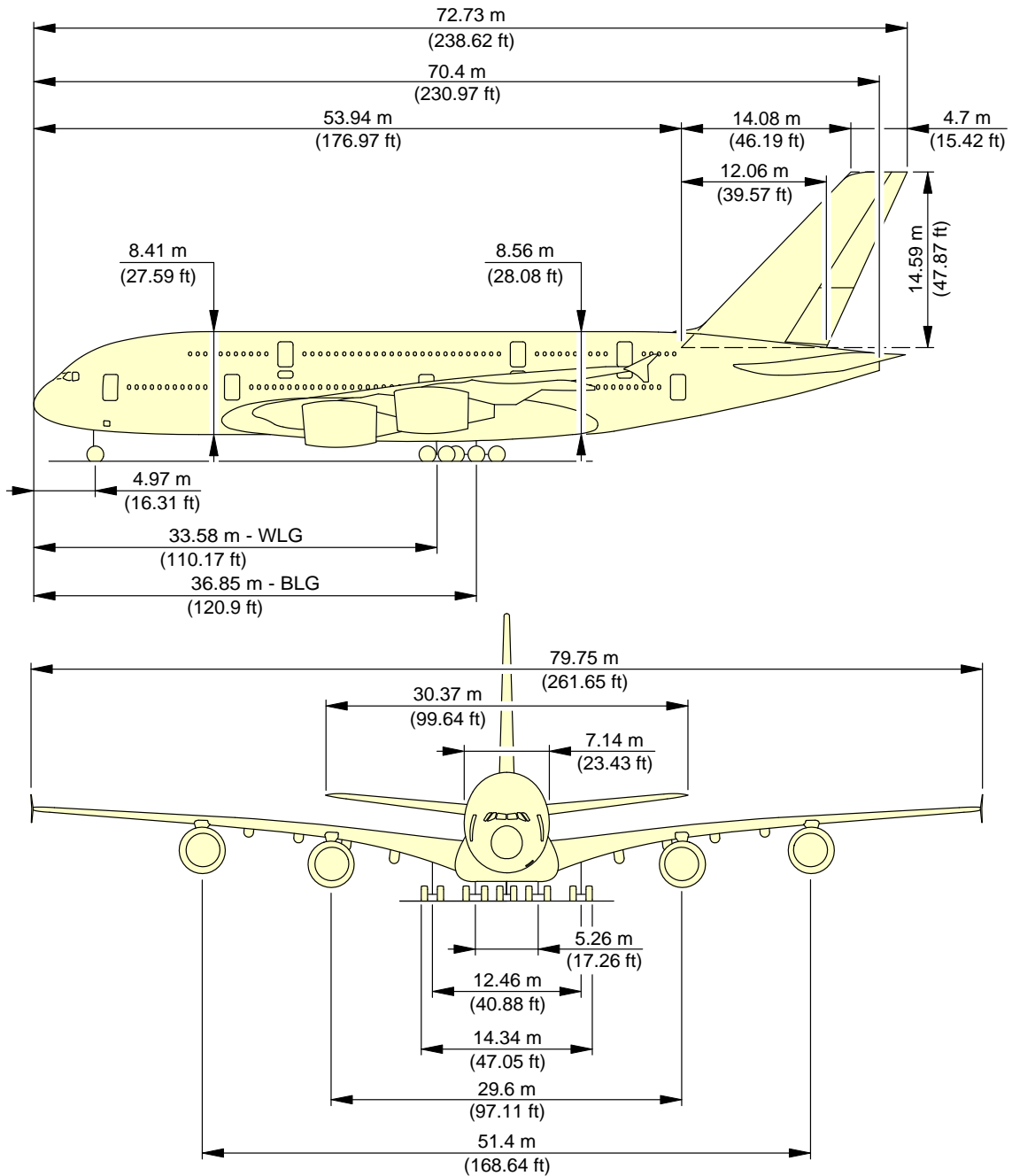

NOTE: RELATED TO AIRCRAFT ATTITUDE AND WEIGHT.

L_AC_020200_1_0010101_01_02

General Aircraft Dimensions
(Sheet 1 of 2)
FIGURE-2-2-0-991-001-A01

****ON A/C A380-800**

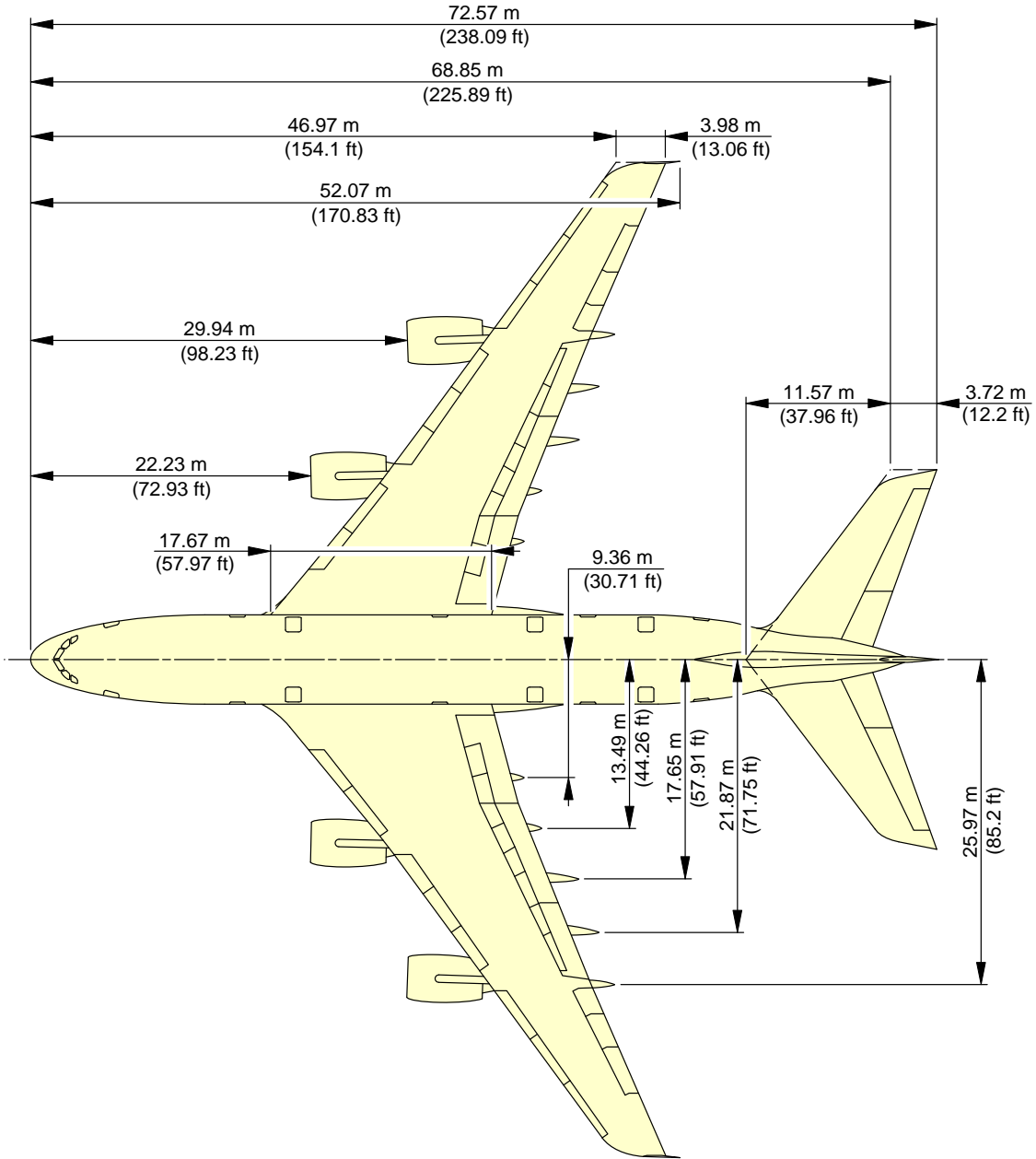

NOTE: RELATED TO AIRCRAFT ATTITUDE AND WEIGHT.

L_AC_020200_1_0010103_01_00

General Aircraft Dimensions
(Sheet 2 of 2)
FIGURE-2-2-0-991-001-A01

2-3-0 Ground Clearances****ON A/C A380-800**Ground Clearances

1. This section provides the heights of various points of the aircraft, above the ground, for different aircraft configurations.

Dimensions in the tables are approximate and will vary with tire type, weight and balance and other special conditions.

The dimensions are given for:

- A light weight, for an aircraft in maintenance configuration with a FWD CG and an AFT CG,
- An aircraft at Maximum Ramp Weight with a FWD CG and an AFT CG,
- Aircraft on jacks, FDL at 7.20 m (23.62 ft).

NOTE : Passenger and cargo door ground clearances are measured from the center of the door sill and from floor level.

****ON A/C A380-800**

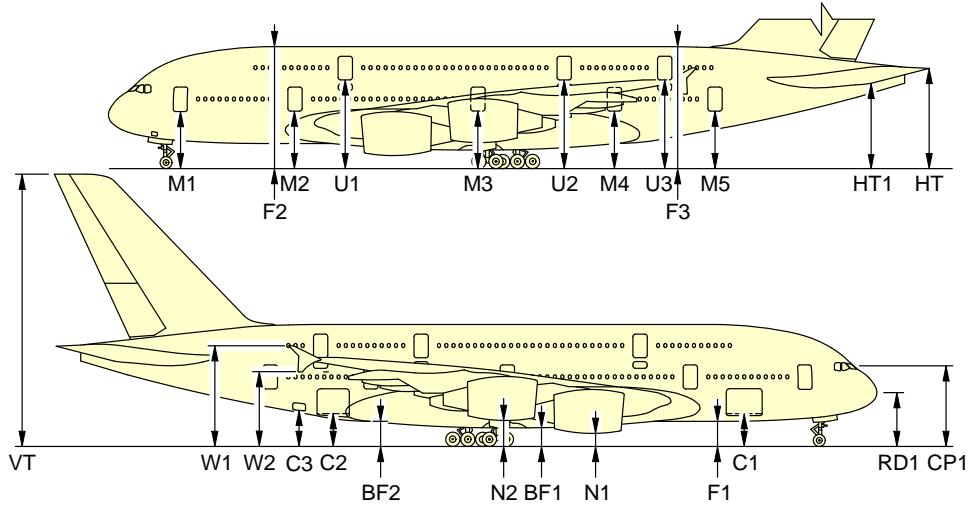

A/C CONFIGURATION		MRW				300 t				A/C JACKED FDL = 7.20 m (23.6 ft)	
		FWD CG (37.8%)		AFT CG (41%)		FWD CG (29%)		AFT CG (44%)			
		m	ft	m	ft	m	ft	m	ft		
DOORS	M1	5.10	16.7	5.13	16.8	5.14	16.9	5.36	17.6	7.15	23.5
	M2	5.12	16.8	5.14	16.9	5.20	17.1	5.34	17.5	7.15	23.5
	M3	5.15	16.9	5.15	16.9	5.30	17.4	5.31	17.4	7.15	23.5
	M4	5.18	17.0	5.15	16.9	5.37	17.6	5.28	17.3	7.15	23.5
	M5	5.20	17.1	5.16	16.9	5.42	17.8	5.27	17.3	7.15	23.5
	U1	7.87	25.8	7.89	25.9	7.98	26.2	8.08	26.5	9.90	32.5
	U2	7.91	26.0	7.90	25.9	8.10	26.6	8.04	26.4	9.90	32.5
	U3	7.94	26.0	7.91	26.0	8.15	26.7	8.02	26.3	9.90	32.5
	C1	3.05	10.0	3.08	10.1	3.24	10.6	3.30	10.8	5.12	16.8
C2	3.11	10.2	3.10	10.2	3.27	10.7	3.23	10.6	5.12	16.8	
C3	3.24	10.6	3.23	10.6	3.41	11.2	3.36	11.0	5.24	17.2	
FUSELAGE	F1	2.34	7.7	2.38	7.8	2.45	8.0	2.59	8.5	4.41	14.5
	F2	10.75	35.3	10.79	35.4	10.84	35.6	11.00	36.1	12.82	42.1
	F3	10.83	35.5	10.78	35.4	10.97	36.0	10.93	35.9	12.82	42.1
	BF1	1.66	5.4	1.66	5.4	1.82	6.0	1.82	6.0	3.68	12.1
	BF2	2.27	7.4	2.22	7.3	2.41	7.9	2.38	7.8	4.27	14.0
	CP1	7.13	23.4	7.17	23.5	7.16	23.5	7.42	24.3	9.22	30.2
WINGS	RD1	4.74	15.6	4.82	15.8	4.76	15.6	5.02	16.5	6.84	22.4
	W1	7.55	24.8	7.49	24.6	8.27	27.1	8.22	27.0	10.12	33.2
TAILPLANE	W2	5.27	17.3	5.21	17.1	5.97	19.6	5.94	19.5	7.84	25.7
	HT	9.20	30.2	9.15	30.0	9.30	30.5	9.20	30.2	11.14	36.5
	HT1	7.65	25.1	7.60	24.9	7.75	25.4	7.65	25.1	9.59	31.5
ENGINE/ NACELLE	VT	24.17	79.3	24.12	79.1	24.27	79.6	24.17	79.3	26.11	85.7
	N1	1.05	3.4	1.08	3.5	1.30	4.3	1.30	4.3	3.14	10.3
	N2	1.90	6.2	1.90	6.2	2.27	7.4	2.27	7.4	4.13	13.5

NOTE:

- PASSENGER AND CARGO DOOR GROUND CLEARANCES ARE MEASURED FROM THE CENTER OF THE DOOR SILL AND FROM FLOOR LEVEL.

- MAXIMUM JACKING WEIGHT = 333 700 kg (735 682 lb).

L_AC_020300_1_0010101_01_04

Ground Clearances
FIGURE-2-3-0-991-001-A01

****ON A/C A380-800**

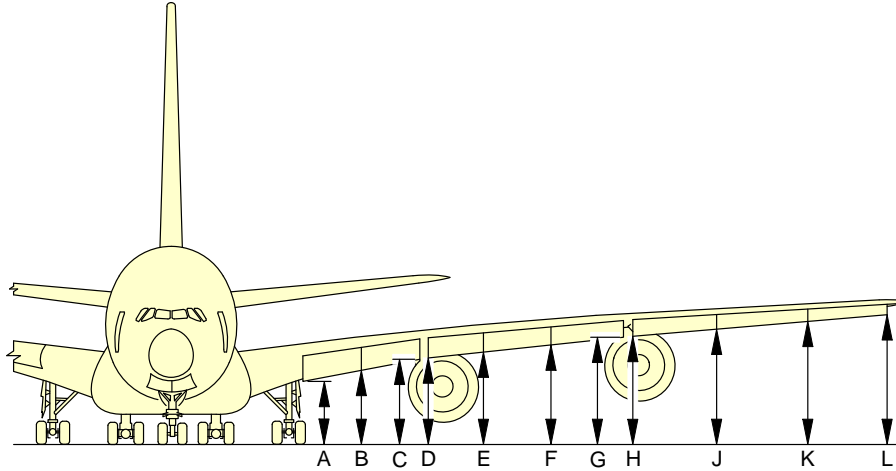

LEADING EDGE SLATS EXTENDED							
DESCRIPTION		MRW FWD CG		MRW AFT CG		300 t MID CG	
		m	ft	m	ft	m	ft
DN1* INBD END	A	3.95	13.0	3.98	13.1	4.10	13.5
DN1/DN2*	B	4.60	15.1	4.62	15.2	4.78	15.7
DN2* OUTBD END	C	5.12	16.8	5.13	16.8	5.32	17.5
SLAT 2 INBD END	D	5.12	16.8	5.13	16.8	5.35	17.6
SLAT 2/3	E	5.34	17.5	5.35	17.6	5.61	18.4
SLAT 3/4	F	5.53	18.1	5.53	18.1	5.85	19.2
SLAT 4 OUTBD END	G	5.65	18.5	5.65	18.5	6.04	19.8
SLAT 5 INBD END	H	5.78	19.0	5.77	18.9	6.21	20.4
SLAT 5/6	J	5.89	19.3	5.87	19.3	6.40	21.0
SLAT 6/7	K	5.98	19.6	5.96	19.6	6.58	21.6
SLAT 7 OUTBD END	L	6.05	19.8	6.02	19.8	6.75	22.1

NOTE:

* DN - DROOP NOSE

L_AC_020300_1_0040101_01_01

Ground Clearances
 Leading Edge Slats - Extended
 FIGURE-2-3-0-991-004-A01

****ON A/C A380-800**

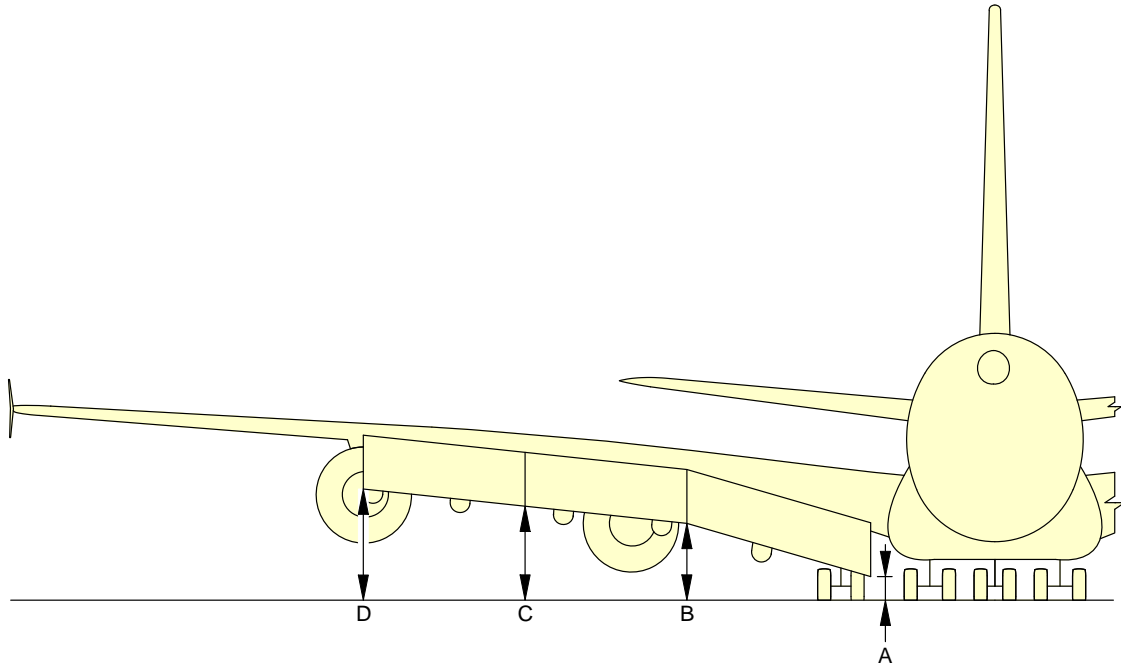

FLAPS EXTENDED							
DESCRIPTION		MRW FWD CG		MRW AFT CG		300 t MID CG	
		m	ft	m	ft	m	ft
INNER END	A	1.54	5.1	1.53	5.0	1.71	5.6
INNER/MID	B	3.43	11.3	3.42	11.2	3.66	12.0
MID OUTER	C	4.56	15.0	4.54	14.9	4.92	16.1
OUTER END	D	5.11	16.8	5.08	16.7	5.61	18.4

L_AC_020300_1_0050101_01_01

Ground Clearances
Trailing Edge Flaps - Extended
FIGURE-2-3-0-991-005-A01

****ON A/C A380-800**

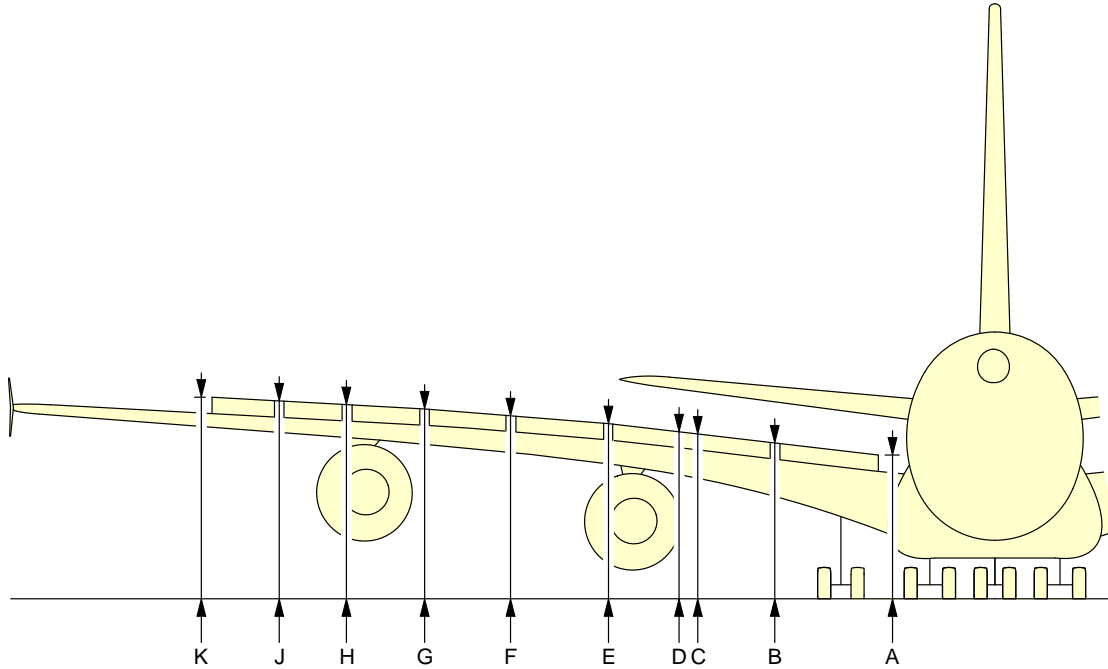

SPOILERS EXTENDED							
DESCRIPTION		MRW FWD CG		MRW AFT CG		300 t MID CG	
		m	ft	m	ft	m	ft
SPOILER 1 INBD	A	4.98	16.3	4.97	16.3	5.17	17.0
SPOILER 1/2	B	5.62	18.4	5.61	18.4	5.81	19.1
SPOILER 2 OUTBD END	C	6.09	20.0	6.08	19.9	6.31	20.7
SPOILER 3	D	6.32	20.7	6.31	20.7	6.55	21.5
SPOILER 3/4	E	6.56	21.5	6.55	21.5	6.80	22.3
SPOILER 4/5	F	6.79	22.3	6.78	22.2	7.07	23.2
SPOILER 5/6	G	6.94	22.8	6.93	22.7	7.25	23.8
SPOILER 6/7	H	7.02	23.0	7.00	23.0	7.36	24.1
SPOILER 7/8	J	7.02	23.0	7.00	23.0	7.42	24.3
SPOILER 8 OUTBD END	K	7.00	23.0	6.98	22.9	7.45	24.4

L_AC_020300_1_0060101_01_00

Ground Clearances
Spoilers - Extended
FIGURE-2-3-0-991-006-A01

****ON A/C A380-800**

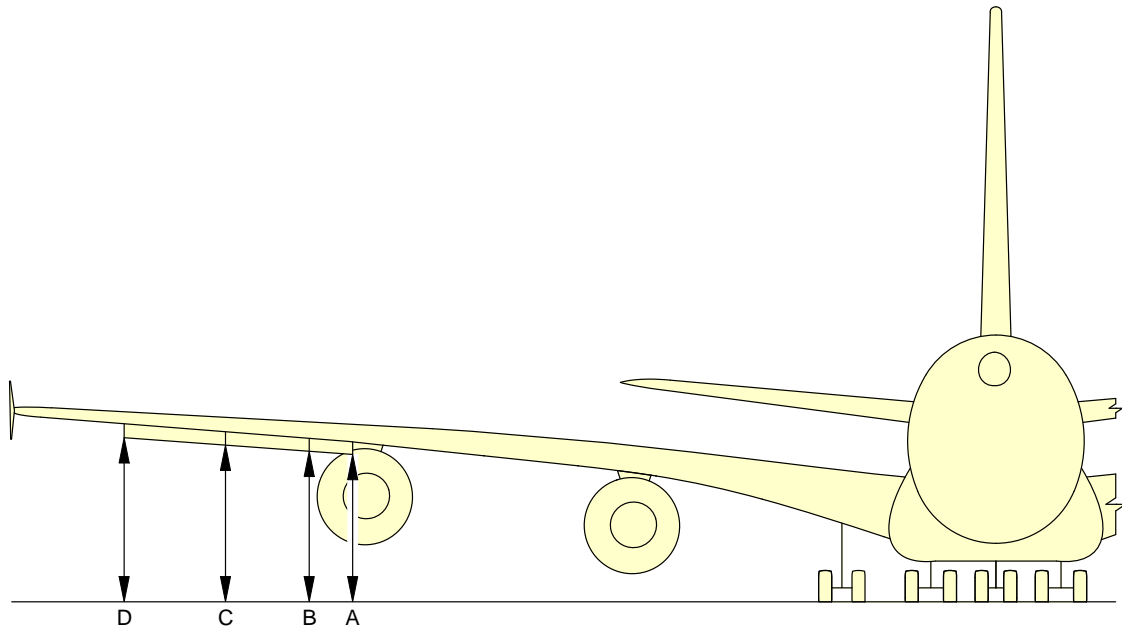

AILERONS DOWN							
DESCRIPTION		MRW FWD CG		MRW AFT CG		300 t MID CG	
		m	ft	m	ft	m	ft
INNER END	A	5.83	19.1	5.80	19.0	6.32	20.7
INNER/MID	B	5.90	19.4	5.87	19.3	6.43	21.1
MID OUTER	C	5.99	19.7	5.96	19.6	6.58	21.6
OUTER END	D	6.12	20.1	6.08	19.9	6.78	22.2

L_AC_020300_1_0070101_01_01

Ground Clearances
Ailerons - Down
FIGURE-2-3-0-991-007-A01

****ON A/C A380-800**

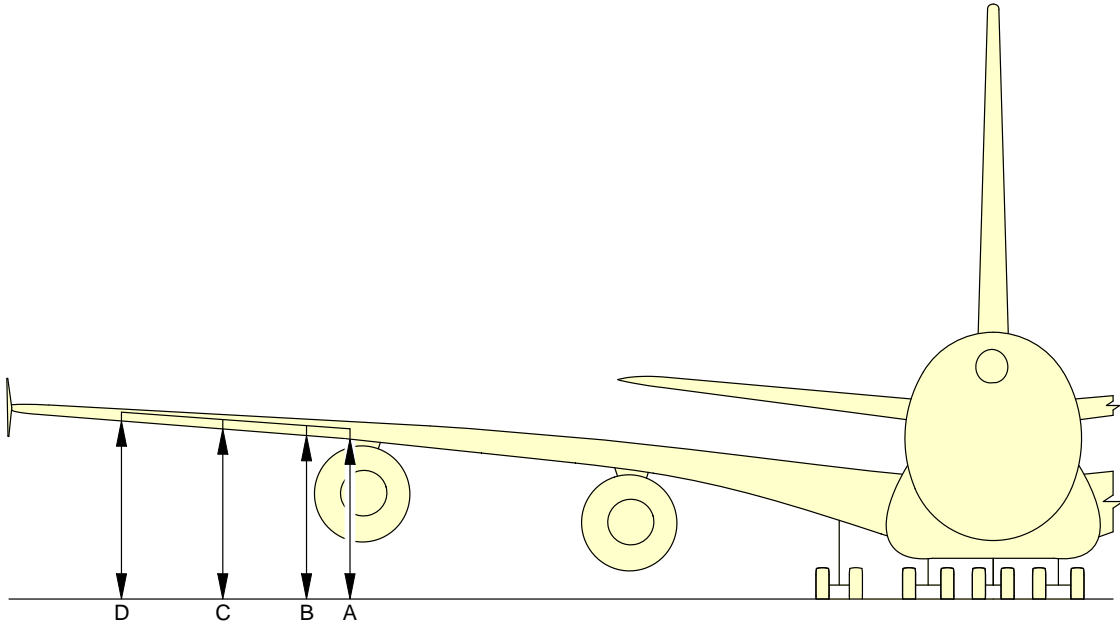

AILERONS UP							
DESCRIPTION		MRW FWD CG		MRW AFT CG		300 t MID CG	
		m	ft	m	ft	m	ft
INNER END	A	6.38	20.9	6.35	20.8	6.87	22.5
INNER/MID	B	6.41	21.0	6.38	20.9	6.94	22.8
MID OUTER	C	6.45	21.2	6.41	21.0	7.04	23.1
OUTER END	D	6.50	21.3	6.46	21.2	7.17	23.5

L_AC_020300_1_0080101_01_01

Ground Clearances
Ailerons - Up
FIGURE-2-3-0-991-008-A01

****ON A/C A380-800**

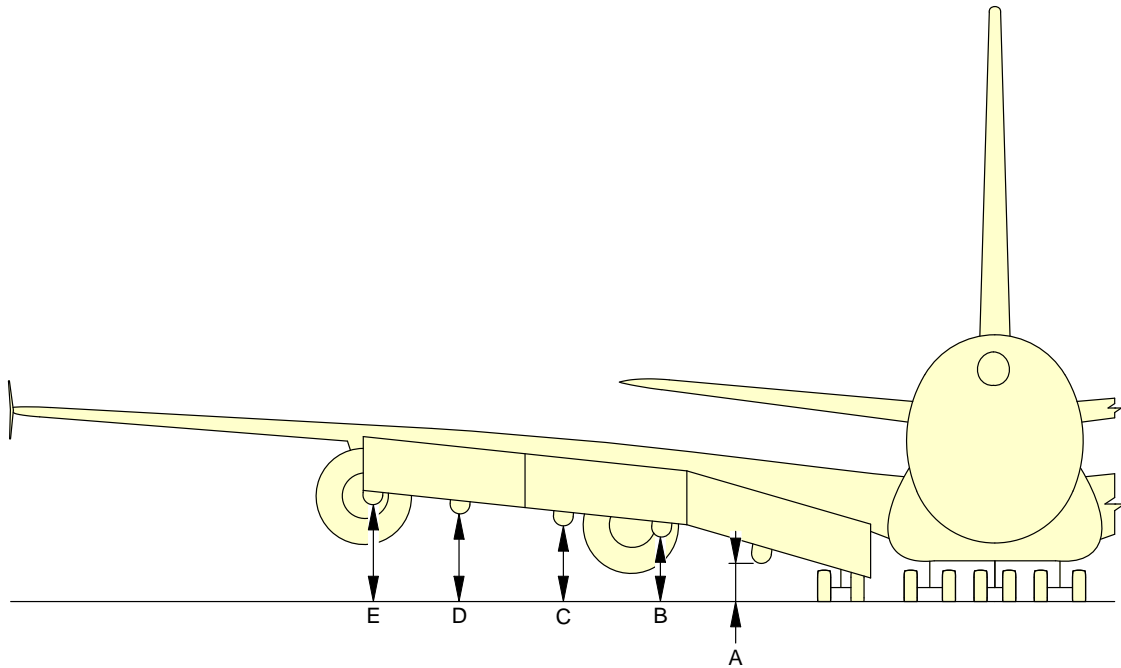

FLAP TRACKS EXTENDED							
DESCRIPTION		MRW FWD CG		MRW AFT CG		300 t MID CG	
		m	ft	m	ft	m	ft
TRACK 2	A	2.17	7.1	2.15	7.1	2.37	7.8
TRACK 3	B	2.87	9.4	2.85	9.4	3.12	10.2
TRACK 4	C	3.08	10.1	3.06	10.0	3.42	11.2
TRACK 5	D	3.48	11.4	3.45	11.3	3.89	12.8
TRACK 6	E	3.86	12.7	3.82	12.5	4.35	14.3

L_AC_020300_1_0090101_01_01

Ground Clearances
Flap Tracks - Extended
FIGURE-2-3-0-991-009-A01

****ON A/C A380-800**

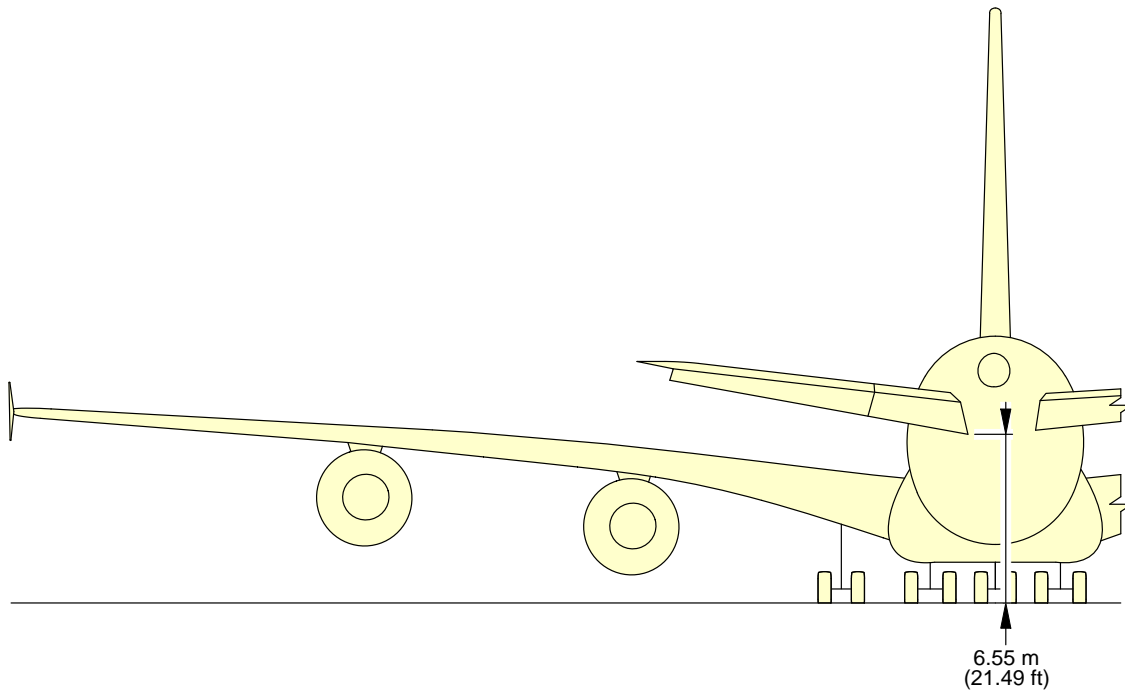

NOTE:
TRIMMABLE HORIZONTAL STABILIZER AND ELEVATORS
ARE IN FULLY DOWN POSITION.

L_AC_020300_1_0100101_01_00

Ground Clearances
Trimmable Horizontal Stabilizer and Elevators - Down
FIGURE-2-3-0-991-010-A01

2-4-0 Interior Arrangement - Plan View****ON A/C A380-800**Interior Arrangement - Plan View

1. This section provides the standard configuration.

****ON A/C A380-800**

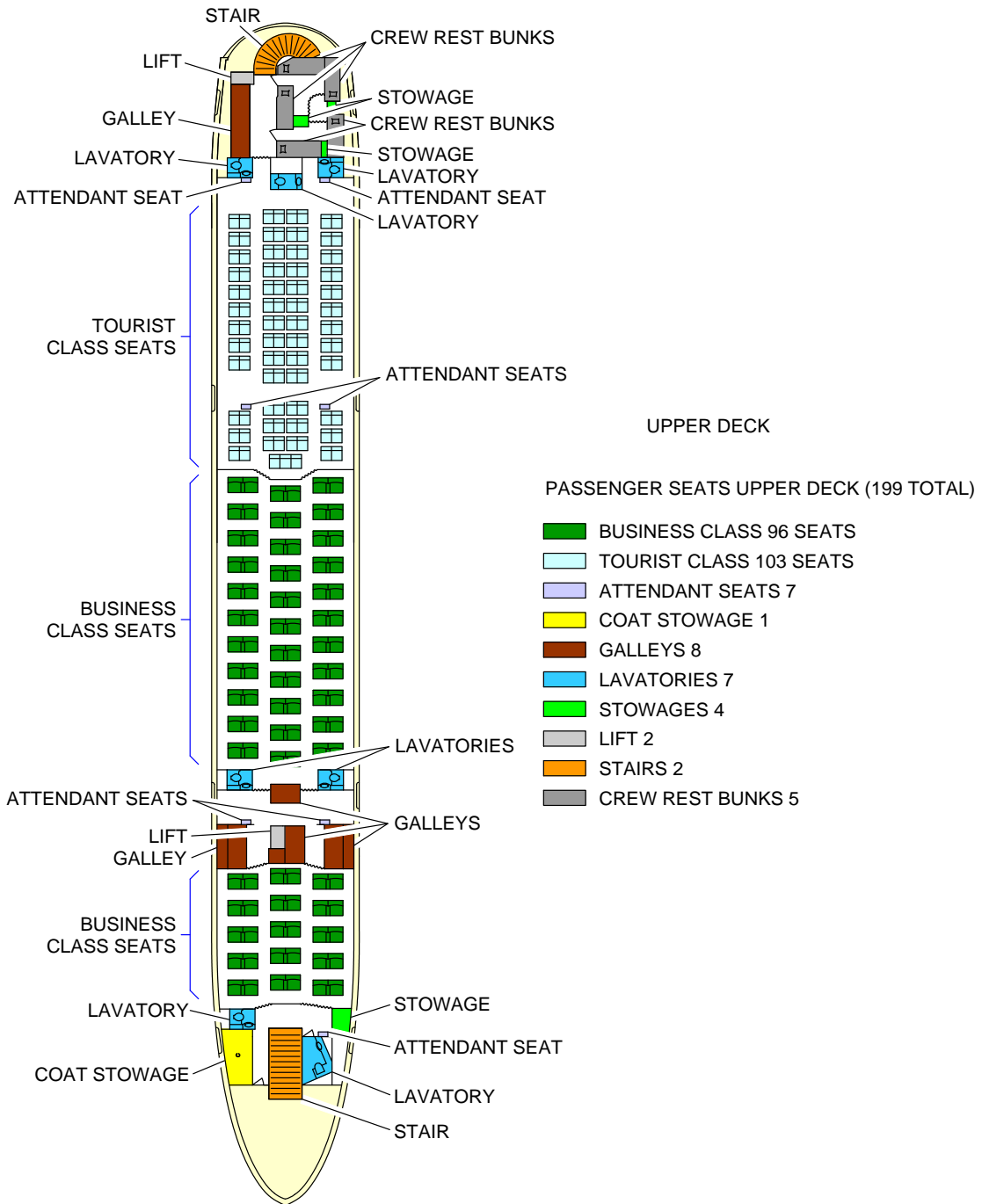

L_AC_020400_1_0010101_01_00

Interior Arrangements - Plan View
 Standard Configuration - Upper Deck
 FIGURE-2-4-0-991-001-A01

****ON A/C A380-800**

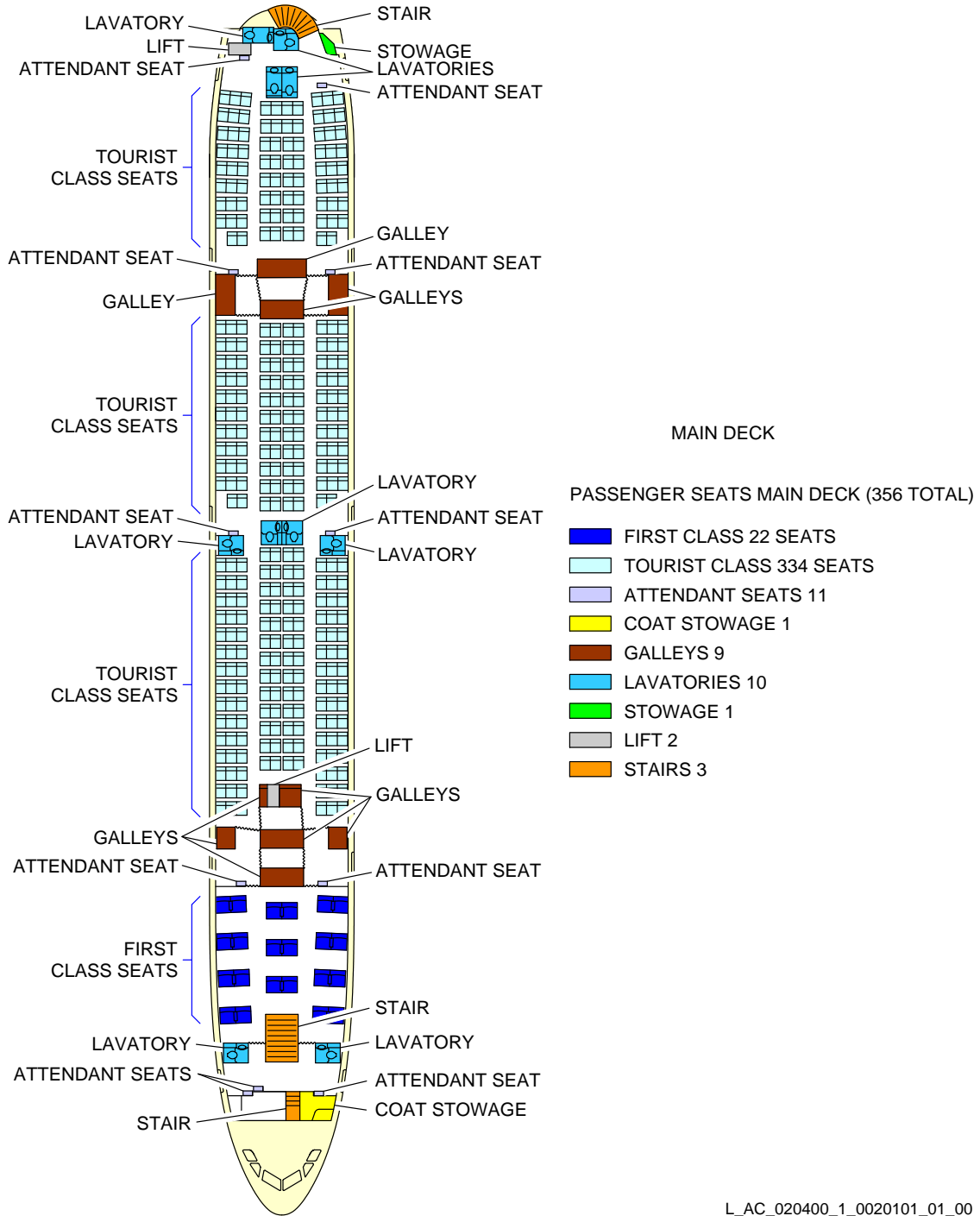

L_AC_020400_1_0020101_01_00

Interior Arrangements - Plan View
 Standard Configuration - Main Deck
 FIGURE-2-4-0-991-002-A01

2-5-0 Interior Arrangements - Cross Section

****ON A/C A380-800**

Interior Arrangements - Cross Section

1. This section provides the typical configuration.

****ON A/C A380-800**

UPPER DECK
TOURIST CLASS 8 ABREAST

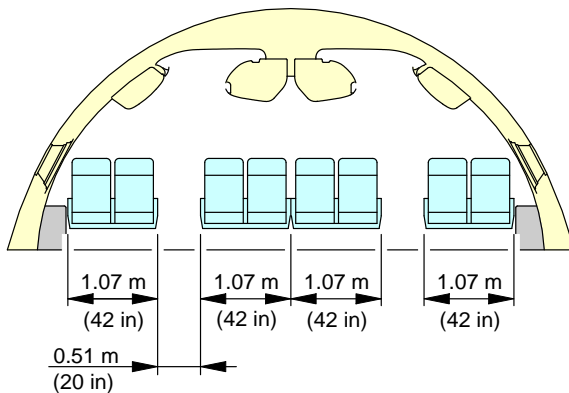

UPPER DECK
BUSINESS CLASS 6 ABREAST

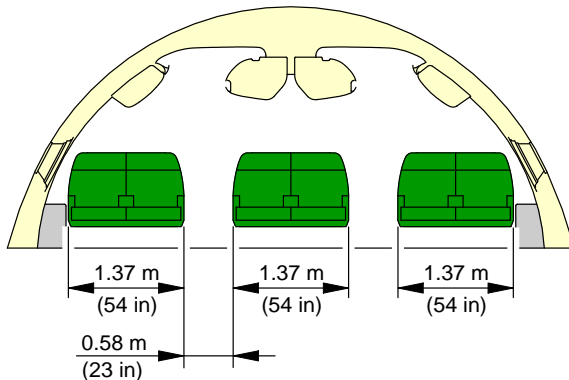

L_AC_020500_1_0010101_01_00

Interior Arrangements - Cross Section
Typical Configuration - Upper Deck
FIGURE-2-5-0-991-001-A01

****ON A/C A380-800**

MAIN DECK
TOURIST CLASS 10 ABREAST

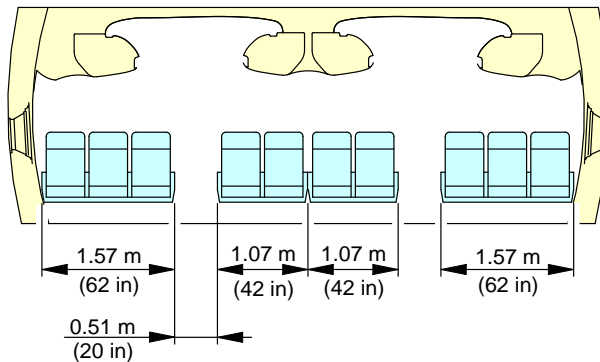

MAIN DECK
FIRST CLASS 6 ABREAST

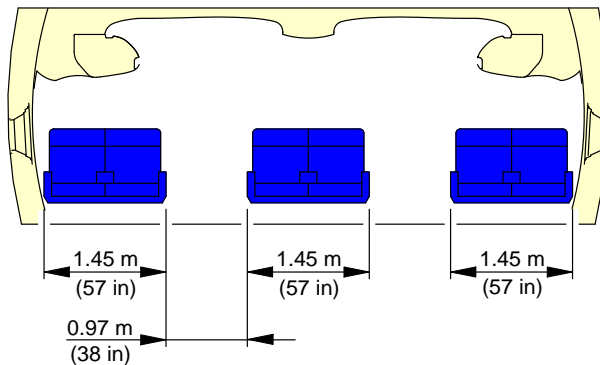

L_AC_020500_1_0020101_01_00

Interior Arrangements - Cross Section
Typical Configuration - Main Deck
FIGURE-2-5-0-991-002-A01

2-6-0 Cargo Compartments****ON A/C A380-800**Cargo Compartments

1. This section provides cargo compartments:
 - Location and dimensions
 - Loading combinations.

****ON A/C A380-800**

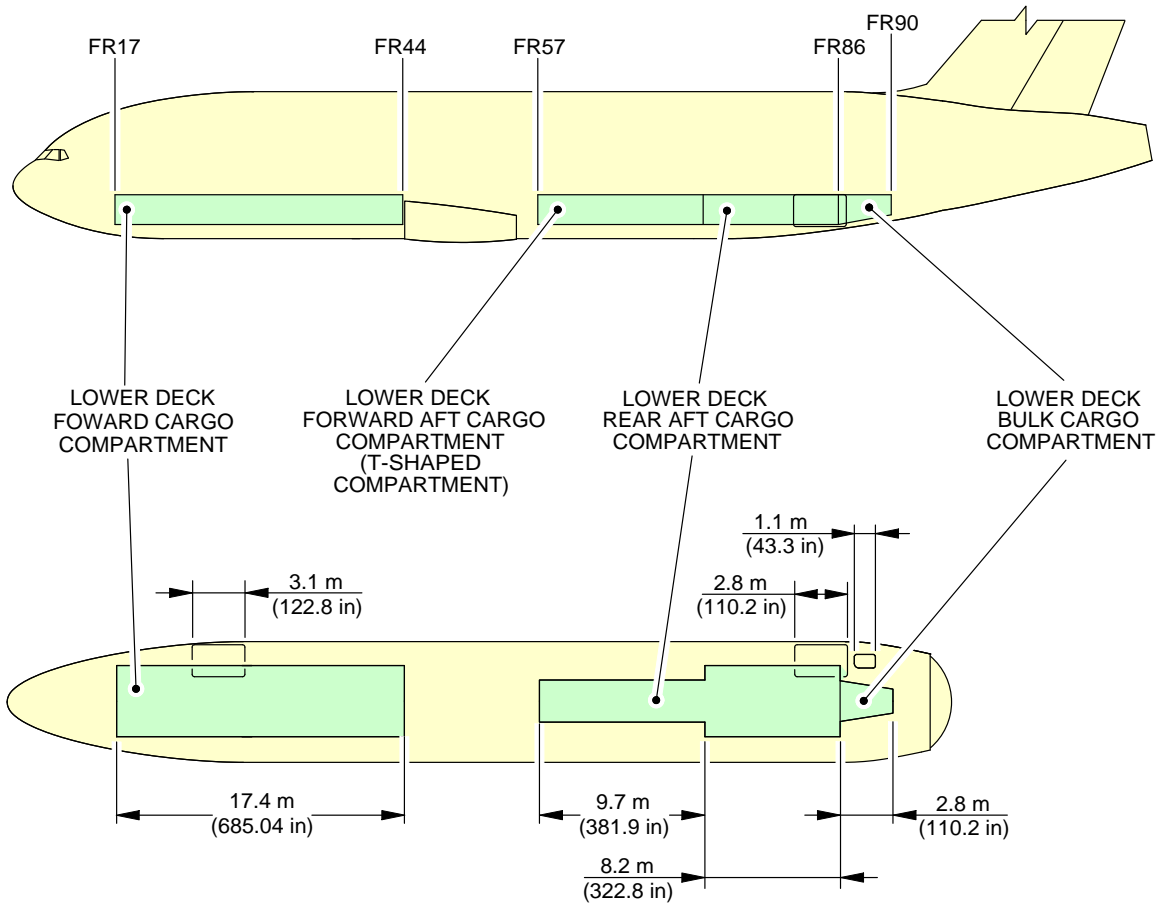

L_AC_020600_1_0010101_01_01

Cargo Compartments
Location and Dimensions
FIGURE-2-6-0-991-001-A01

****ON A/C A380-800**

STANDARD: 20 LD3 OR 7 PALLETS 88 in / 96 in X 125 in
OPTION: 22 LD3 OR 7 PALLETS 88 in / 96 in X 125 in

STANDARD: 16 LD3 OR 6 LD3 3 PALLETS 88 in / 96 in X 125 in
OPTION: 6 PALLETS 88 in / 96 in X 125 in

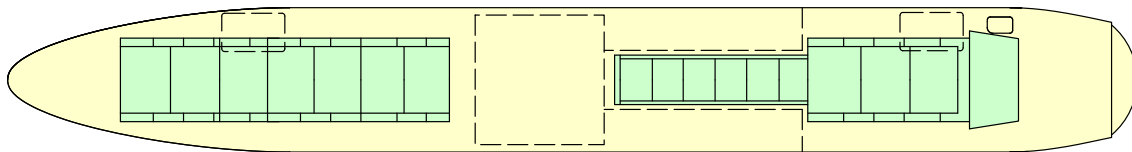

L_AC_020600_1_0020101_01_01

Cargo Compartments
Loading Combinations
FIGURE-2-6-0-991-002-A01

2-7-0 Door Clearances

****ON A/C A380-800**

Door Clearances

1. This section provides door clearances and location.

****ON A/C A380-800**

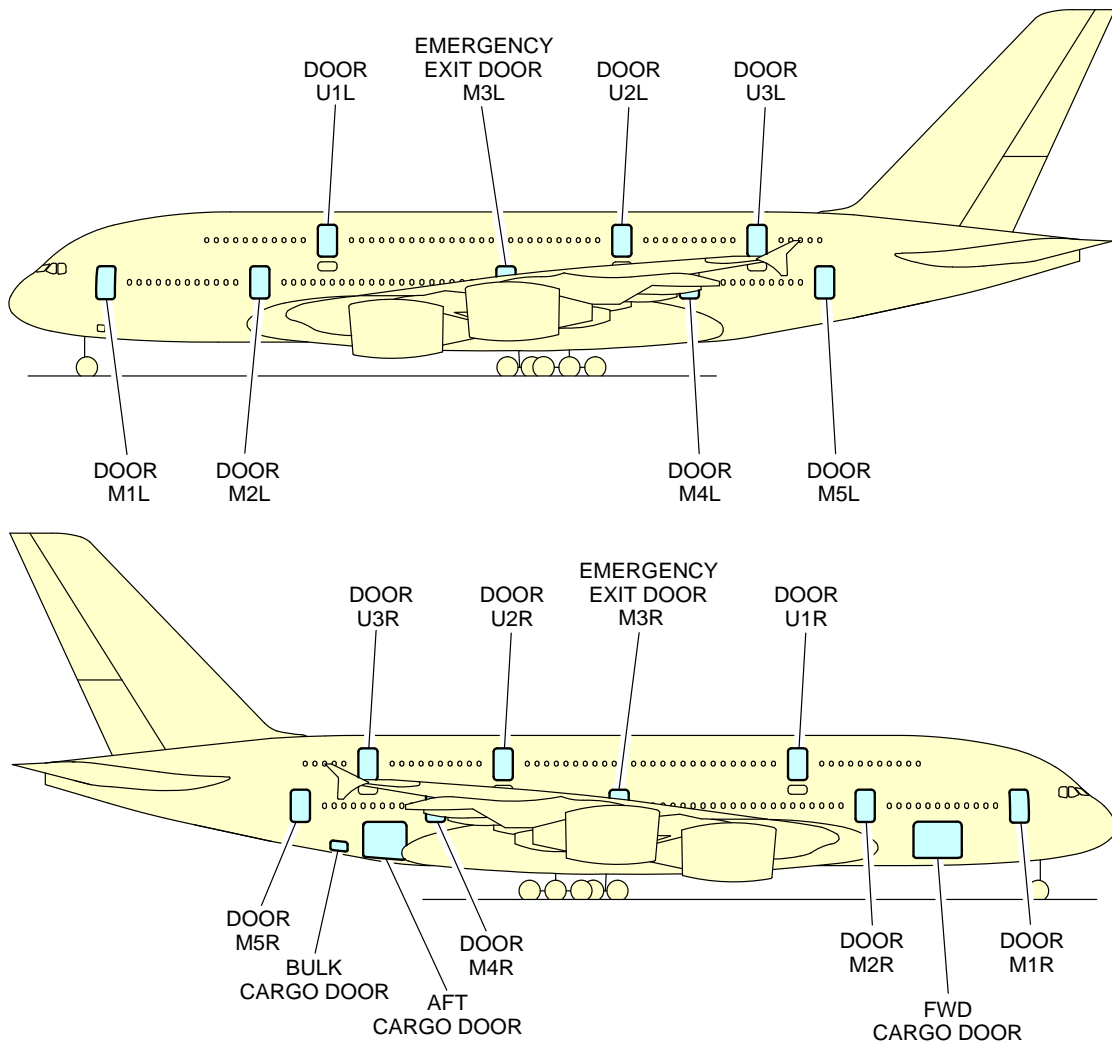

L_AC_020700_1_0010101_01_01

Door Clearances
Door Location (Sheet 1)
FIGURE-2-7-0-991-001-A01

****ON A/C A380-800**

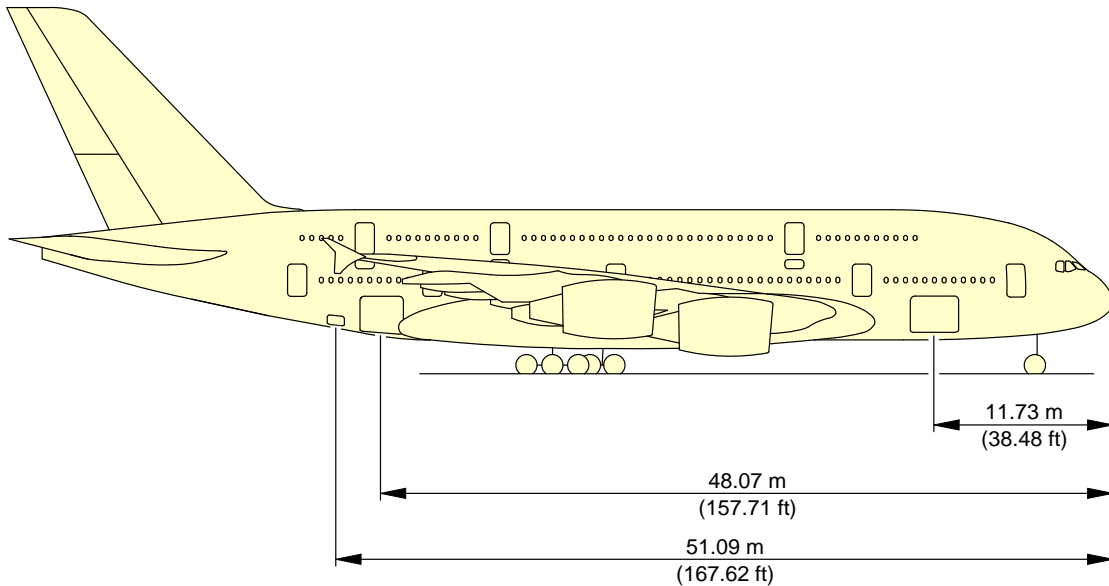
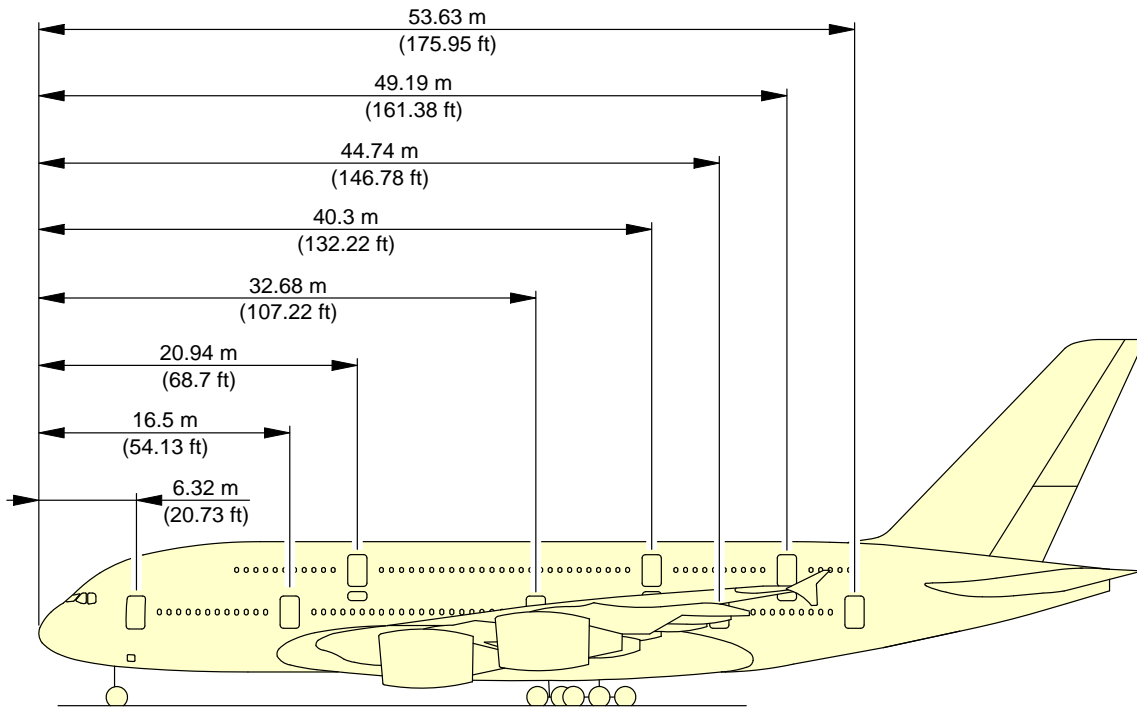

L_AC_020700_1_0020101_01_01

Door Clearances
Door Location (Sheet 2)
FIGURE-2-7-0-991-002-A01

****ON A/C A380-800**

MAIN DECK DOORS M1L, M1R

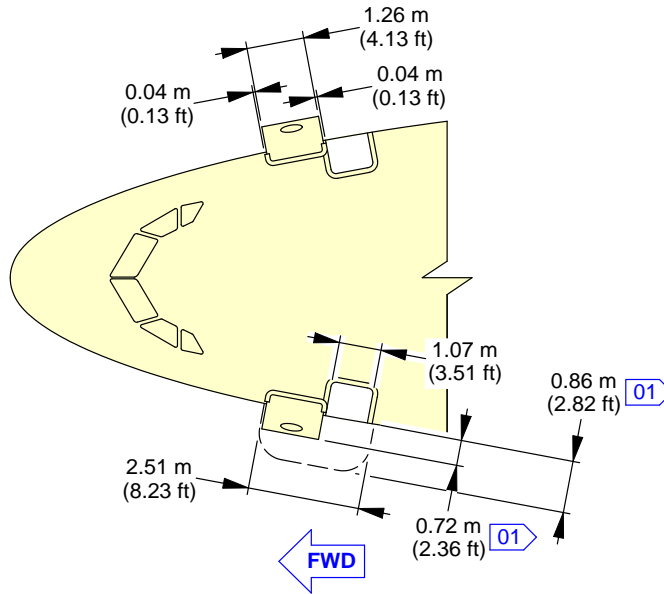
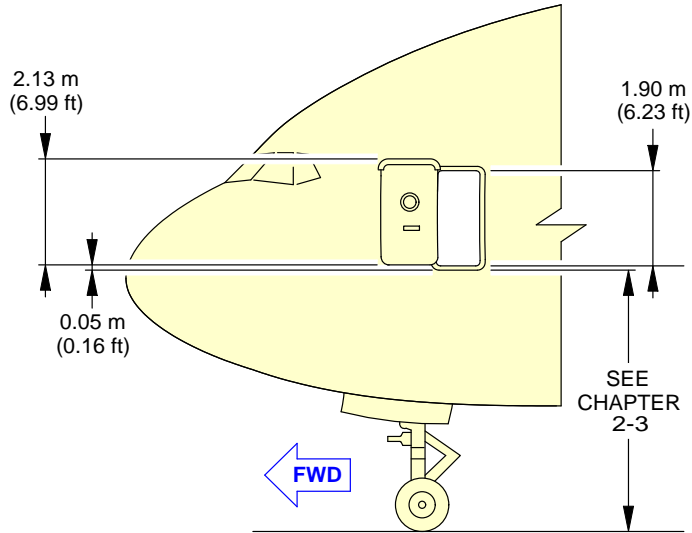

NOTE:

01 MEASURED FROM THE EXTERNAL POINT OF THE SCUFF PLATE AND THE MOST EXTERNAL POINT OF THE DOOR SKIN.

L_AC_020700_1_0050101_01_01

Door Clearances
Forward Passenger Doors
FIGURE-2-7-0-991-005-A01

****ON A/C A380-800**

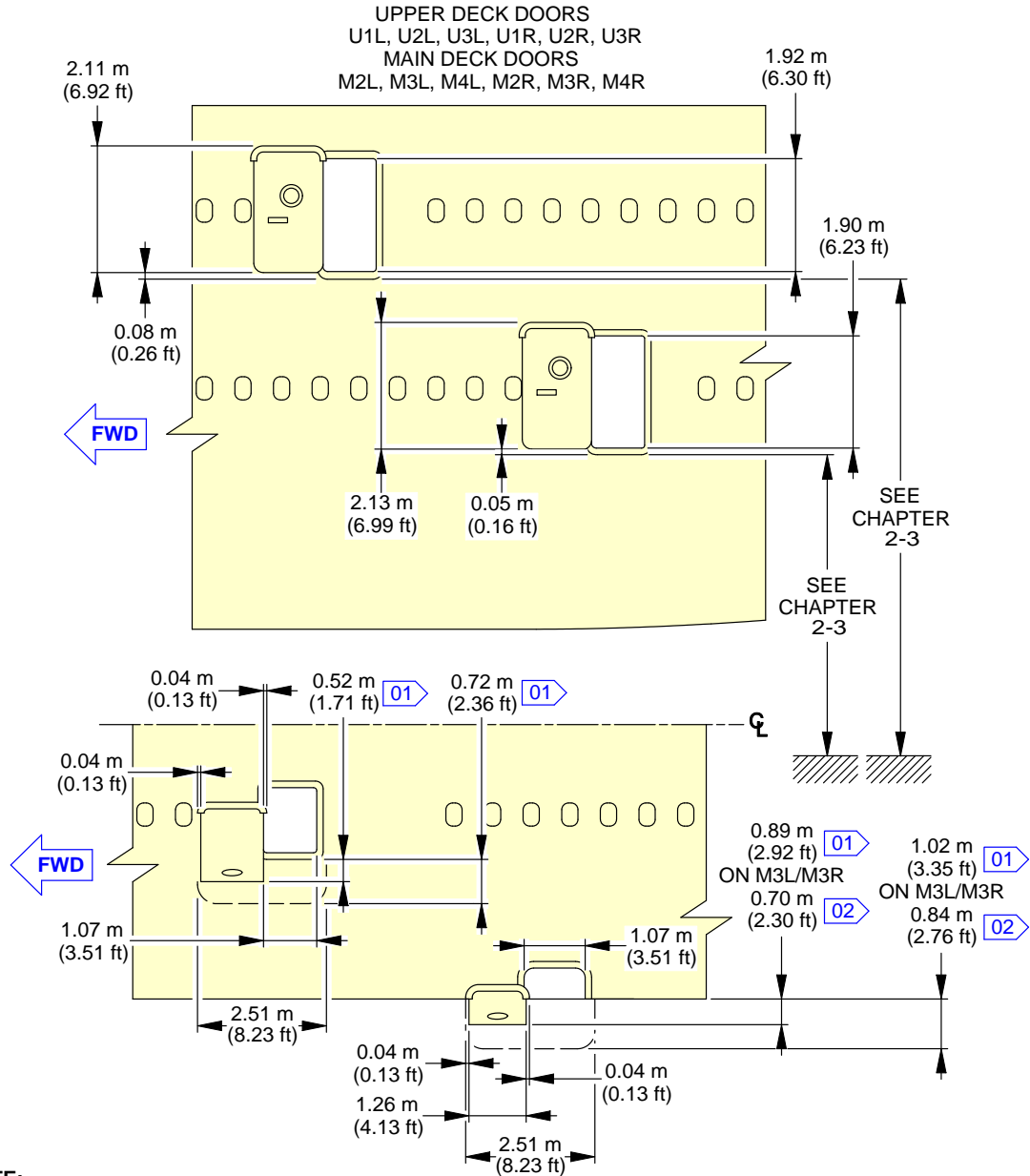

NOTE:

- 01 MEASURED FROM THE EXTERNAL POINT OF THE SCUFF PLATE AND THE MOST EXTERNAL POINT OF THE DOOR SKIN.
- 02 ON DOOR M3L/M3R MEASURED FROM THE EXTERNAL POINT OF THE CUTOUT IN THE BELLY FAIRING AND THE MOST EXTERNAL POINT OF THE BELLY FAIRING FROM THE DOOR.

L_AC_020700_1_0060101_01_01

Door Clearances
Main and Upper Deck Passenger Doors
FIGURE-2-7-0-991-006-A01

****ON A/C A380-800**

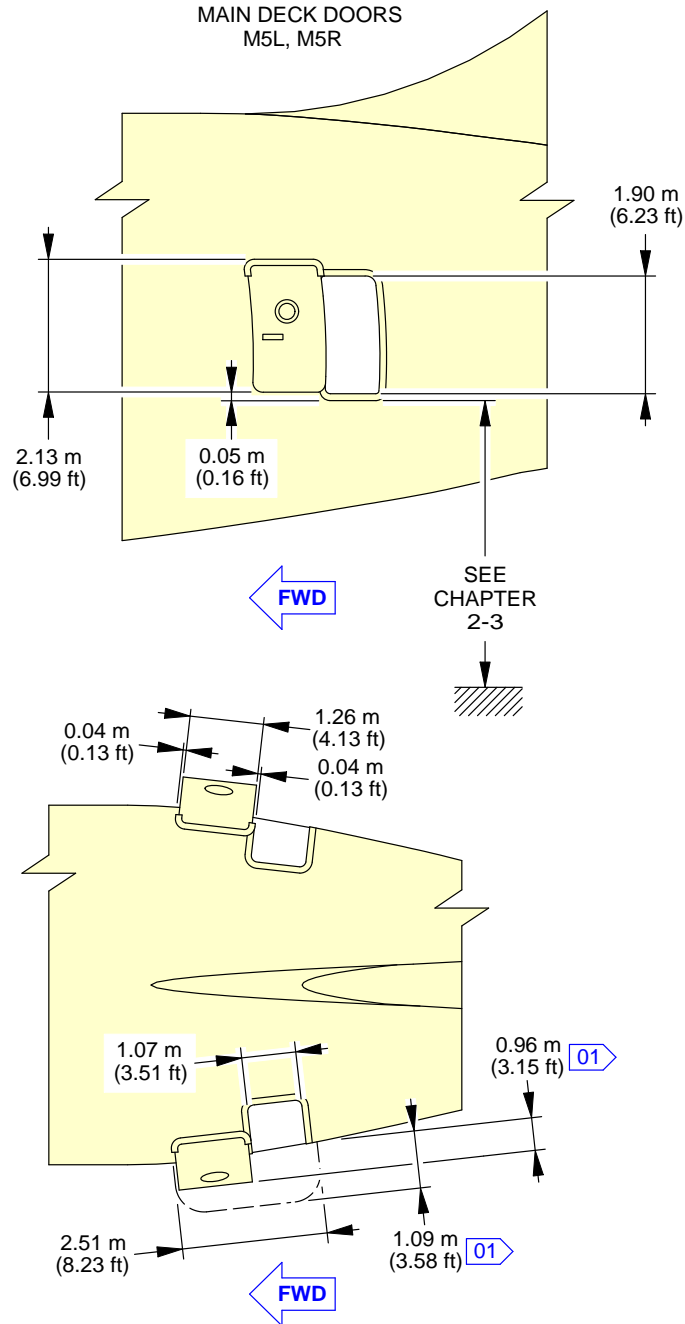

NOTE:

01 MEASURED FROM THE EXTERNAL POINT OF THE SCUFF PLATE AND THE MOST EXTERNAL POINT OF THE DOOR SKIN.

L_AC_020700_1_0070101_01_01

Door Clearances
Aft Passenger Doors
FIGURE-2-7-0-991-007-A01

****ON A/C A380-800**

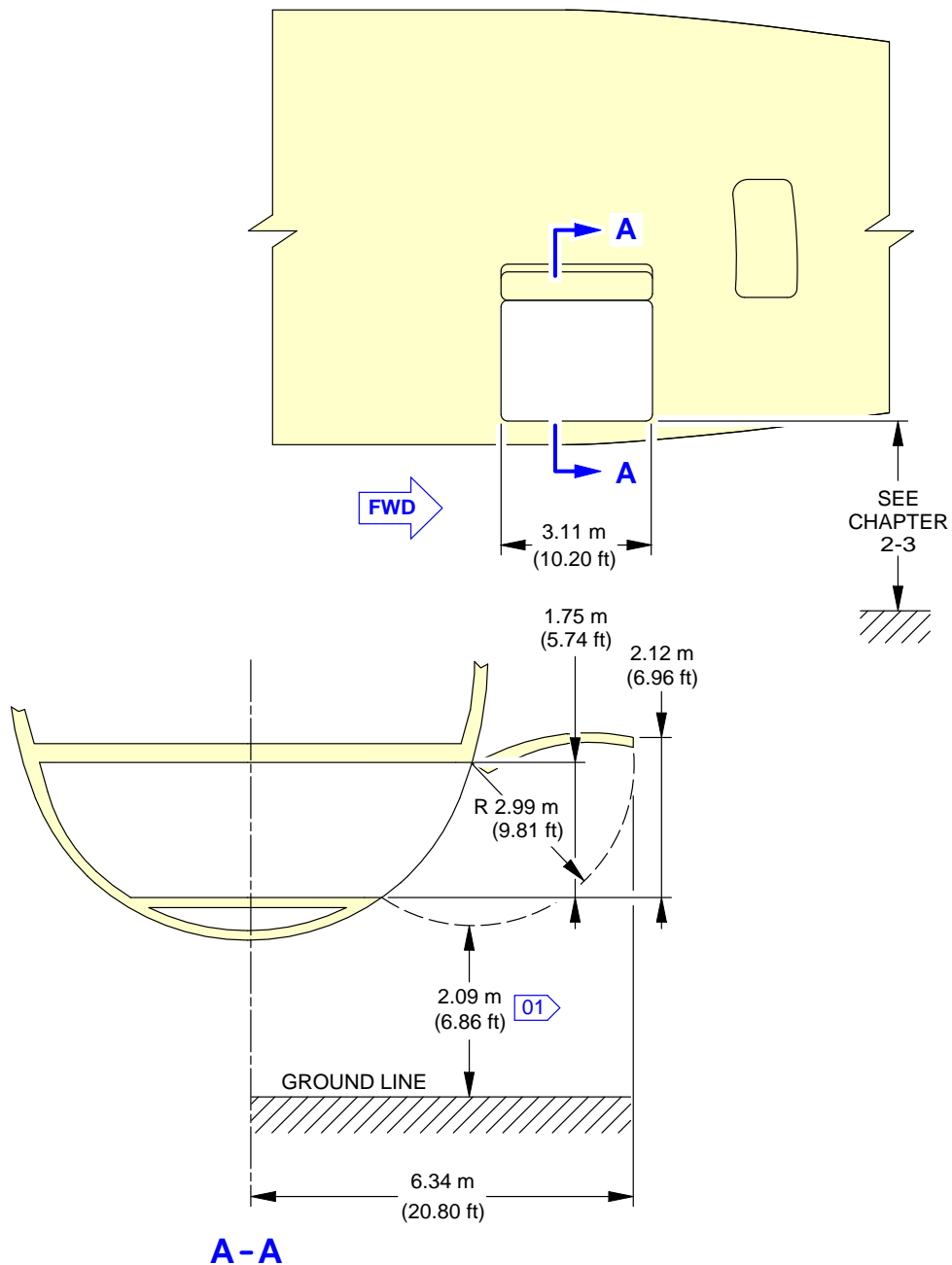

NOTE:
01 DEPENDING ON CG POSITION AND AIRCRAFT WEIGHT.

L_AC_020700_1_0080101_01_01

Door Clearances
 Forward Cargo Compartment Door
 FIGURE-2-7-0-991-008-A01

****ON A/C A380-800**

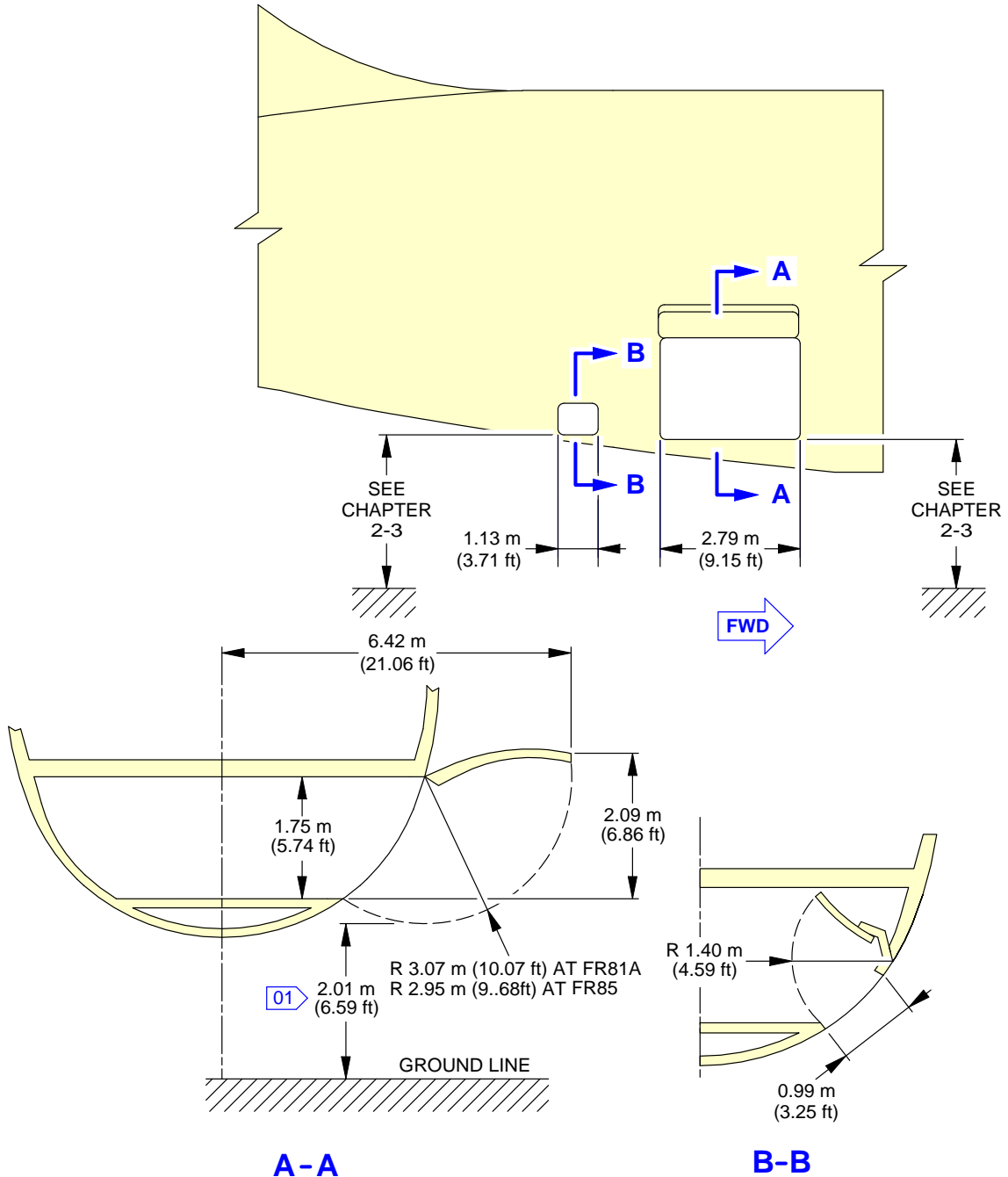

NOTE:
 01 DEPENDING ON CG POSITION AND AIRCRAFT WEIGHT.

L_AC_020700_1_0090101_01_01

Door Clearances
 Aft Cargo Compartment Doors
 FIGURE-2-7-0-991-009-A01

****ON A/C A380-800**

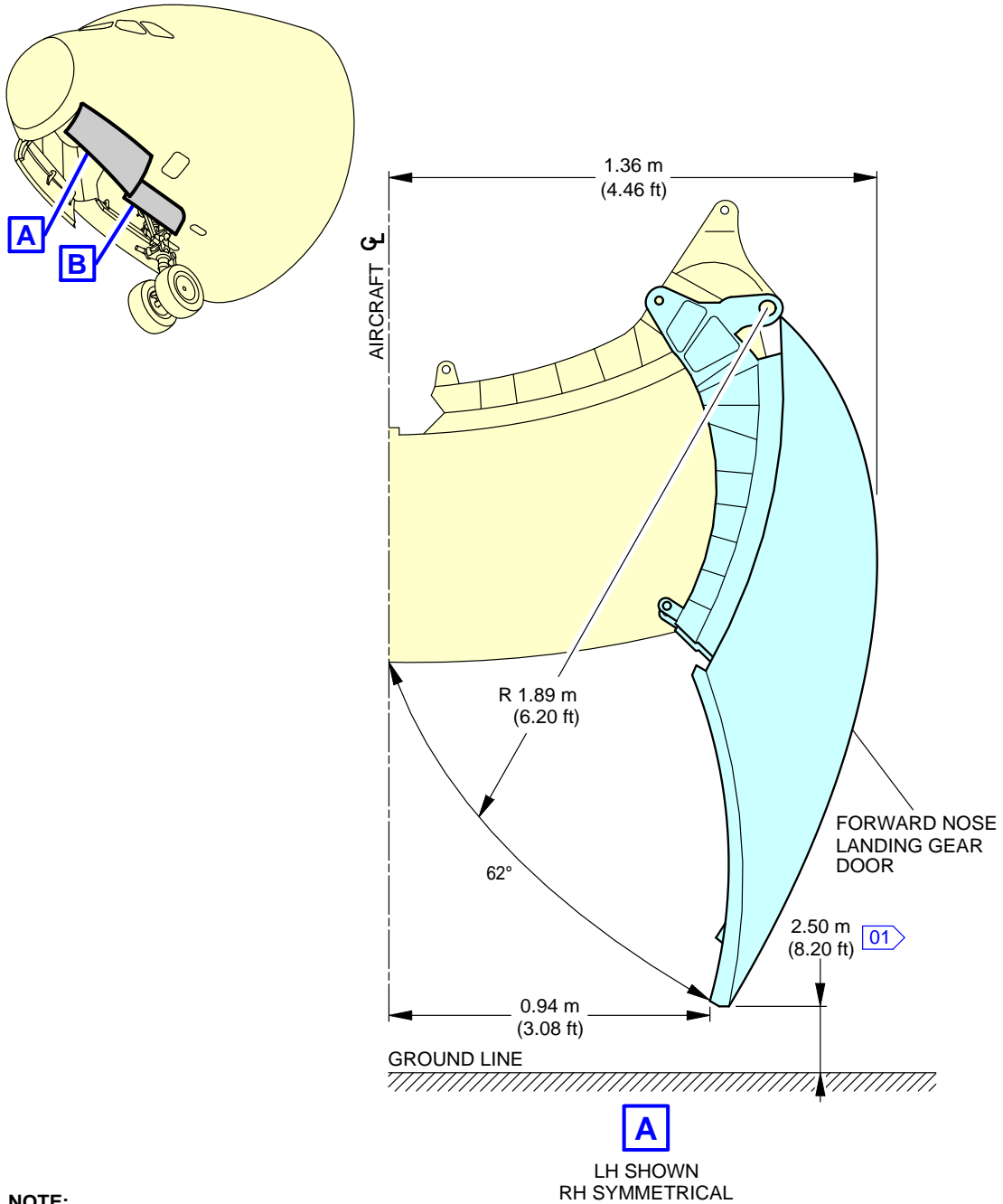

NOTE:

01 DEPENDING ON CG POSITION AND AIRCRAFT WEIGHT.

L_AC_020700_1_0100101_01_01

Door Clearances
 Forward Nose Landing Gear Doors (Sheet 1 of 2)
 FIGURE-2-7-0-991-010-A01

****ON A/C A380-800**

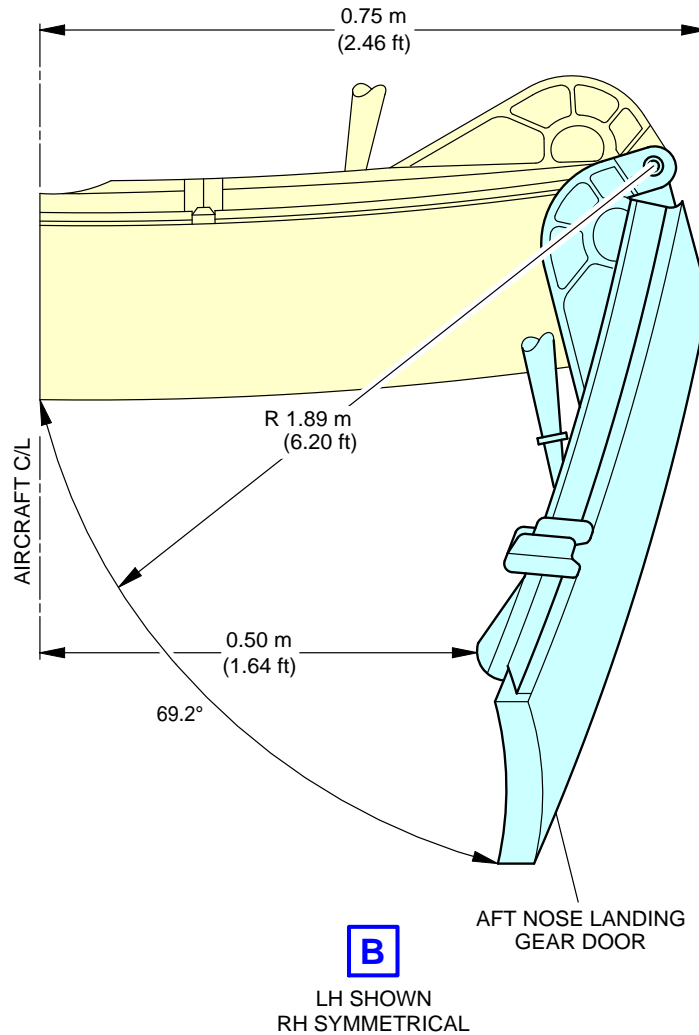

L_AC_020700_1_0100102_01_00

Door Clearances
Aft Nose Landing Gear Doors (Sheet 2 of 2)
FIGURE-2-7-0-991-010-A01

****ON A/C A380-800**

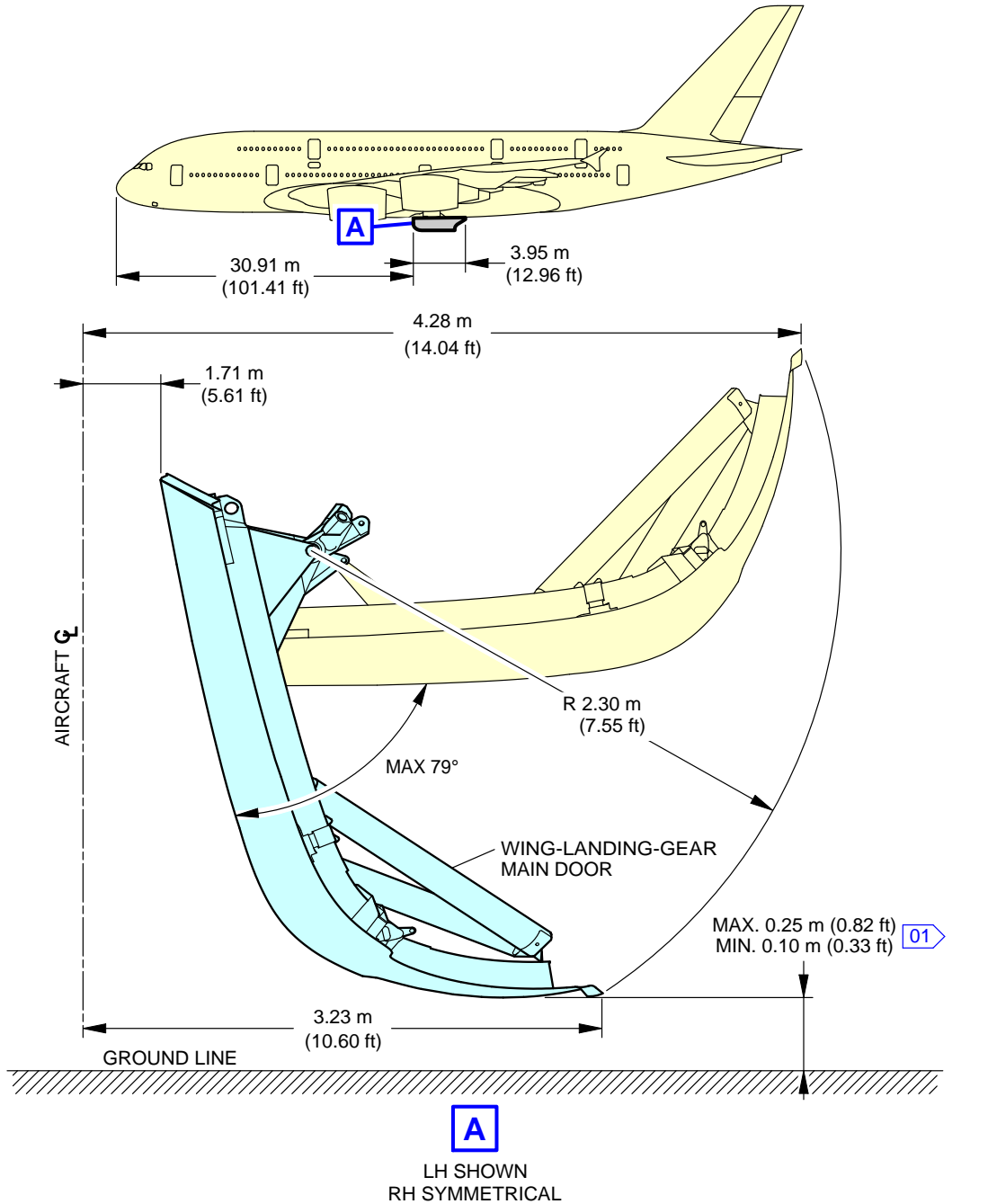

NOTE:

01 DEPENDING ON CG POSITION AND AIRCRAFT WEIGHT.

L_AC_020700_1_0110101_01_00

Door Clearances
Wing Landing Gears - Main Doors
FIGURE-2-7-0-991-011-A01

****ON A/C A380-800**

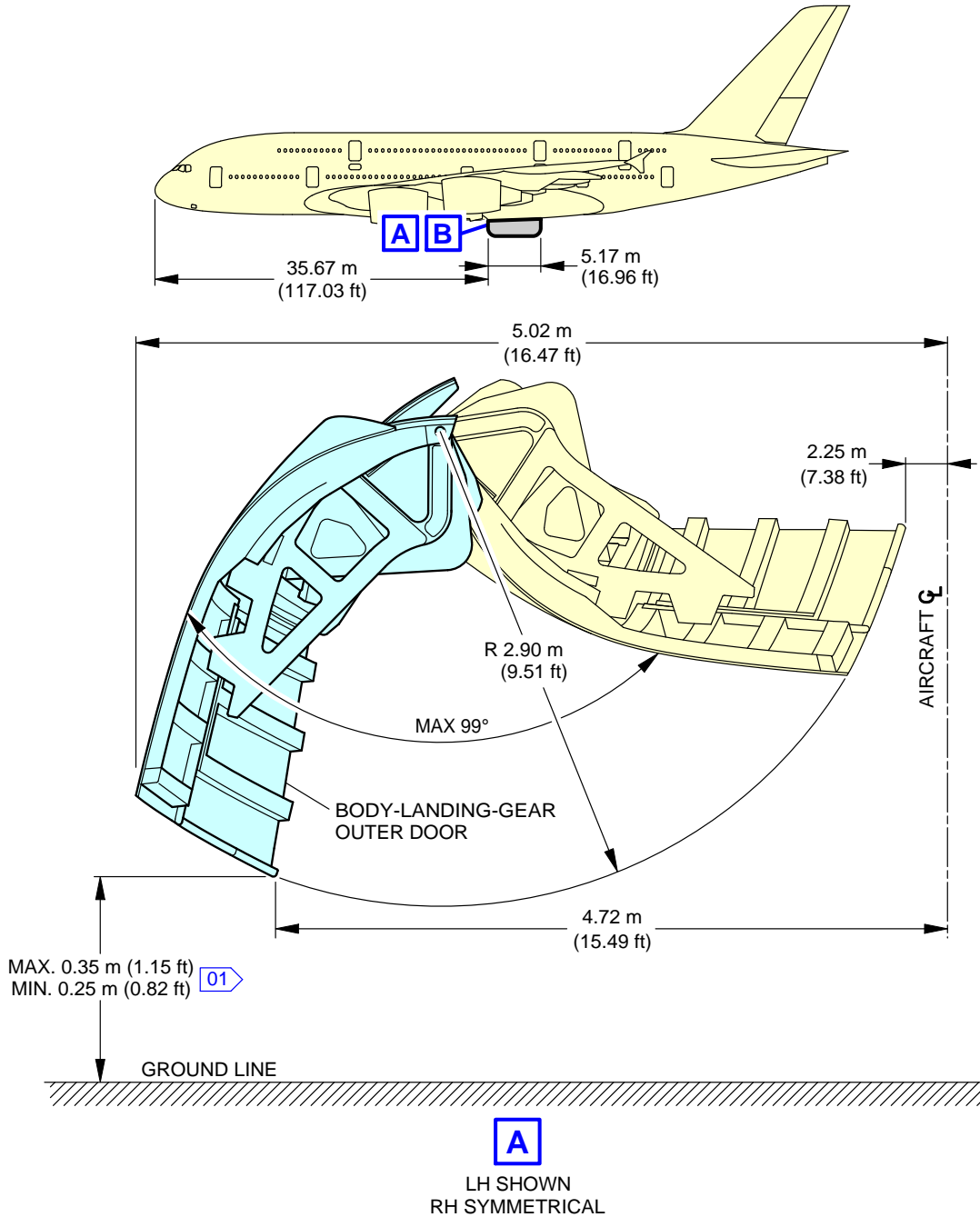

NOTE:

01 DEPENDING ON CG POSITION AND AIRCRAFT WEIGHT.

L_AC_020700_1_0120101_01_00

Door Clearances
Body Landing Gears - Outer Doors (Sheet 1 of 2)
FIGURE-2-7-0-991-012-A01

****ON A/C A380-800**

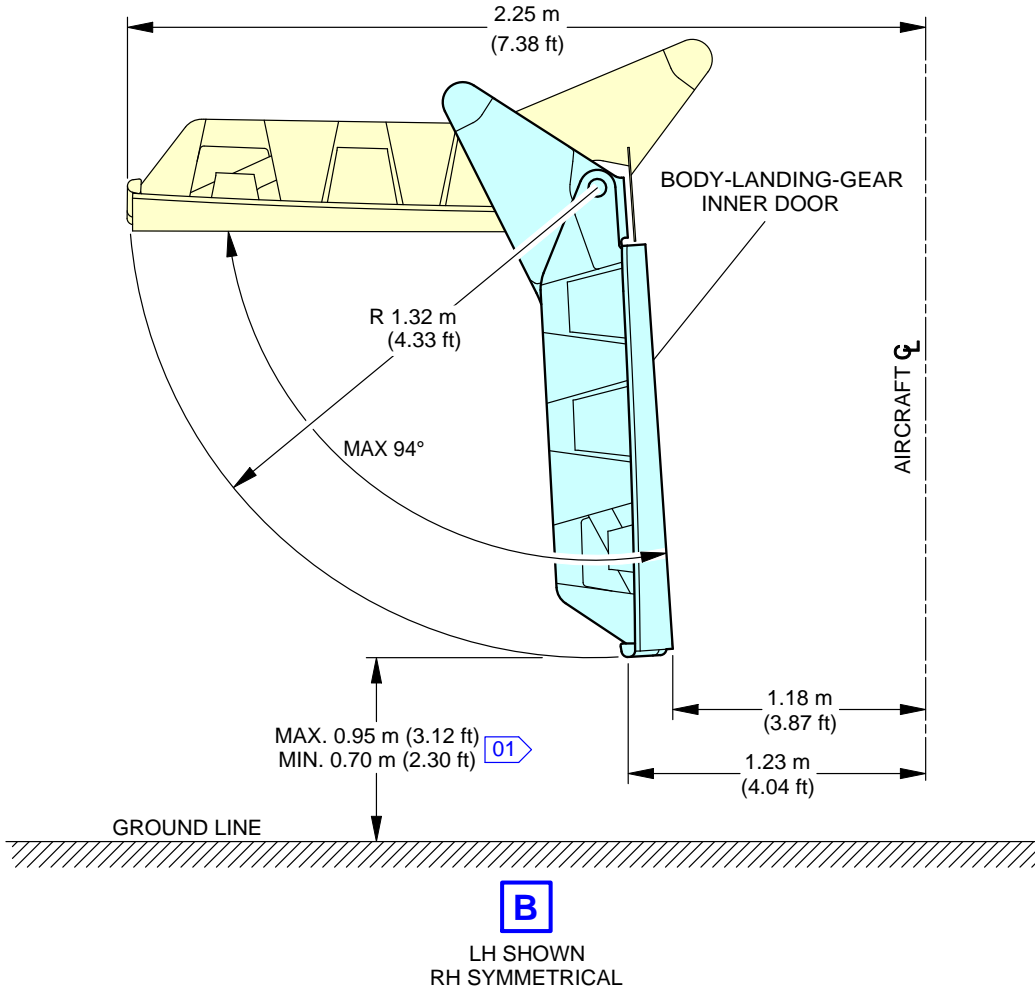

NOTE:

01 DEPENDING ON CG POSITION AND AIRCRAFT WEIGHT.

L_AC_020700_1_0120102_01_00

Door Clearances
 Body Landing Gears - Inner Doors (Sheet 2 of 2)
 FIGURE-2-7-0-991-012-A01

****ON A/C A380-800**

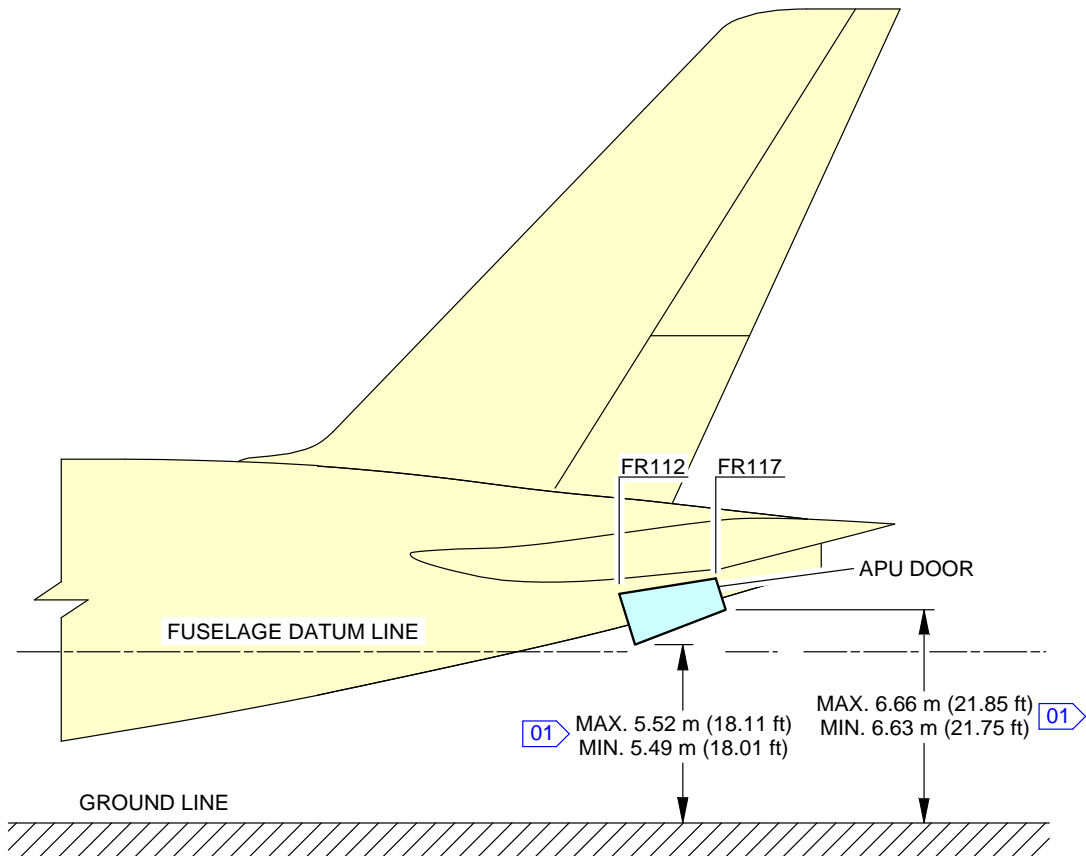

NOTE:

01 DEPENDING ON CG POSITION AND AIRCRAFT WEIGHT.

L_AC_020700_1_0130101_01_00

Door Clearances
APU Doors
FIGURE-2-7-0-991-013-A01

2-8-0 Escape Slides****ON A/C A380-800**Escape Slides

1. General

This section provides the location of cabin escape facilities and related clearances.

2. Location

A. Escape facilities are provided at the following locations:

(1) Upper deck evacuation:

- One slide-raft at each passenger/crew door (total six).

(2) Main deck evacuation:

- One slide-raft at each passenger/crew door (total eight)
- One ramp/slide for each emergency exit door (total two). The slides are housed in the belly fairing for off-the-wing evacuation.

****ON A/C A380-800**

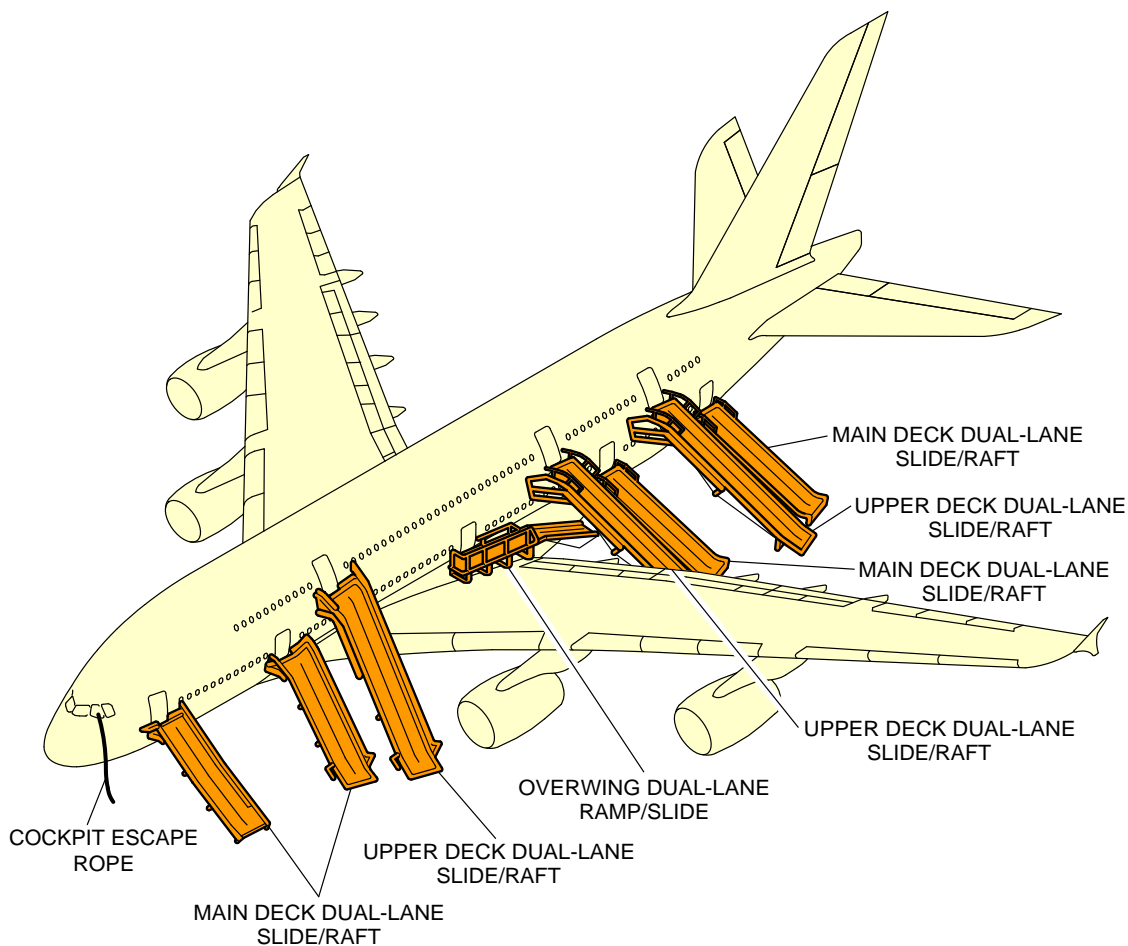

NOTE:

- LH SHOWN, RH SYMMETRICAL.
- THE RAMPS/SLIDES AT DOORS M3L AND M3R DO NOT HAVE RAFT CAPABILITY.

L_AC_020800_1_0010101_01_02

Escape Slides
Location
FIGURE-2-8-0-991-001-A01

****ON A/C A380-800**

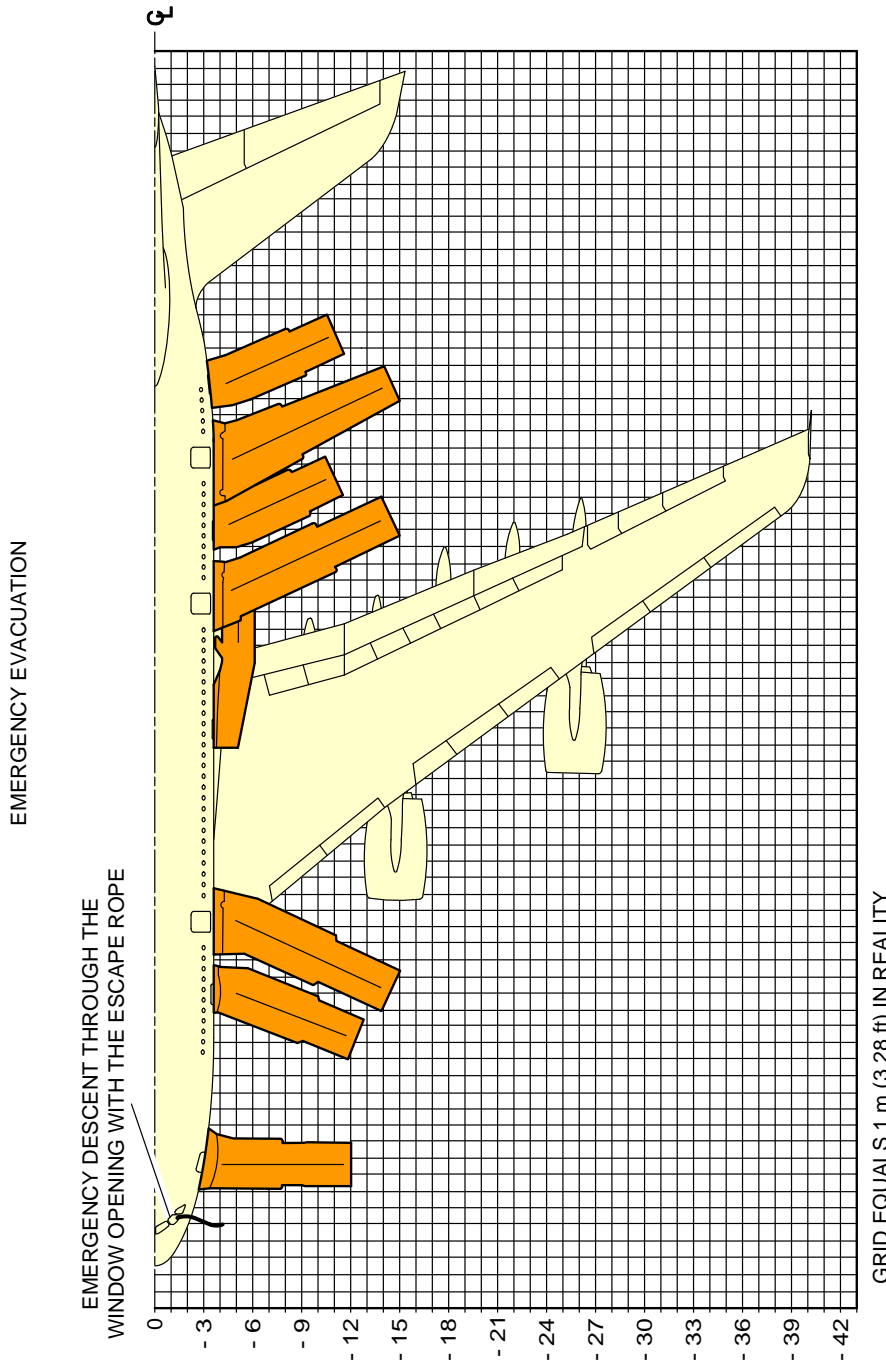

NOTE:
 - LH SHOWN, RH SYMMETRICAL.
 - DIMENSIONS ARE APPROXIMATE.

L_AC_020800_1_0020101_01_02

Escape Slides
 Dimensions
 FIGURE-2-8-0-991-002-A01

2-9-0 Landing Gear

**ON A/C A380-800

Landing Gear

1. General

The aircraft has:

- Two Wing Landing Gears (WLG) with four wheel bogie assembly and related doors,
- Two Body Landing Gears (BLG) with six wheel bogie assembly and related doors,
- A Nose Landing Gear (NLG) with twin wheel assembly and related doors.

The wing landing gears are located under the wing and retract sideways towards the fuselage centerline.

The body landing gears are located on the belly and retract rearward into a bay in the fuselage. The nose landing gear retracts forward into a fuselage compartment below the cockpit.

The landing gear and landing gear doors operation are controlled electrically and are hydraulically and mechanically operated.

In abnormal operation, the landing gear can be extended by gravity.

For landing gear footprint and tire size, refer to 07-02-00.

2. Wing Landing Gear

Each WLG has a leg assembly and a four-wheel bogie beam. The WLG leg includes a Bogie Trim Actuator (BTA) and an oleo-pneumatic shock absorber.

A two-piece sidestay assembly holds the WLG in the extended position. A lockstay keeps the sidestay assembly stable in the locked down position.

3. Body Landing Gear

The two BLG have a six-wheel bogie beam and a leg assembly that includes an oleo-pneumatic shock absorber. A two-piece dragstay assembly mechanically locks the leg in the extended position.

4. Nose Landing Gear

The NLG includes a single-stage direct acting oleo-pneumatic shock absorber. A two-piece dragstay assembly with a lockstay, mechanically locks the leg in the extended position.

5. Tow Truck Power

Electric power to the navigation lights can be provided through the tow truck power connector on the 24GC service panel, see FIGURE 2-9-0-991-007-A and for connector definition, see 05-04-04.

6. Steering

The wheel steering control system has two parts:

- Nose wheel Steering (NWS),
- Body Wheel Steering (BWS).

Steering is controlled by two hand wheels in the cockpit. For steering angle controlled by the hand wheels, refer to AMM 32-51-00 (NWS) and AMM 32-54-00 (BWS).

For steering angle limitation, refer to AMM 09-10-00.

A steering disconnection box installed on the nose landing gear to allow steering deactivation for towing purpose.

7. Landing Gear Servicing Points

A. General

Filling of the landing gear shock absorbers is through MS28889 standard valves.

Charging of the landing gear shock absorbers is accomplished with nitrogen through MS28889 standard valves.

B. Charging Pressure

For charging of the landing gear shock absorbers, refer to AMM 32-00-00.

8. Braking

A. General

Carbon brakes are installed on each wheel of the WLG and on the wheels of the front and center axles of the BLG.

The braking system is electrically controlled and hydraulically operated.

The braking system has four braking modes plus autobrake and anti-skid systems:

- Normal braking with anti-skid capability,
- Alternative braking with anti-skid capability,
- Emergency Braking (with Ultimate Braking),
- Emergency braking without anti-skid protection is also available as an alternative function of the alternate braking system,

- A park brake system that is manually set is available for the BLG only. This system can also be used to supply emergency braking.

B. In-Flight Wheel Braking

Braking occurs automatically during the retraction of the landing gear. This stops the rotation of the BLG and WLG wheels (except the wheels on the aft axle of each BLG) before the landing gears go into their related bays.

9. Tire Pressure Indicating System (TPIS)

The TPIS automatically monitors the tire pressures and shows these values on Built In Test Equipment (BITE) and also supplies other data and warnings on the WHEEL page of the System Display (SD).

The TPIS includes Built In Test Equipment.

10. Built In Test Equipment (BITE)

The BITE has these functions, it:

- Continuously monitors its systems for failures,
- Sends failure data (maintenance and warnings) to other systems in the aircraft,
- Keeps a record of the failures,
- Automatically does specified tests of the system, or part of the system, at specified times,
- Lets specified tests to be done during the maintenance procedures.

The BITE for the following systems is described in these chapters:

- The Brakes AMM 32-46-00,
- The Steering AMM 32-52-00,
- The TPIS AMM 32-49-00,
- The Landing Gear AMM 32-69-00.

****ON A/C A380-800**

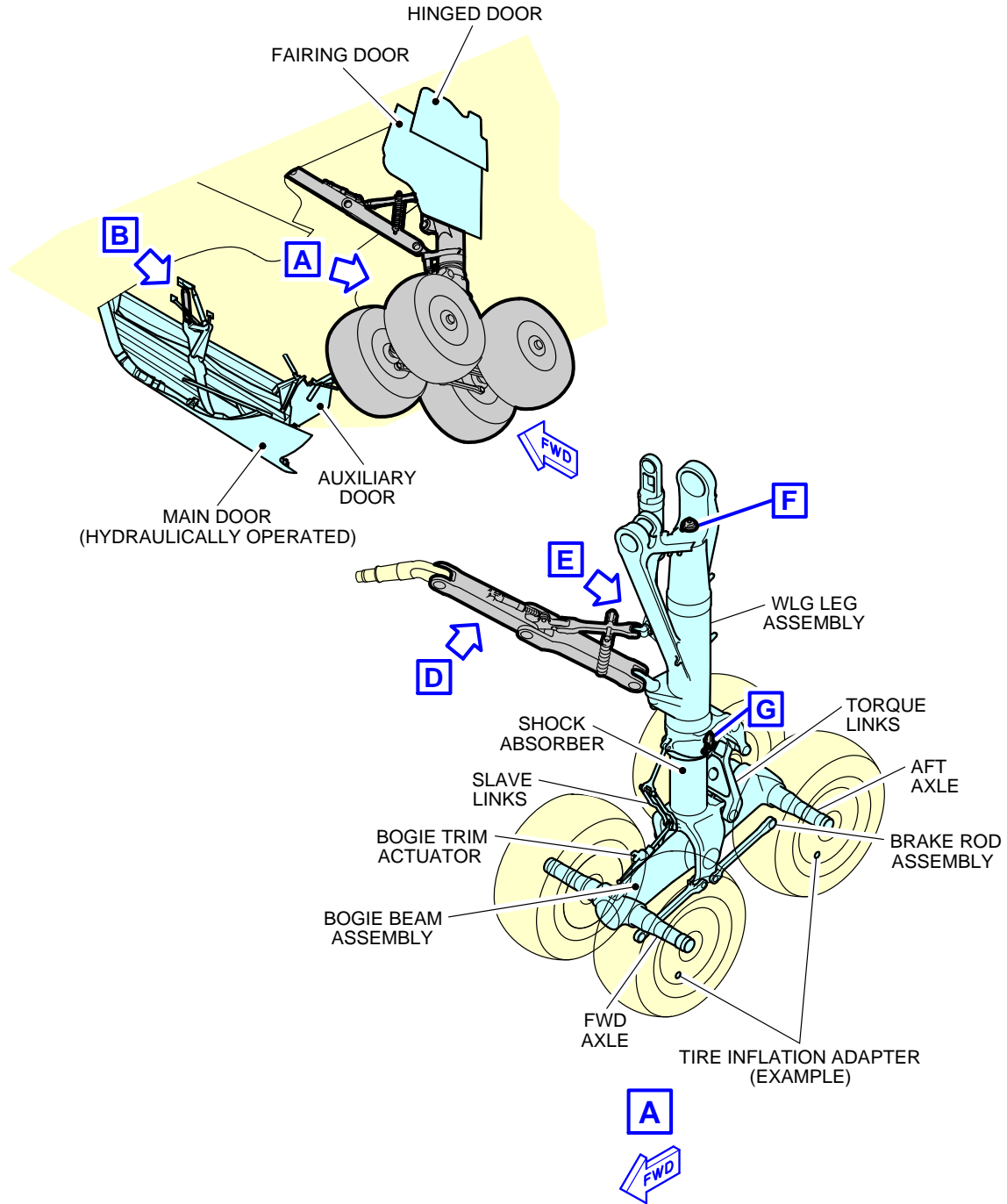

L_AC_020900_1_0050101_01_00

Wing Landing Gear
General (Sheet 1 of 3)
FIGURE-2-9-0-991-005-A01

****ON A/C A380-800**

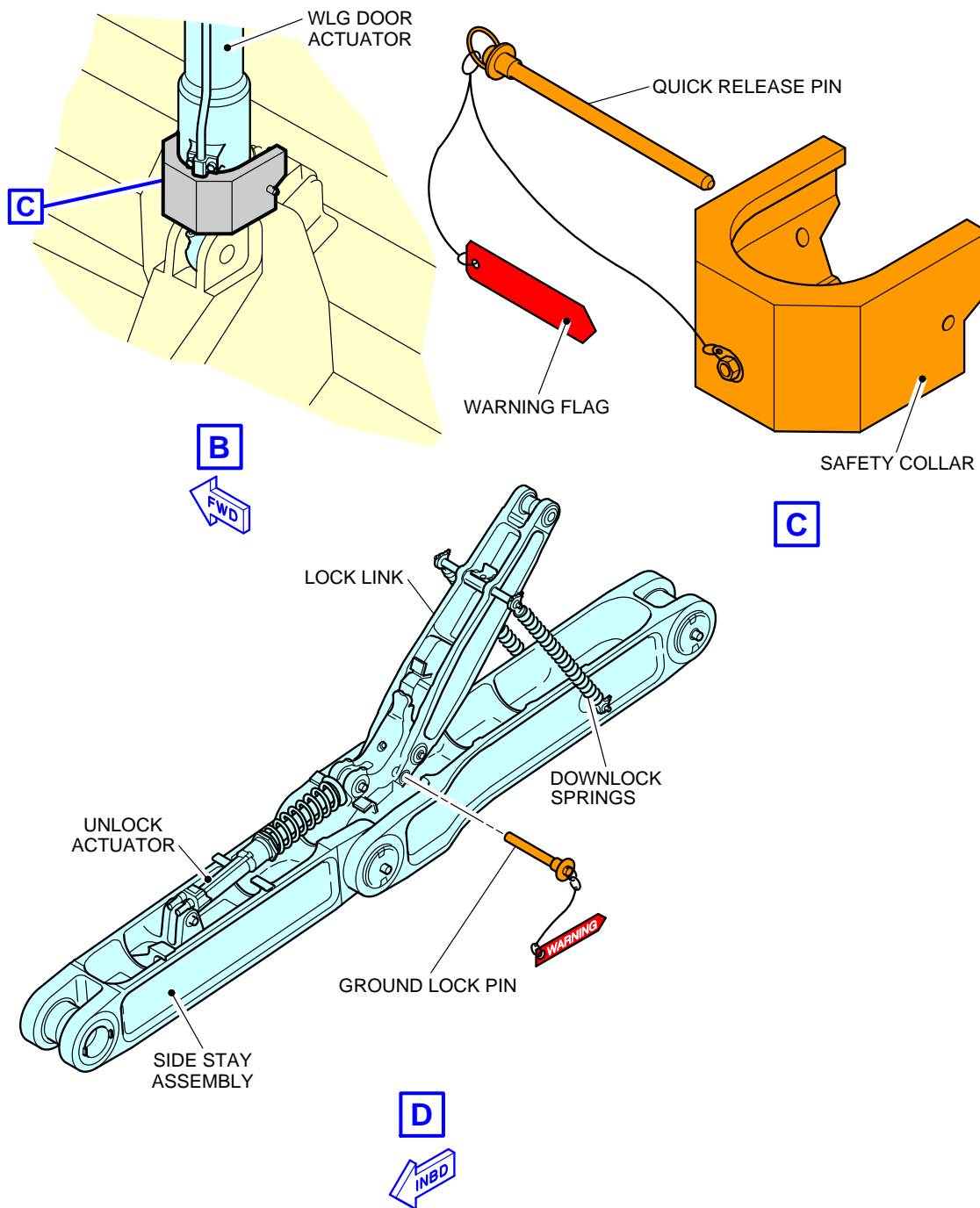

L_AC_020900_1_0050102_01_00

Wing Landing Gear
Safety Devices (Sheet 2 of 3)
FIGURE-2-9-0-991-005-A01

****ON A/C A380-800**

GROUNDING (EARTHING) POINT

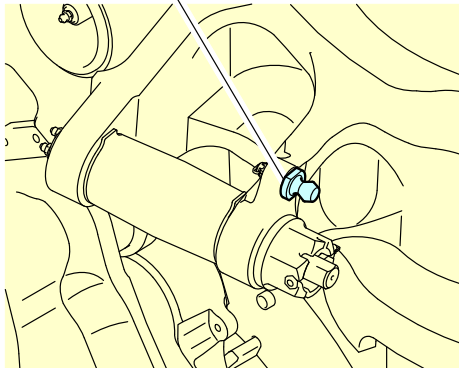

E



CHARGE VALVE (NITROGEN)

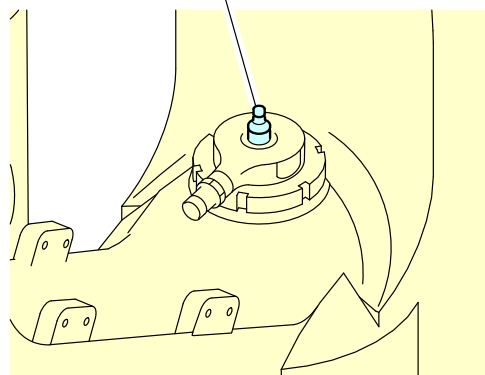

F

CHECK/FILL VALVE (OIL)

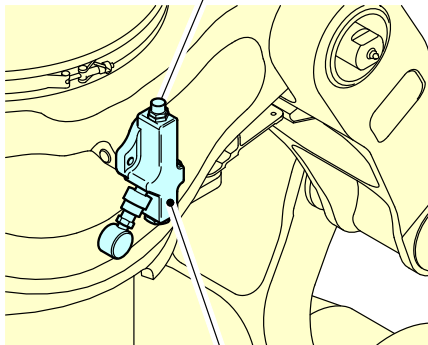

SEAL CHANGEOVER VALVE (COV)

G

L_AC_020900_1_0050103_01_01

Wing Landing Gear
Servicing (Sheet 3 of 3)
FIGURE-2-9-0-991-005-A01

****ON A/C A380-800**

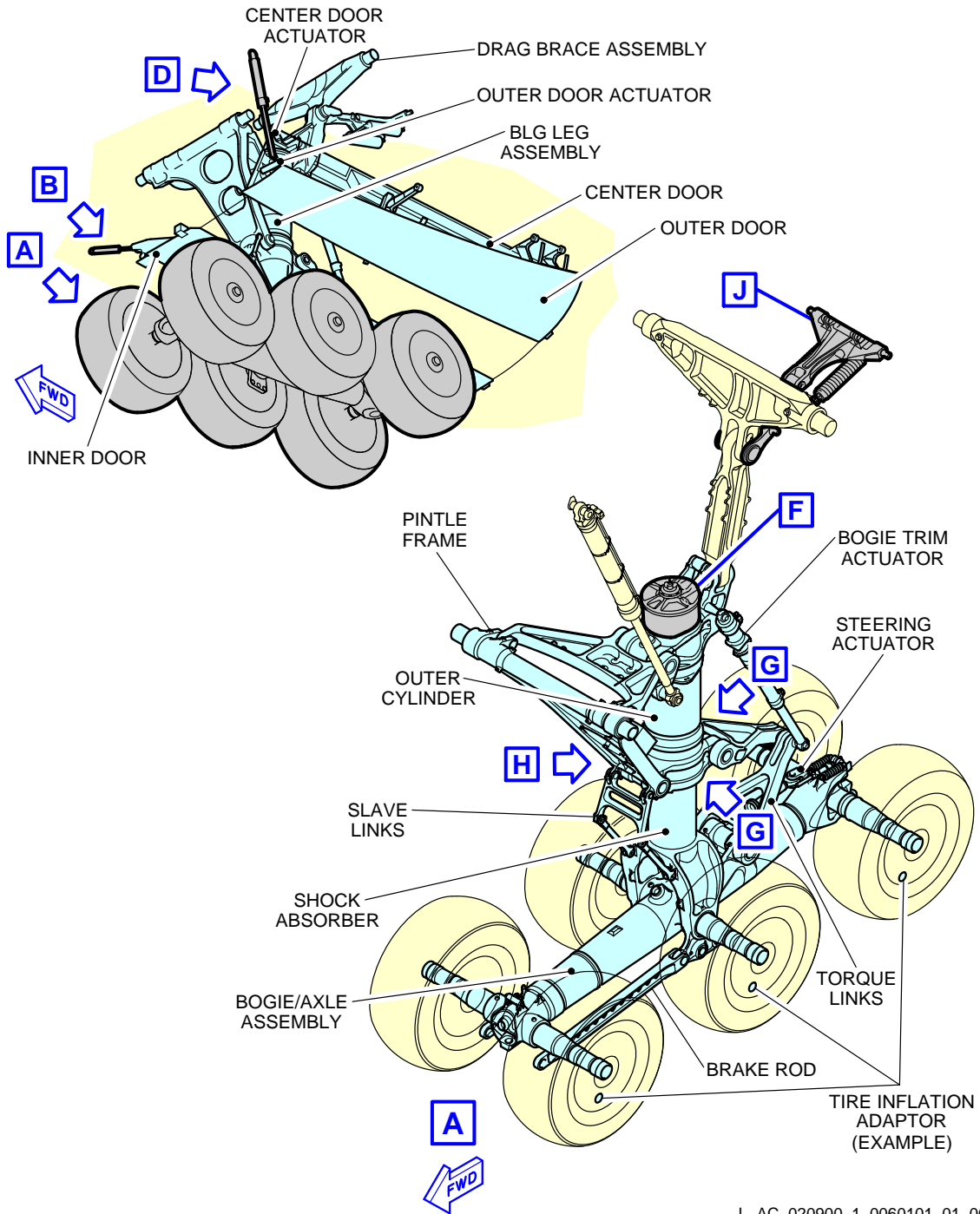

L_AC_020900_1_0060101_01_00

Body Landing Gear
General (Sheet 1 of 4)
FIGURE-2-9-0-991-006-A01

****ON A/C A380-800**

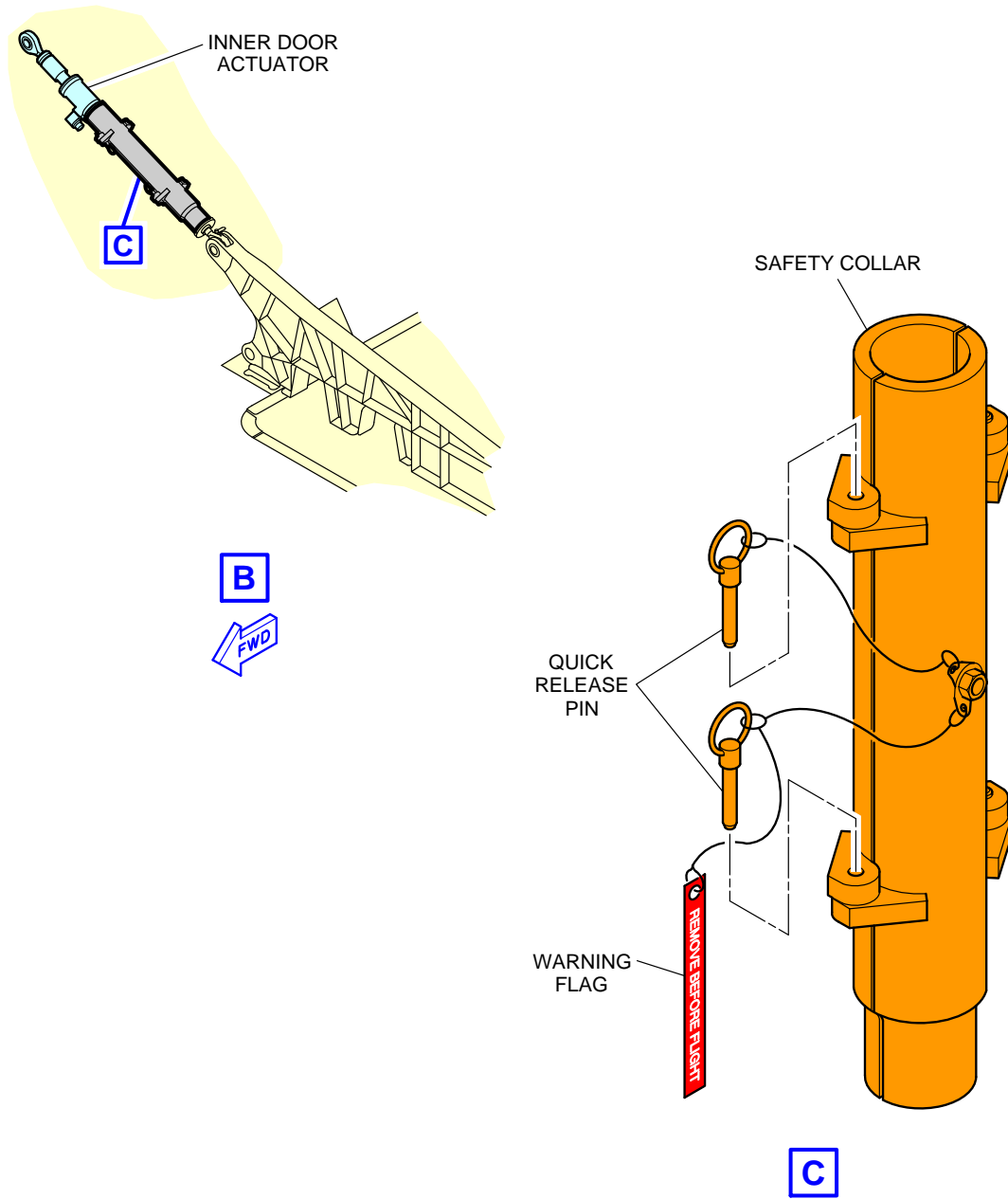

L_AC_020900_1_0060102_01_01

Body Landing Gear
Door Safety Devices (Sheet 2 of 4)
FIGURE-2-9-0-991-006-A01

****ON A/C A380-800**

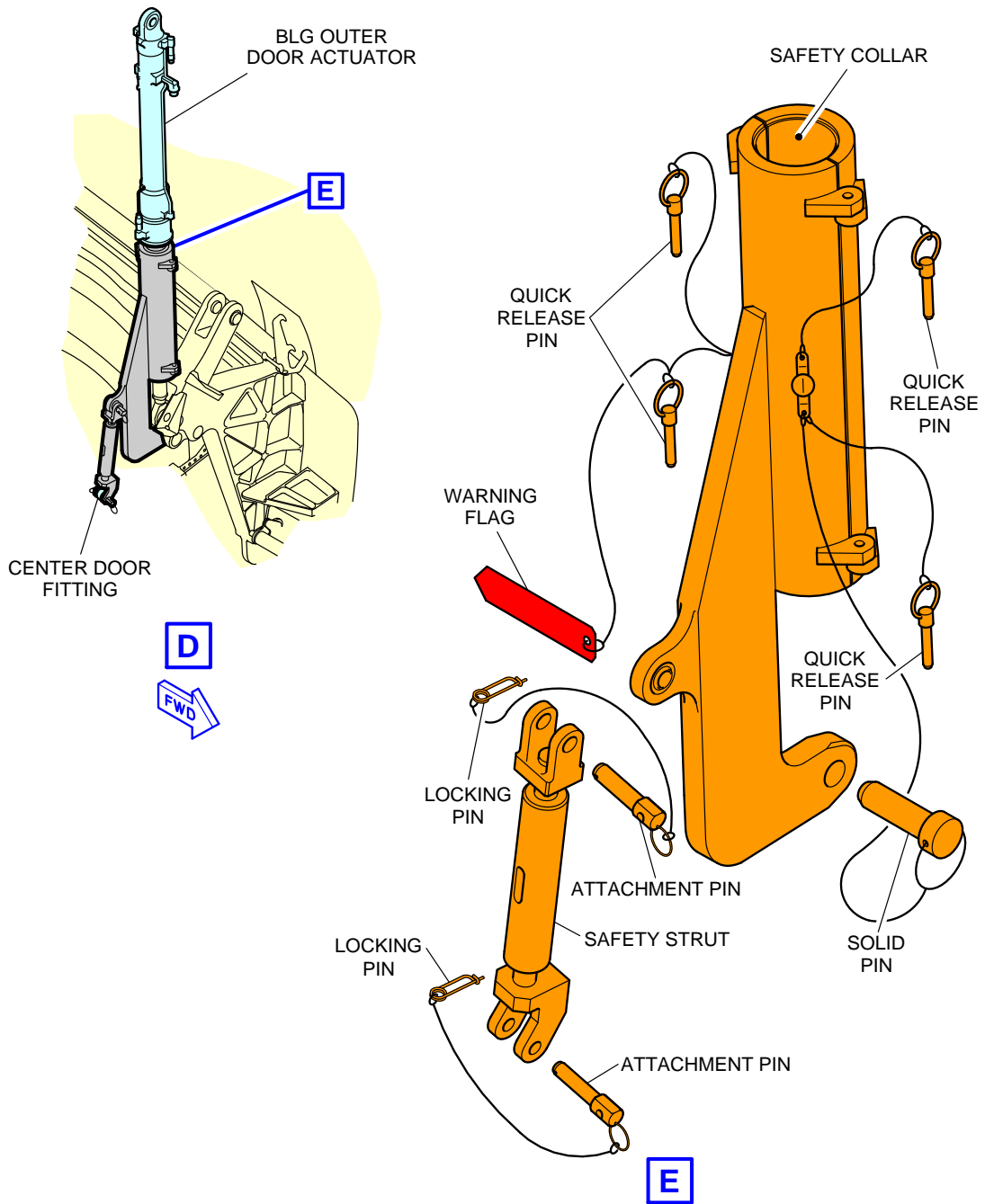

L_AC_020900_1_0060103_01_00

Body Landing Gear
Door Safety Devices (Sheet 3 of 4)
FIGURE-2-9-0-991-006-A01

****ON A/C A380-800**

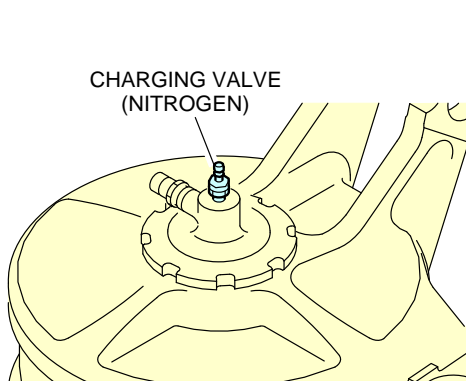

F

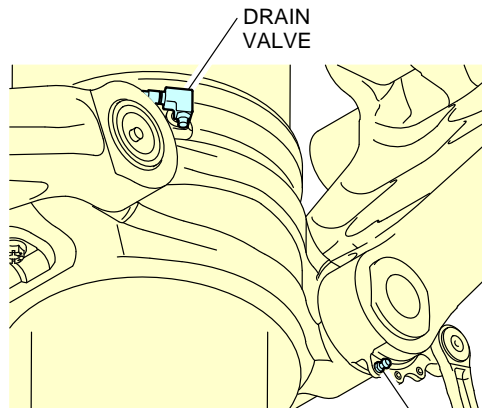

G

TYPICAL

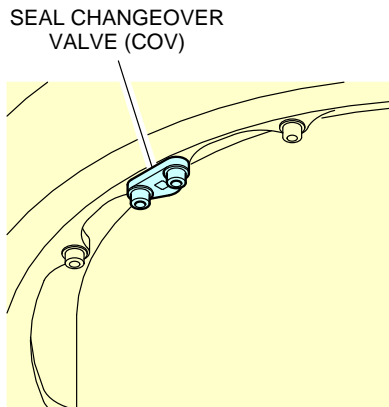

H

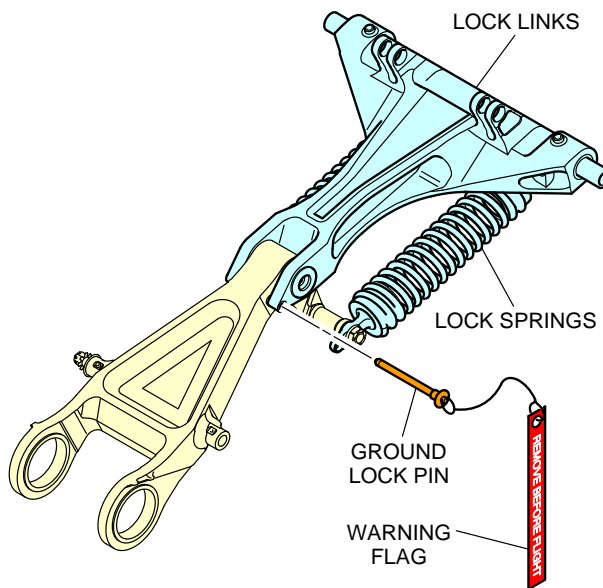

J

L_AC_020900_1_0060104_01_01

Body Landing Gear
Servicing and Safety Device (Sheet 4 of 4)
FIGURE-2-9-0-991-006-A01

****ON A/C A380-800**

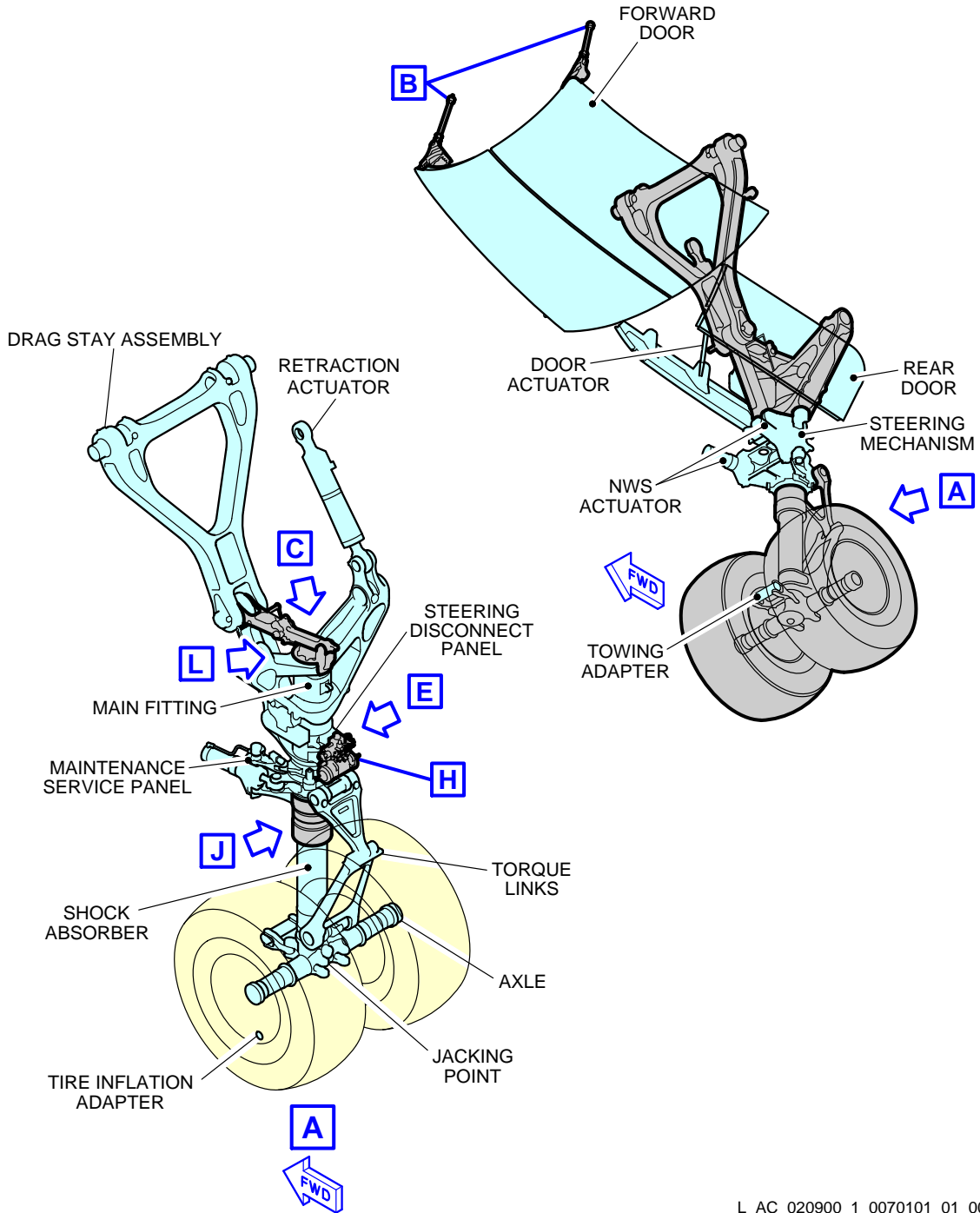

L_AC_020900_1_0070101_01_00

Nose Landing Gear
General (Sheet 1 of 4)
FIGURE-2-9-0-991-007-A01

****ON A/C A380-800**

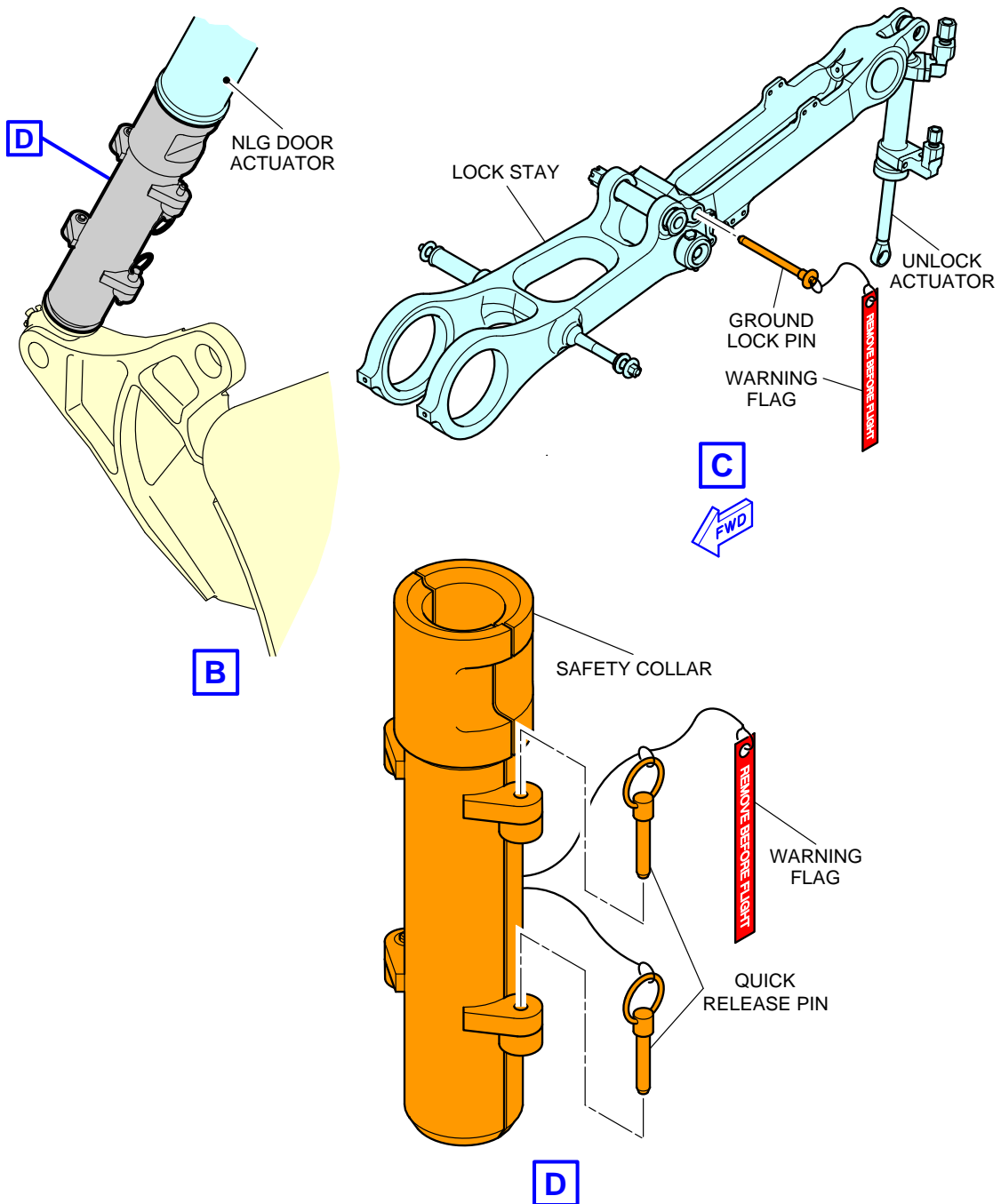

L_AC_020900_1_0070102_01_01

Nose Landing Gear
Safety Devices (Sheet 2 of 4)
FIGURE-2-9-0-991-007-A01

****ON A/C A380-800**

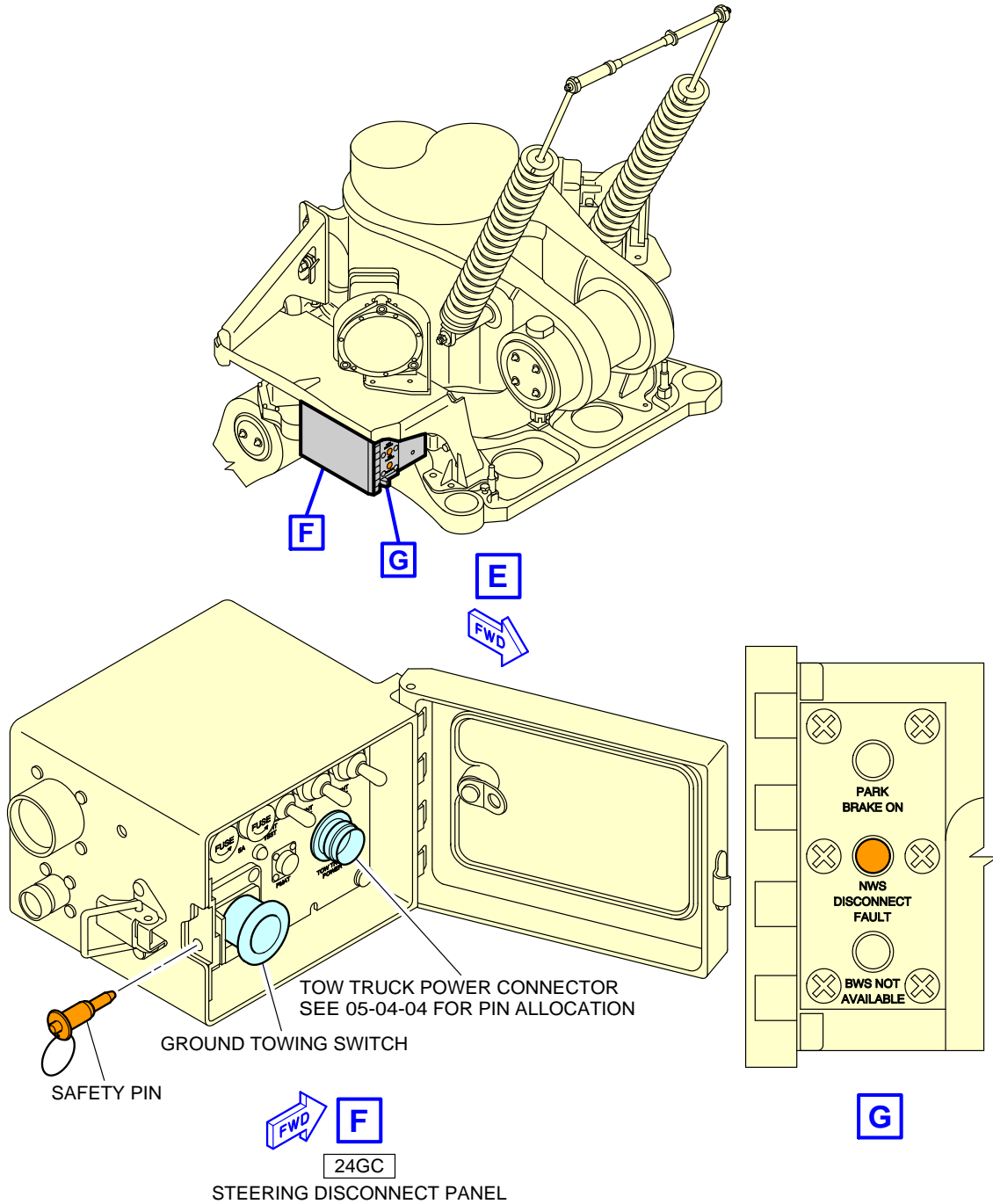

L_AC_020900_1_0070103_01_01

Nose Landing Gear
Steering Disconnect Panel (Sheet 3 of 4)
FIGURE-2-9-0-991-007-A01

****ON A/C A380-800**

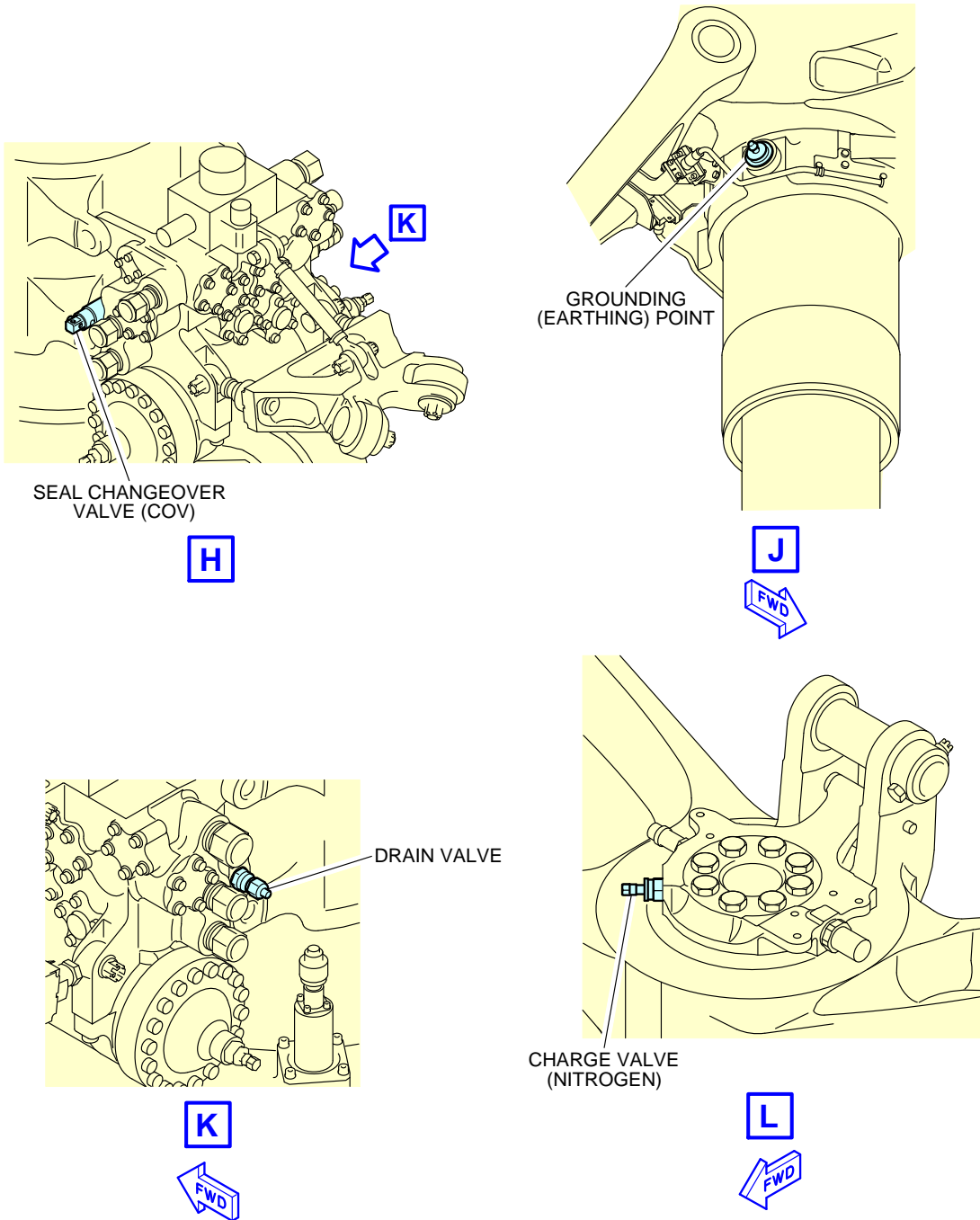

L_AC_020900_1_0070104_01_01

Nose Landing Gear
Servicing (Sheet 4 of 4)
FIGURE-2-9-0-991-007-A01

****ON A/C A380-800**Landing Gear Maintenance Pits

1. General

The minimum maintenance pit envelopes for the landing gear shock absorber maintenance are shown in FIGURE 2-9-0-991-001-A, FIGURE 2-9-0-991-002-A, FIGURE 2-9-0-991-003-A and FIGURE 2-9-0-991-004-A.

The three envelopes show the minimum dimensions for these maintenance operations:

- Extension and retraction
- Gear removal
- Piston removal.

All dimensions shown are minimum dimensions with zero clearances. The dimensions for the pits have been determined as follows:

- The length and width of the pits allow the gear to rotate as the weight is taken off the landing gear
- The landing gear is in the maximum grown condition
- The WLG and BLG bogie beams are removed before the piston is removed
- The NLG wheels are removed before the piston is removed
- All pistons are removed vertically.

Dimensions for elevators and associated mechanisms must be added to those in FIGURE 2-9-0-991-001-A, FIGURE 2-9-0-991-002-A, FIGURE 2-9-0-991-003-A and FIGURE 2-9-0-991-004-A.

A. Elevators

These can be either mechanical or hydraulic. They are used to:

- Permit easy movement of persons and equipment around the landing gears
- Lift and remove landing gear assemblies out of the pits.

B. Jacking

The aircraft must be in position over the pits to put the gear on the elevators. Jacks must be installed and engaged with all the jacking points, Ref. 02-14-00 for aircraft maintenance jacking. Jacks must support the total aircraft weight, i.e. when the landing gears do not touch the elevators on retraction/extension tests.

When tripod support jacks are used the tripod-base circle radius must be limited because the locations required for positioning the columns are close to the sides of the pits.

****ON A/C A380-800**

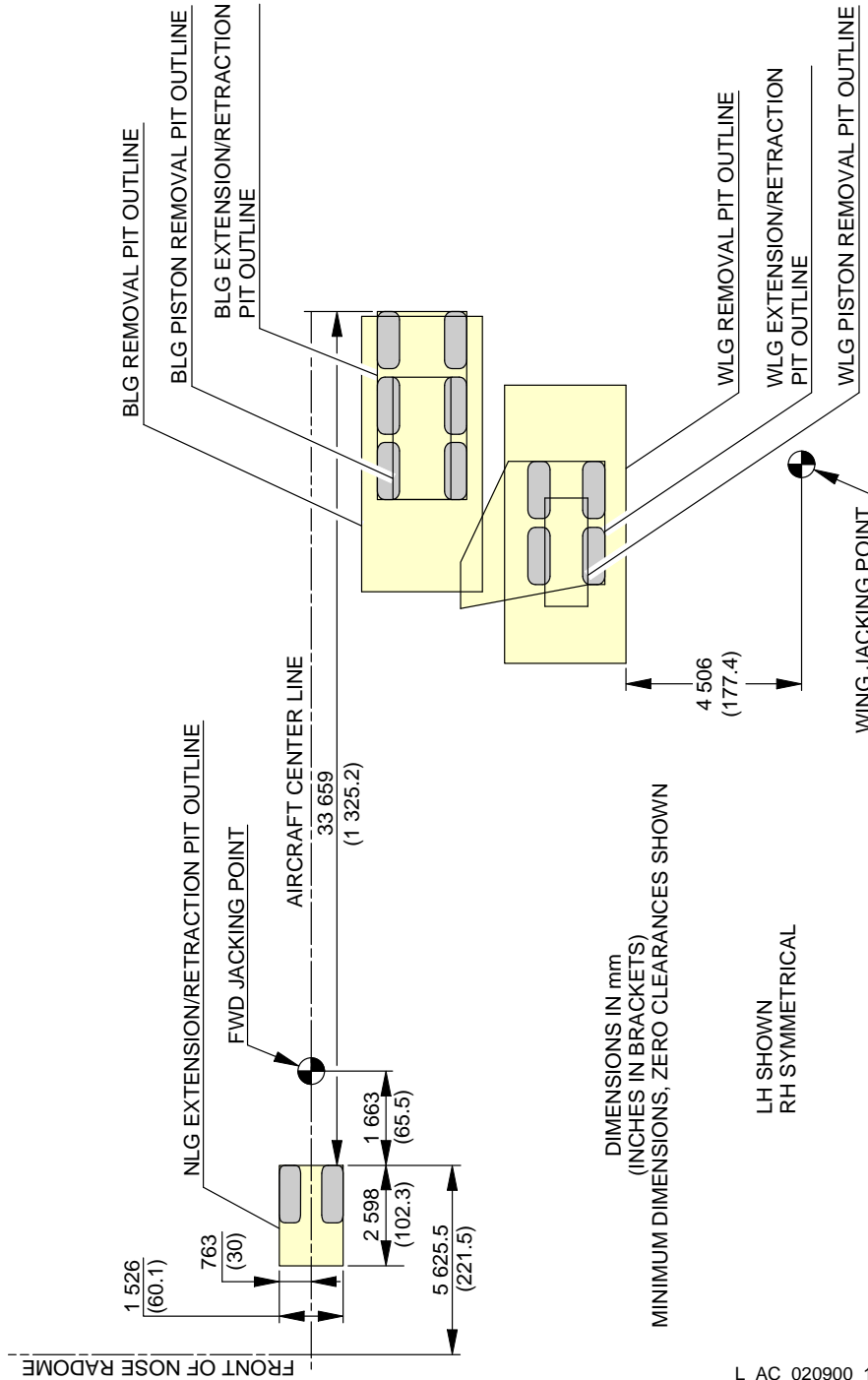

L_AC_020900_1_0010101_01_00

Landing Gear Maintenance Pits
 Maintenance Pit Envelopes
 FIGURE-2-9-0-991-001-A01

****ON A/C A380-800**

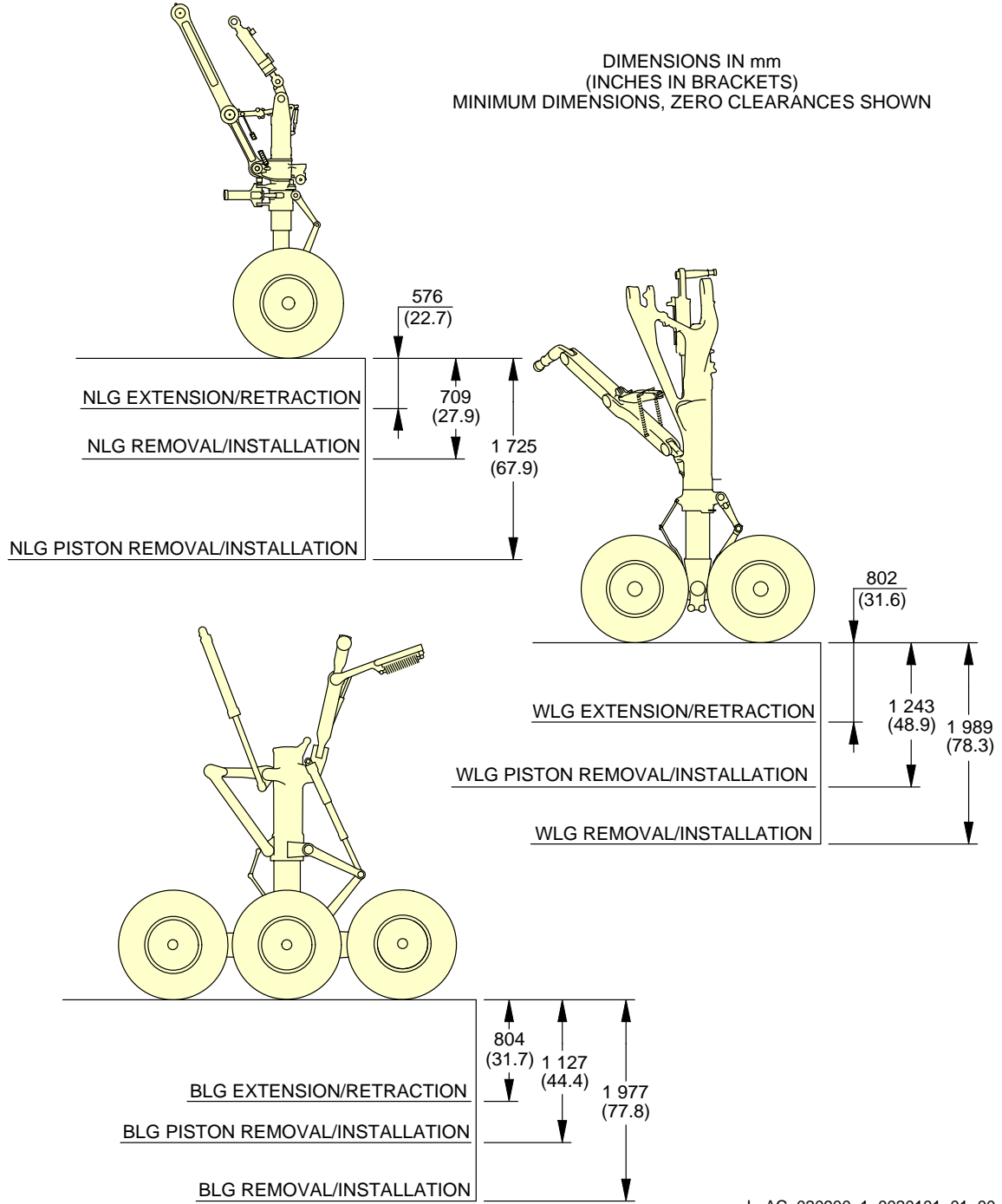

L_AC_020900_1_0020101_01_00

Landing Gear Maintenance Pits
Necessary Depths
FIGURE-2-9-0-991-002-A01

****ON A/C A380-800**

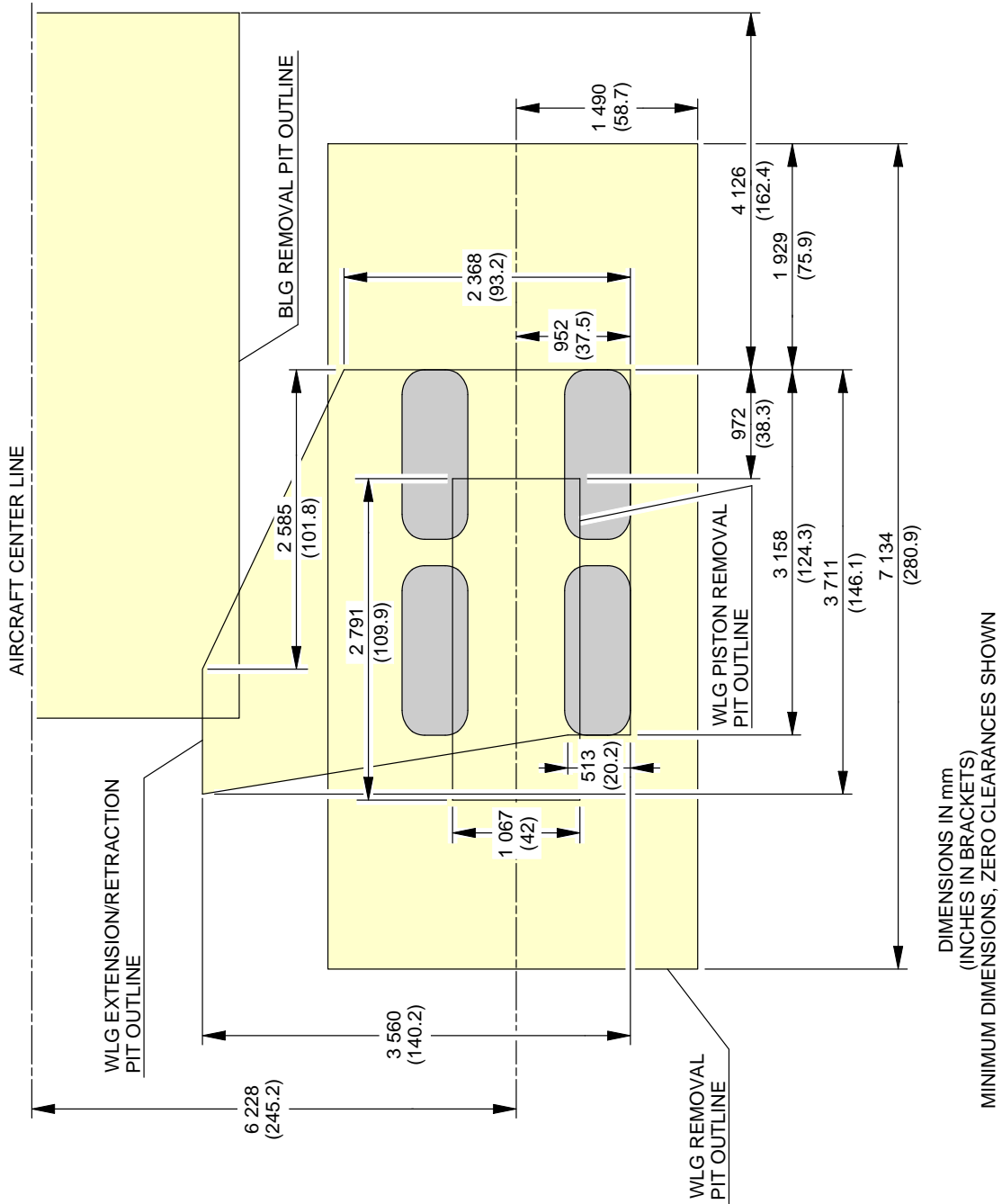

L_AC_020900_1_0030101_01_00

Landing Gear Maintenance Pits
Maintenance Pit Envelopes - WLG Pit Dimensions
FIGURE-2-9-0-991-003-A01

****ON A/C A380-800**

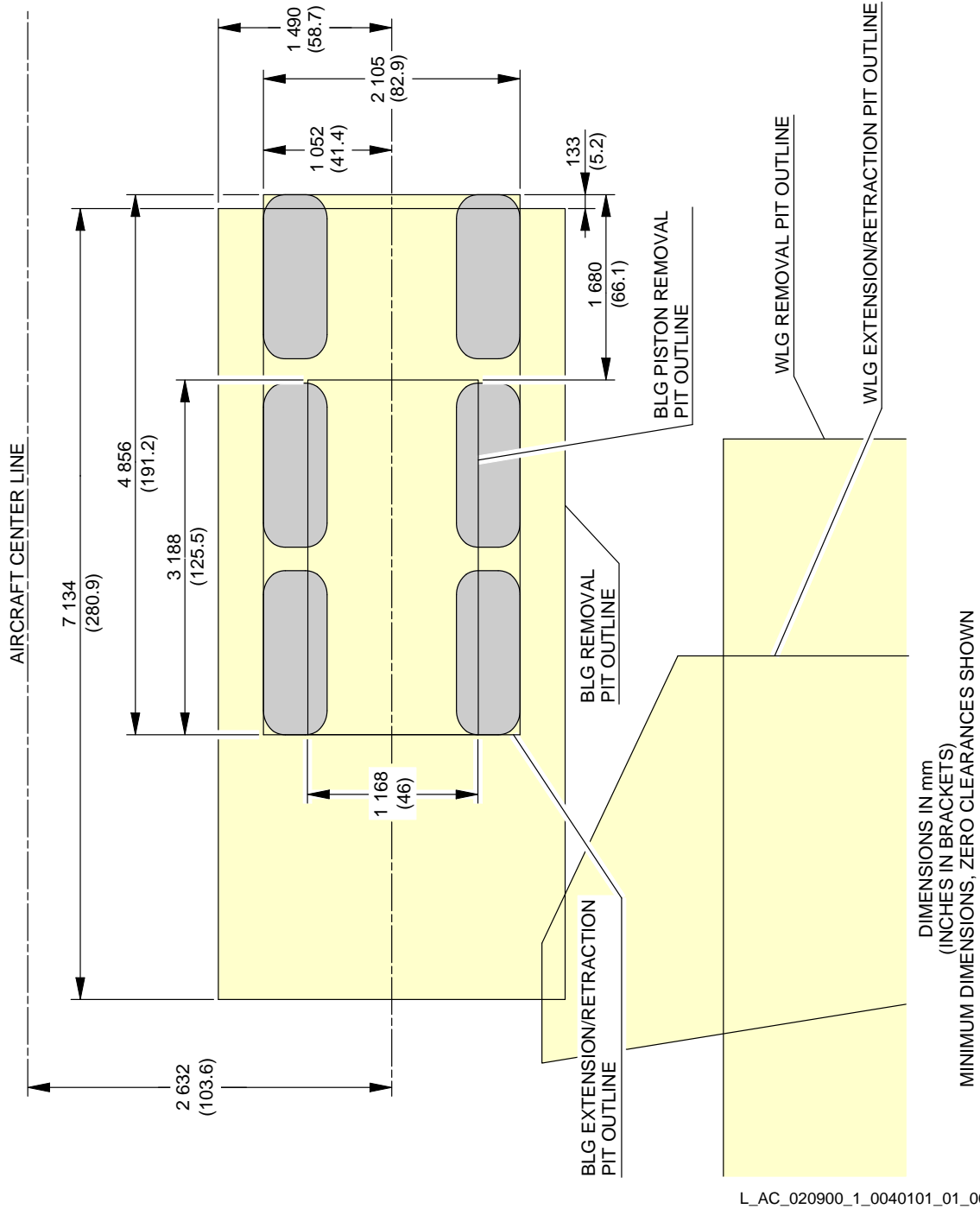

Landing Gear Maintenance Pits
Maintenance Pit Envelopes - BLG Pit Dimensions
FIGURE-2-9-0-991-004-A01

2-10-0 Exterior Lighting****ON A/C A380-800**Exterior Lighting

1. General

This section gives the location of the aircraft exterior lighting.

EXTERIOR LIGHTING	
ITEM	DESCRIPTION
1	RIGHT NAVIGATION LIGHT (GREEN)
2	LEFT NAVIGATION LIGHT (RED)
3	TAIL NAVIGATION LIGHT (WHITE)
4	OBSTRUCTION LIGHT
5	UPPER ANTI-COLLISION LIGHTS/BEACONS (RED)
6	LOWER ANTI-COLLISION LIGHT/BEACON (RED)
7	LOGO LIGHTS
8	ENGINE SCAN LIGHTS
9	WING SCAN LIGHTS
10	WING STROBE LIGHT (HIGH INTENSITY, WHITE)
11	TAIL STROBE LIGHT (HIGH INTENSITY, WHITE)
12	TAXI CAMERA LIGHTS (NLG)
13	TAXI CAMERA LIGHTS (MLG)
14	LANDING LIGHTS
15	RUNWAY TURN-OFF LIGHTS
16	TAXI LIGHTS
17	TAKE-OFF LIGHTS
18	CARGO COMPARTMENT FLOOD LIGHTS
19	LANDING GEAR BAY/WELL LIGHTS (DOME)

****ON A/C A380-800**

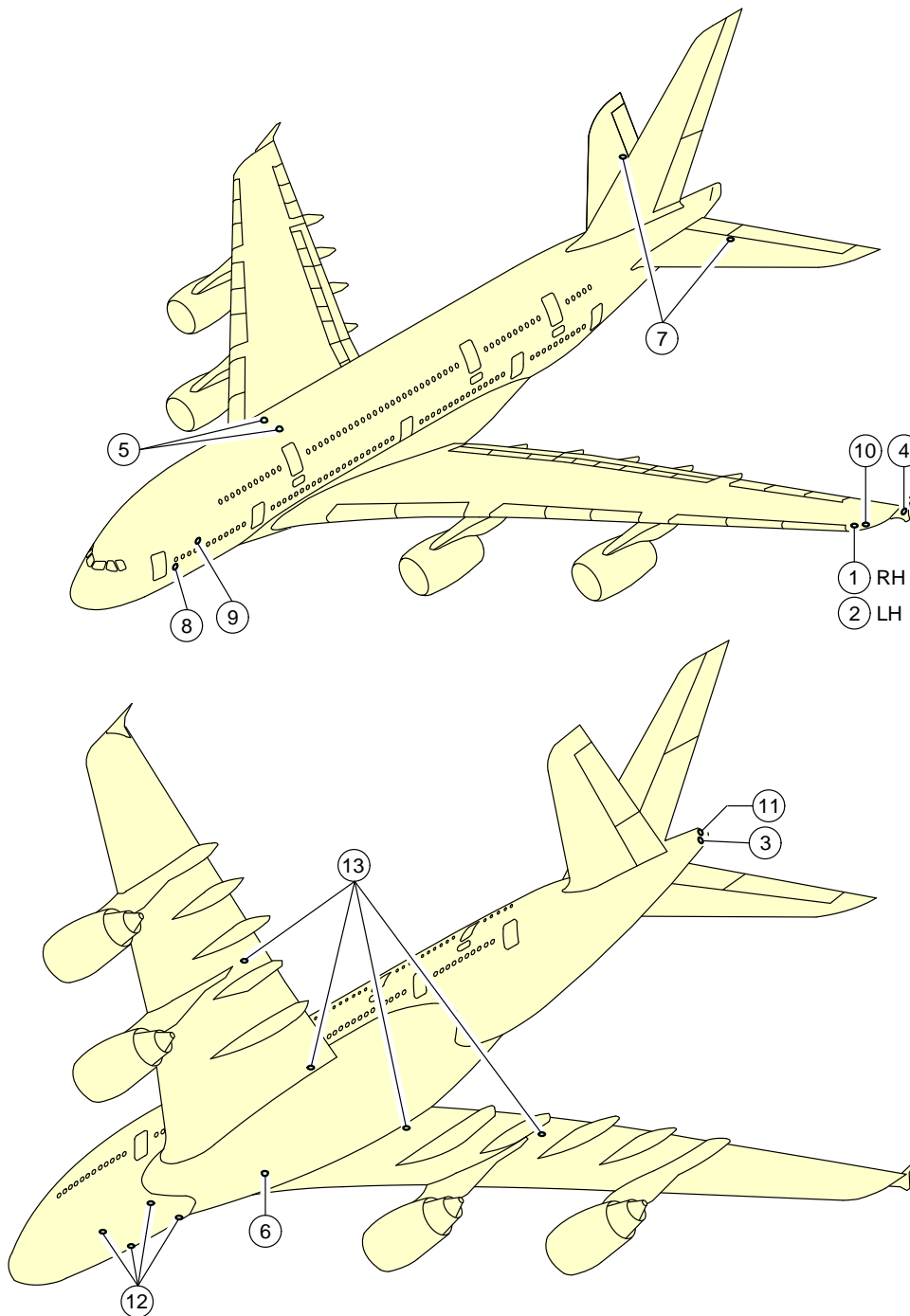

L_AC_021000_1_0070101_01_00

Exterior Lighting
FIGURE-2-10-0-991-007-A01

****ON A/C A380-800**

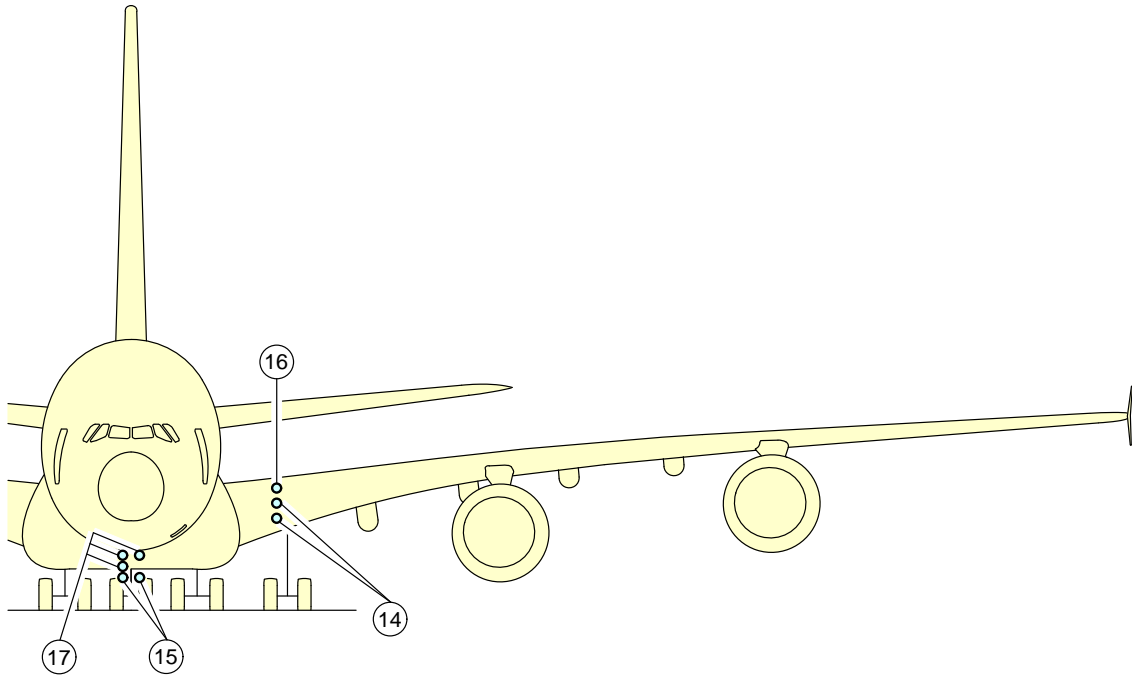

L_AC_021000_1_0080101_01_00

Exterior Lighting
FIGURE-2-10-0-991-008-A01

****ON A/C A380-800**

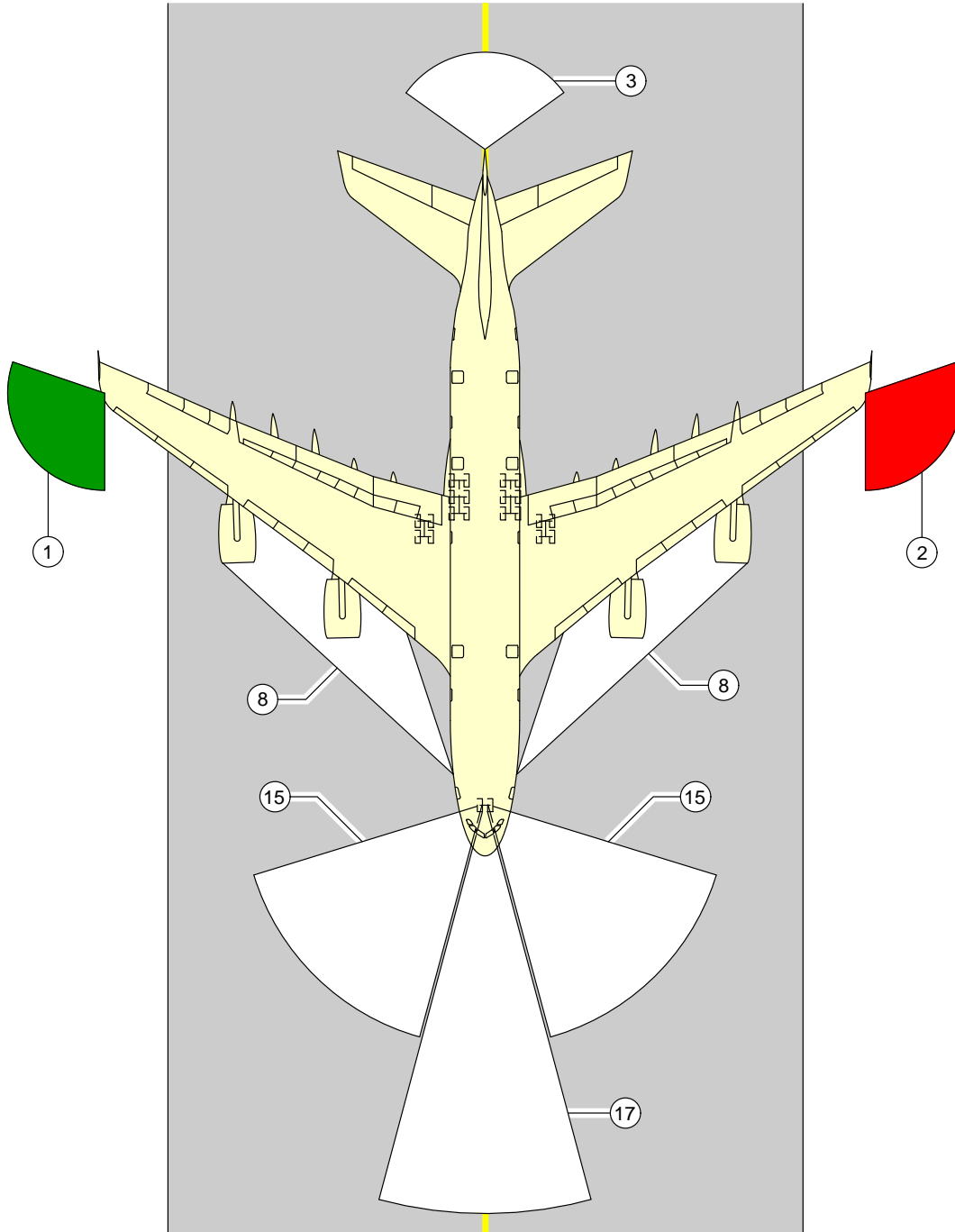

L_AC_021000_1_0090101_01_00

Exterior Lighting
FIGURE-2-10-0-991-009-A01

****ON A/C A380-800**

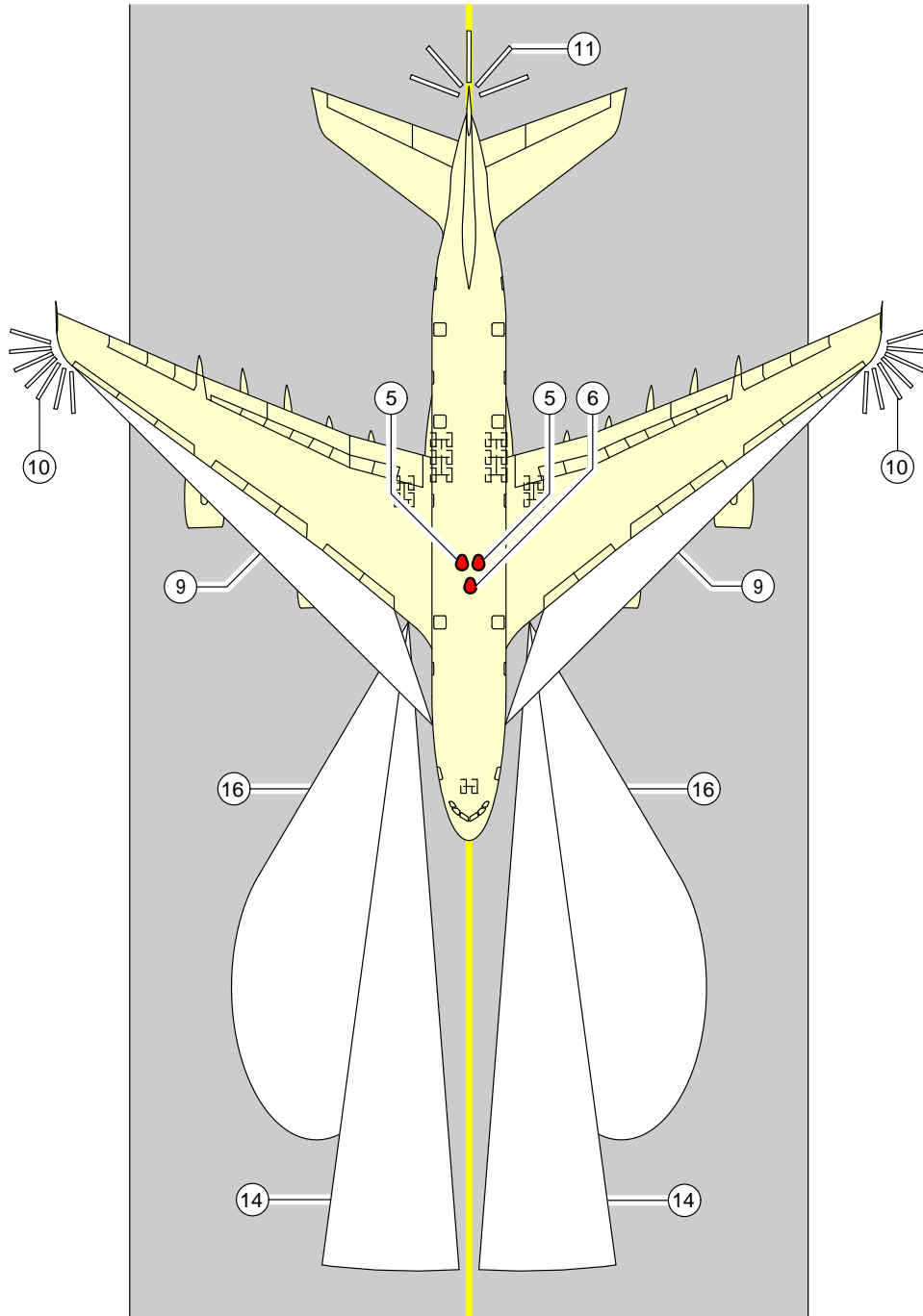

L_AC_021000_1_0100101_01_00

Exterior Lighting
FIGURE-2-10-0-991-010-A01

****ON A/C A380-800**

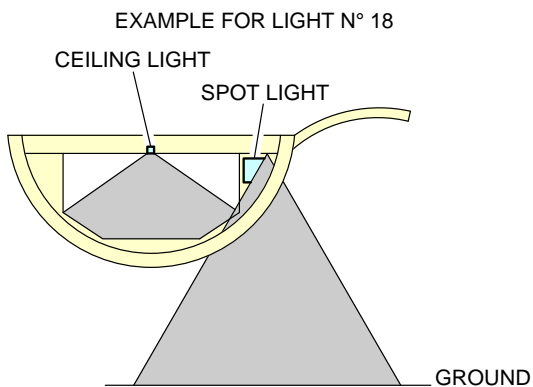
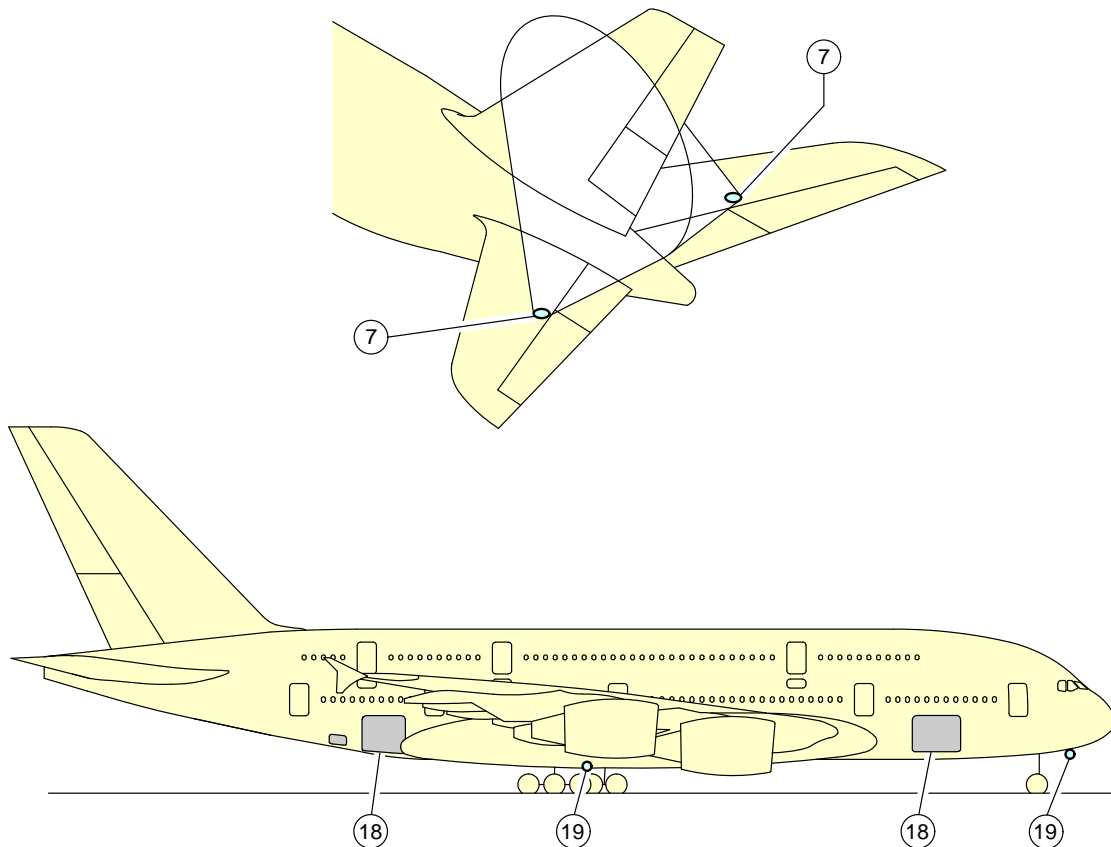

L_AC_021000_1_0110101_01_00

Exterior Lighting
FIGURE-2-10-0-991-011-A01

2-11-0 Antennas and Probes Location

****ON A/C A380-800**

Antennas and Probes Location

1. This section gives the location of antennas and probes.

****ON A/C A380-800**

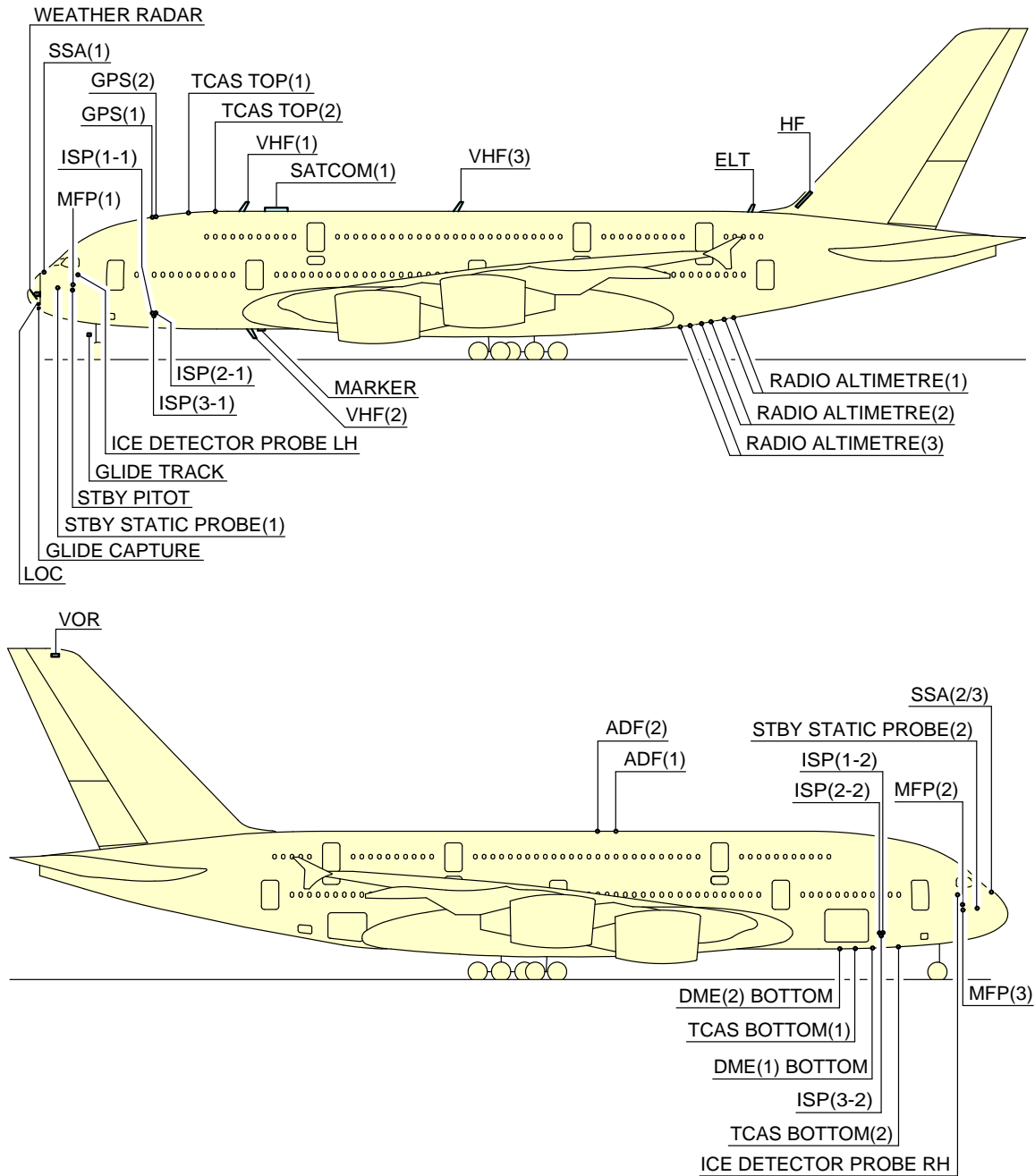

L_AC_021100_1_0010101_01_00

Antennas and Probes
Location
FIGURE-2-11-0-991-001-A01

2-12-0 Power Plant****ON A/C A380-800**Auxiliary Power Unit

1. General

- The APU is installed in the tail cone, at the rear part of the fuselage (Section 19.1), inside a fireproof compartment (between frames 112 and 117).
- The Air Intake System is located on top of the APU and crosses the space between the APU plenum chamber and the aircraft outside (upper right side position). The Air Intake Housing is located between frames 111 and 113 and the Air Intake Duct is located in the space between frames 113 and 115.
- The Exhaust Muffler is located at the end of the tail cone, aligned with the APU and crosses three different zones, from frame 116 to the rear fairing.
- The Electronic Control Box (ECB) is installed in an electronic cooled rack, closed to frame 95, within the pressurized fuselage.

2. Controls and Indication

Primary APU controls and indications are installed in the cockpit, mainly in the overhead panel, center pedestal panel and forward center panel. Additionally, two external emergency shutoff controls are installed on the Nose Landing Gear panel and on the Refuel/Defuel panel.

****ON A/C A380-800**

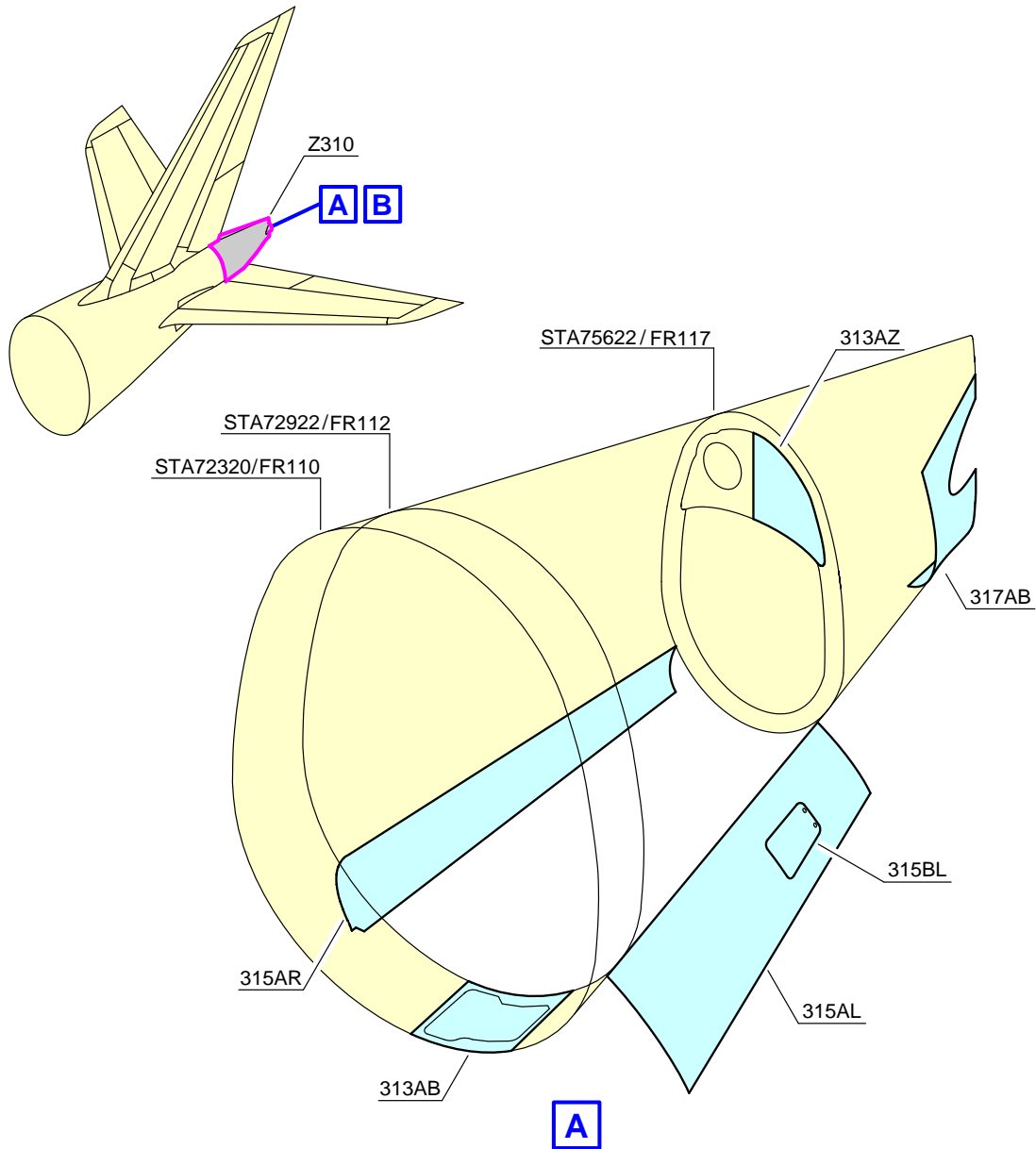

NOTE: THE DISTANCE FROM FR94, FR98, FR100 BOTTOM CENTERLINE TO FUSELAGE DATUM (FD) AS FOLLOWS:
 FR112 TO FD = 974.9 mm (38.38 in)
 FR117 TO FD = 1 772.4 mm (69.78 in)
 FR120 TO FD = 2 239.8 mm (88.18 in).

L_AC_021200_1_0010101_01_00

Auxiliary Power Unit
 Access Doors
 FIGURE-2-12-0-991-001-A01

****ON A/C A380-800**

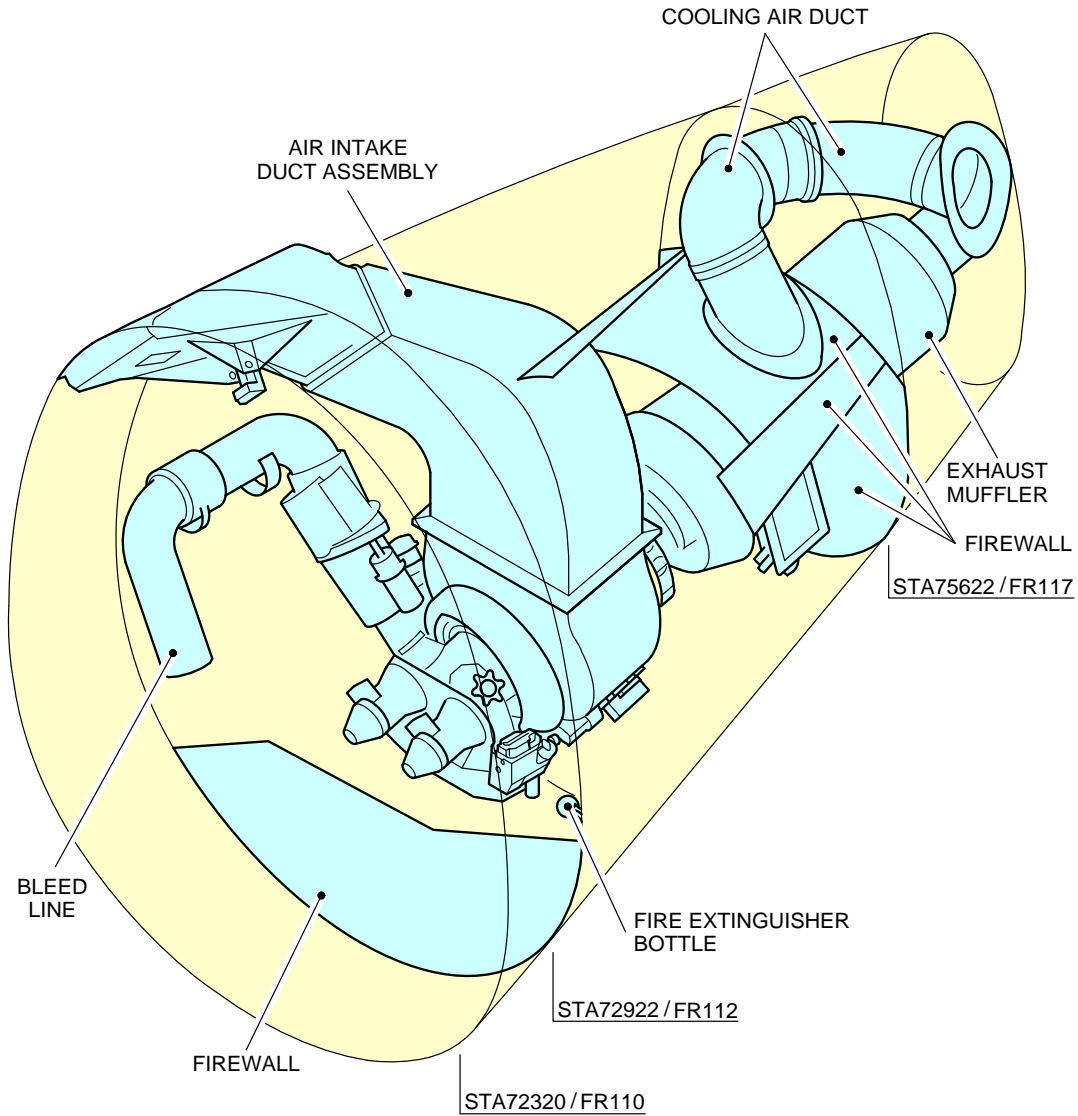

B

L_AC_021200_1_0020101_01_00

Auxiliary Power Unit
General Layout
FIGURE-2-12-0-991-002-A01

****ON A/C A380-800**Engine and Nacelle

1. Engine and Nacelle - GP 7200 Engine

A. Engine

The engine is a high by-pass ratio, two-rotor, axial flow turbofan engine with a high compression ratio. The Engine has Four Major Sections as Follows:

- compressor section
- combustion section
- turbine section
- accessory drive section.

The compressor section supplies High Pressure (HP) compressed air to the diffuser/burner for core engine thrust, aircraft service bleed systems, and by-pass air for thrust. A five-stage Low Pressure (LP) compressor rotor assembly is located to the rear of the fan rotor. An acoustic splitter fairing directs the primary airstream into the nine-stage HP compressor rotor assembly. The HP compressor has three stages of variable Inlet Guide Vanes (IGVs) and external bleeds from stages four, seven, and nine, with an internal bleed from stage six.

The combustion section receives compressed heated air from the HP compressor and fuel from the fuel nozzles. The mixture of hot air and fuel is ignited and burned in the single-annular combustion chamber to generate a HP stream of hot gas to turn the HP turbine and LP turbine.

The turbine section consists of HP turbine and LP turbine. The two-stage HP turbine rotor assembly receives the hot gas from the diffuser/burner. The HP turbine supplies the power to turn the HP compressor. The six-stage LP turbine has an active clearance control system for more efficient engine operation. The LP turbine provides the power to turn the LP compressor and fan rotor. The Turbine Exhaust Case (TEC) assembly supplies the structural support for the rear of the engine. The TEC straightens the exhaust gas flow as it exits the engine.

The accessory drive section consists of Main Gearbox (MGB) and Angle Gearbox (AGB). The MGB supplies the power to turn the attached engine and aircraft accessories. The AGB transmits the power from the engine rotor to the MGB. During engine start, the AGB transmits the power from the MGB to turn the engine rotor.

The LP rotor system is independent of the HP rotor system. The LP rotor system consists of the LP compressor and the LP turbine. The HP rotor system consists of the HP compressor and the HP turbine.

B. Nacelle

The Nacelle gives an aerodynamic shape to the engine and supports the thrust reverser system. Each engine is housed in a nacelle suspended from a pylon attached below the wing.

The nacelle consists of the following major components:

(1) Air Intake Cowl Assembly

The air intake cowl is an interchangeable aerodynamic cowl installed on the forward face of the engine fan case with bolts. It is designed to provide contour for airflow entering the engine and attenuates the fan noise.

(2) Fan Cowl Assembly

The fan-cowl doors are an assembly of aerodynamic cowls attached to the aircraft pylon structure through its hinges. It is installed between the air intake cowl and the fan exhaust cowl/thrust reverser, around the engine fan case. It is composed of two semicircular panels, the left and the right fan cowl door.

(3) Thrust Reverser

The thrust reverser assembly is installed at the aft part of the nacelle. The thrust reverser cowls are installed on the aircraft inboard engines. It is attached to the wing pylon by hinges. The thrust reverser assembly is a standard fixed cascade, translating cowl and blocker door type thrust reverser. It is only installed on the aircraft inboard position nacelles. It is made of two halves that make a duct around the engine. Each half consists of a fixed structure, which gives support for the cascades and actuation system and a translating cowl.

The thrust reverser assembly encloses the engine core with an aerodynamic flow path and uses the outer translating cowl to give a fan exhaust duct and nozzle exit.

In stow mode, the thrust reverser is an aerodynamic structure that adds to the engine thrust generation.

In reverse mode, it is used to turn and direct the fan exhaust air in the forward direction using blocker door through the cascades. The thrust reverser increases the aircraft braking function in order to reduce the landing or aborted take-off distance, especially on a contaminated runway.

(4) Fan Exhaust Cowl Assembly

The fan exhaust cowls is a component of the aircraft propulsion system nacelle. It is installed at the aft part of the nacelle. The fan exhaust cowls are installed on the aircraft outboard engines.

The fan exhaust cowls are attached to the wing pylon by hinges. The two halves of the fan exhaust cowl close the engine core with an aerodynamic flow path.

The fan exhaust structure has two half-cowls hinged at the top to the wing pylon and latched together at the bottom centerline. Its forward end is secured on the aft of the fan case and aft of the intermediate engine case.

(5) Exhaust System

The primary air flow is the part of the air absorbed by the engine that enters into the engine combustor and that is exhausted to atmosphere through the turbine exhaust system.

The turbine exhaust flow path is formed by the inner wall of the exhaust nozzle and the outer wall of the exhaust plug.

The secondary air flow is the part of the air absorbed by the fan that bypasses the core engine and flows through the thrust reverser and fan exhaust cowl directly to the atmosphere.

2. Engine and Nacelle -TRENT 900 Engine

A. Engine

The RB211-TRENT 900 engine is a high by-pass ratio, triple spool turbo-fan.

The principal modules of the engine are:

- Low Pressure Compressor (LPC) rotor
- Intermediate Pressure (IP) compressor
- Intermediate case
- HP system (this includes the High Pressure Compressor (HPC), the combustion system and the High Pressure Turbine (HPT))
- IP turbine
- external gearbox
- LPC case
- Low Pressure Turbine (LPT)

The Intermediate Pressure (IP) and Low Pressure Compressor (LPC)/Low Pressure Turbine (LPT) assemblies turn in a counter clockwise direction and the High Pressure Compressor (HPC)/ High Pressure Turbine (HPT) assembly turns in a clockwise direction (when seen from the rear of the engine) during engine operation.

The compressors increase the pressure of the air, which flows through the engine. The necessary power to turn the compressors is supplied by turbines.

The LP system has a one-stage compressor installed at the front of the engine. A shaft connects the single-stage LPC to a five-stage axial flow turbine at the rear of the gas generator. The gas generator also includes an eight-stage IP compressor, a six-stage HPC and a combustion system. Each of the compressors in the gas generator is connected to, and turned by, a different turbine. Between the HPC and the HPT is the annular combustion system which burns a mixture of fuel and air to supply energy as heat. Behind the LPT there is a collector nozzle assembly through which the hot gas exhaust flows.

B. Nacelle

A nacelle gives the engine an aerodynamic shape and supports the thrust reverser system. Each engine is housed in a nacelle suspended from a pylon attached below the wing.

The nacelle consists of the following major components:

- (1) Air Intake Cowl Assembly

The air intake cowl is an interchangeable aerodynamic cowl installed at the front of the engine. It ducts the airflow to the fan and the engine core. The cowl has panels for easy access to the components. Acoustic materials are used in the manufacture of the cowl to help decrease the engine noise.

(2) Fan Cowl Assembly

The fan cowl assembly has two semicircular panels, the left fan cowl door and the right fan cowl door. The installation of the fan cowl doors is around the engine fan case between the air intake cowl and the thrust reverser cowl.

The fan Cowl Opening System (COS) have two electrical actuators which open or close the fan cowls. Personnel operate the actuators from the ground only during engine maintenance operations. The personnel use a switch box located on the air intake cowl.

(3) Thrust Reverser

The thrust reverser assembly is installed at the aft part of the nacelle. The thrust reversers are installed on the aircraft inboard engines. It is attached to the wing pylon by hinges. The thrust reverser assembly is a standard fixed cascade, translating cowl and blocker door type thrust-reverser. It is only installed on the aircraft inboard engine nacelles. It is made of two halves that make a duct around the engine. Each half has a fixed structure that holds the cascades, the actuation system and a translating cowl.

The thrust reverser assembly closes the engine core with an aerodynamic flow path and uses the outer translating cowl to make a fan exhaust duct and nozzle exit.

In stow mode, the thrust reverser is an aerodynamic structure that makes the engine thrust.

In reverse mode, it changes the direction of the fan exhaust air in the forward direction by use of the blocker doors through the cascades. The thrust reverser increases the aircraft braking and speed braking function in order to decrease the landing or aborted take-off distance, especially on a dirty runway.

(4) Fan Exhaust Cowl Assembly

The fan exhaust cowl is a component of the aircraft engine nacelle. It is installed at the aft part of the nacelle. The fan exhaust structures are installed on the aircraft outboard engines. They are attached to the wing pylon by hinges. The left and right fan exhaust structures closed the engine core with an aerodynamic flow path. The structure gives a fire protection and a support for the aerodynamic, inertial and engine loads.

The fan exhaust structure has left and right cowls hinged at the top to the wing pylon and latched together at the bottom centerline. Its forward end is attached at the aft of the fan case.

(5) Exhaust System

Primary air is the part of the air absorbed by the fan that enters the engine near the fan blade platform, continues through the Low Pressure (LP) and High Pressure (HP) compressors, the combustor, and the HP and LP turbines, and is accelerated and exhausted to the atmosphere through the turbine exhaust system.

The turbine exhaust flow path is formed by the inner surface of the exhaust nozzle and the outer surface of the exhaust plug.

Secondary air is the part of the air absorbed by the fan that is directly discharged from the outer portion of the fan, by-passes the core engine and flows through the fan exhaust to the atmosphere.

****ON A/C A380-800**

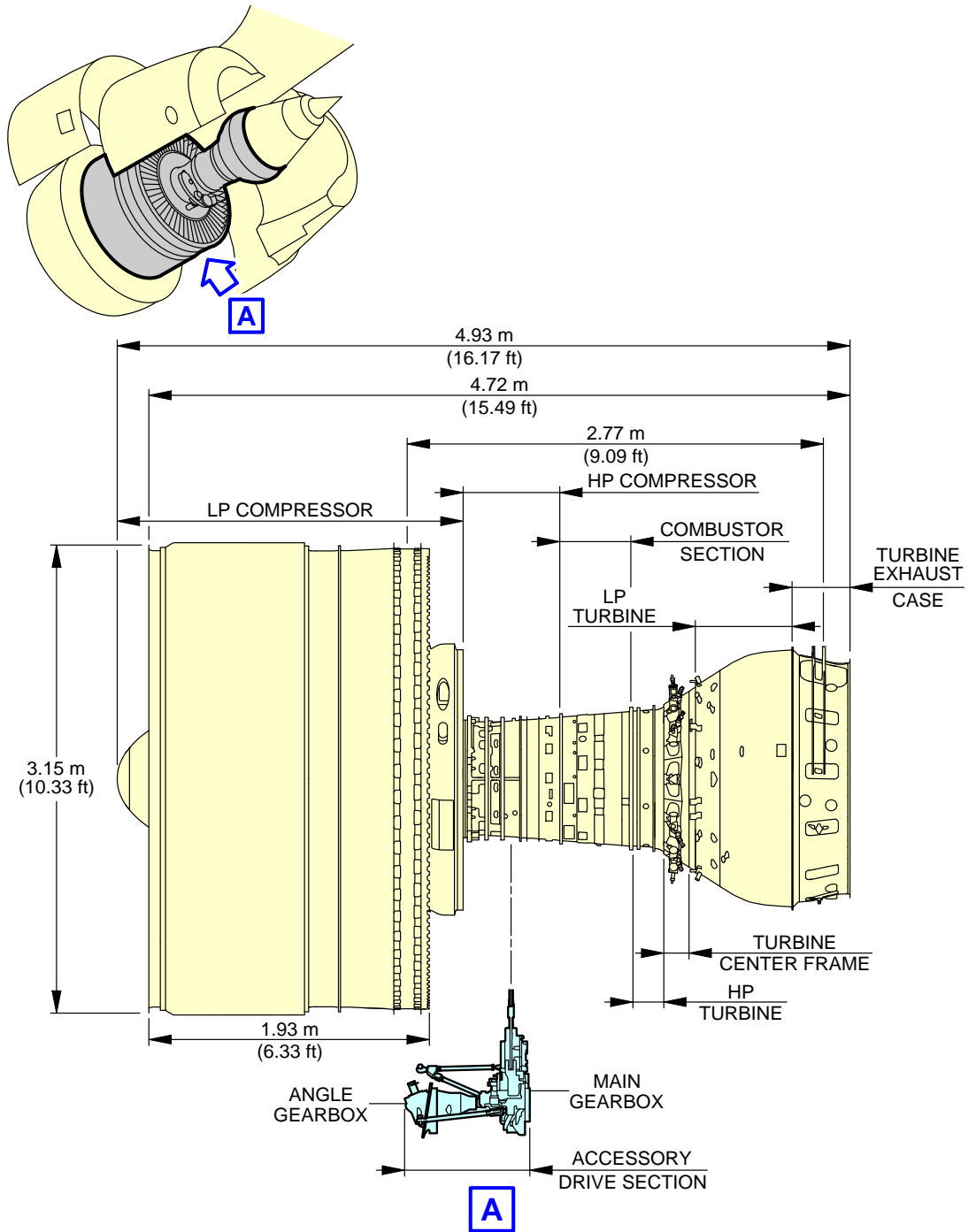

L_AC_021200_1_0030101_01_00

Power Plant Handling
Engine Dimensions - GP 7200 Engine
FIGURE-2-12-0-991-003-A01

****ON A/C A380-800**

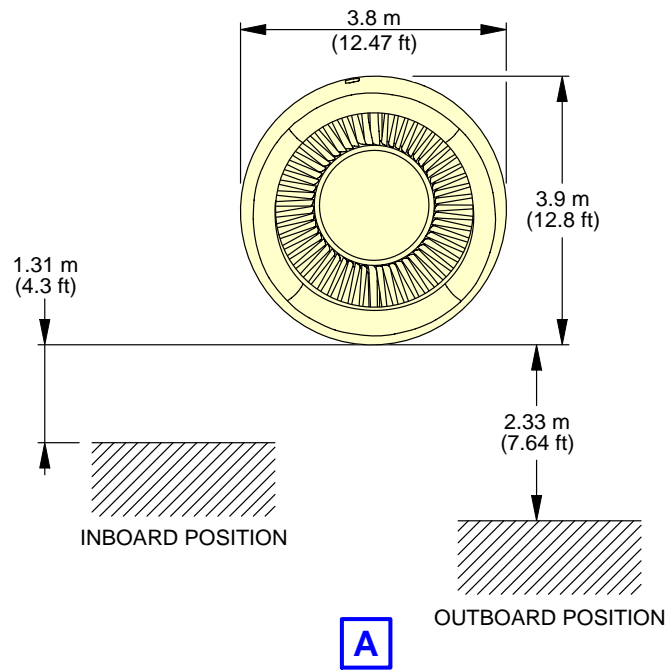
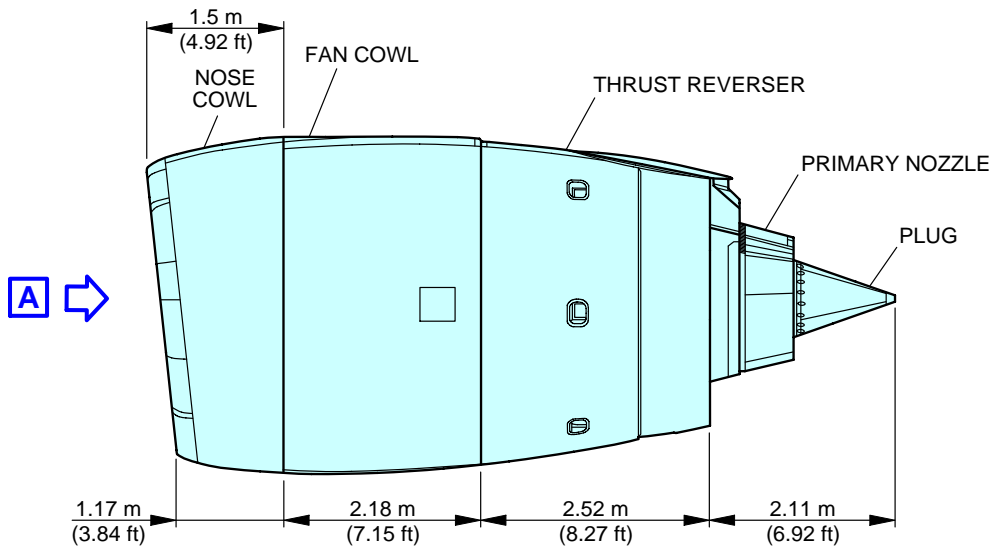

L_AC_021200_1_0040101_01_00

Power Plant Handling
Nacelle Dimensions - GP 7200 Engine
FIGURE-2-12-0-991-004-A01

****ON A/C A380-800**

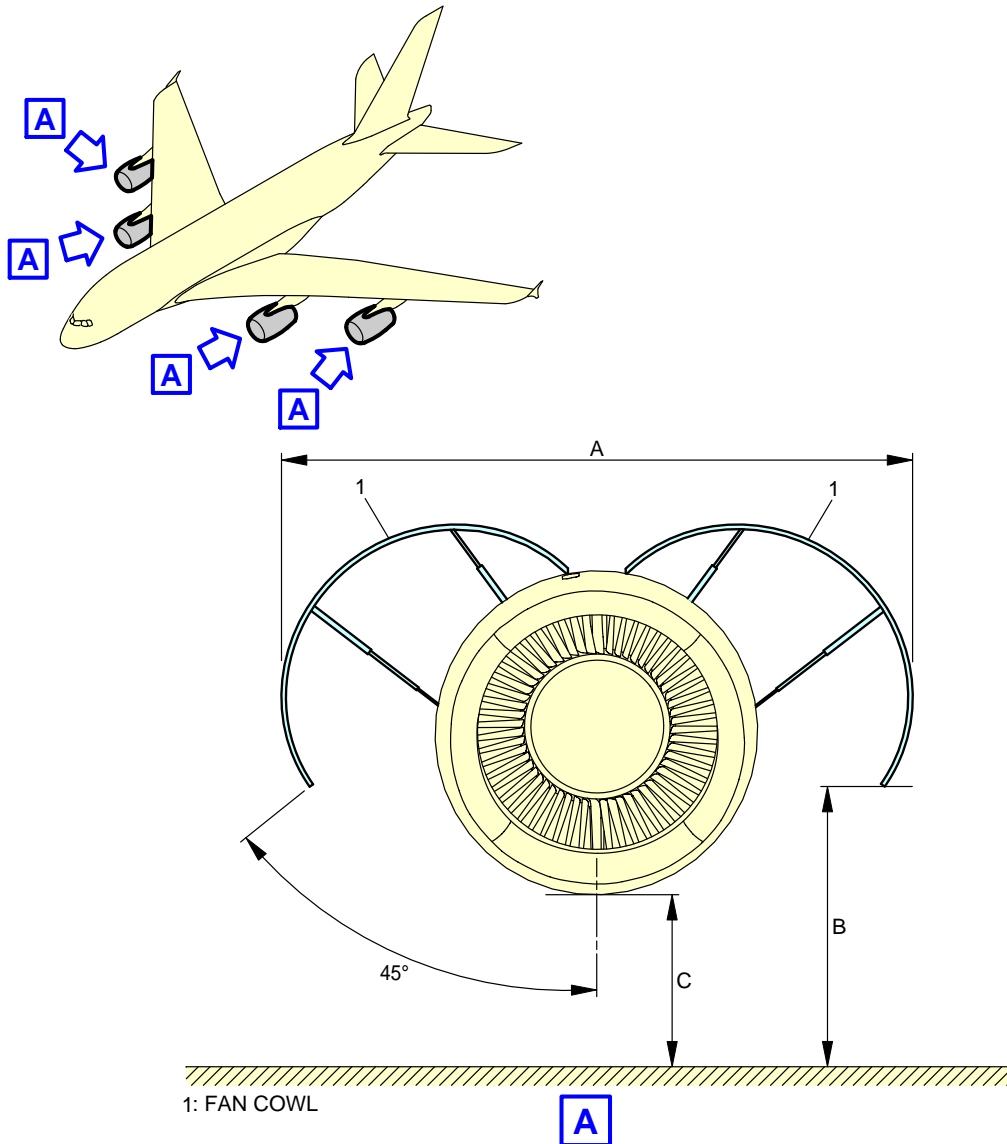

OPEN POSITION	A	B				C
		ENGINE 1-4		ENGINE 2-3		
	MIN.	MAX.	MIN.	MAX.		
45°	6.8 m (22.31 ft)	2.64 m (8.66 ft)	3.14 m (10.3 ft)	1.86 m (6.1 ft)	2.16 m (7.09 ft)	SEE AC SECTION 2-3-0

NOTE: B AND C DEPENDING ON AIRCRAFT CONFIGURATION.

L_AC_021200_1_0050101_01_00

Power Plant Handling
Fan Cowls - GP 7200 Engine
FIGURE-2-12-0-991-005-A01

****ON A/C A380-800**

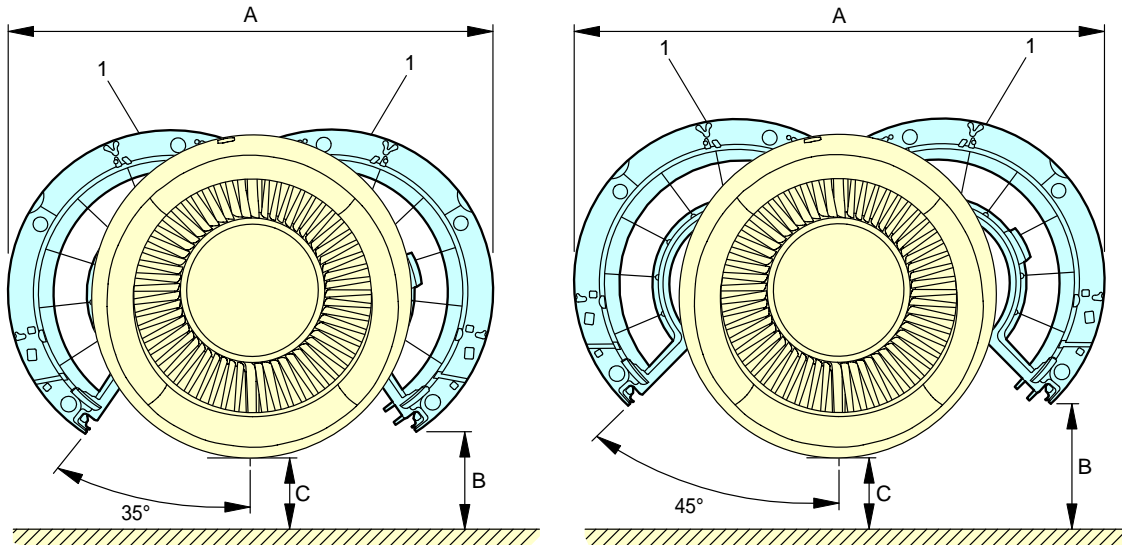
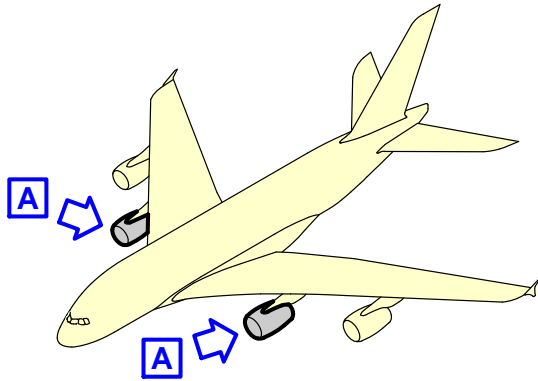

1: THRUST REVERSER

A

OPEN POSITION	A	B		C
		MIN.	MAX.	
35°	5.8 m (19.03 ft)	1.52 m (4.99 ft)	1.82 m (5.97 ft)	SEE AC SECTION 2-3-0
45°	6.32 m (20.73 ft)	1.86 m (6.1 ft)	2.16 m (7.09 ft)	

NOTE: B AND C DEPENDING ON AIRCRAFT CONFIGURATION.

L_AC_021200_1_0060101_01_00

Power Plant Handling
Thrust Reverser Cowls - GP 7200 Engine
FIGURE-2-12-0-991-006-A01

****ON A/C A380-800**

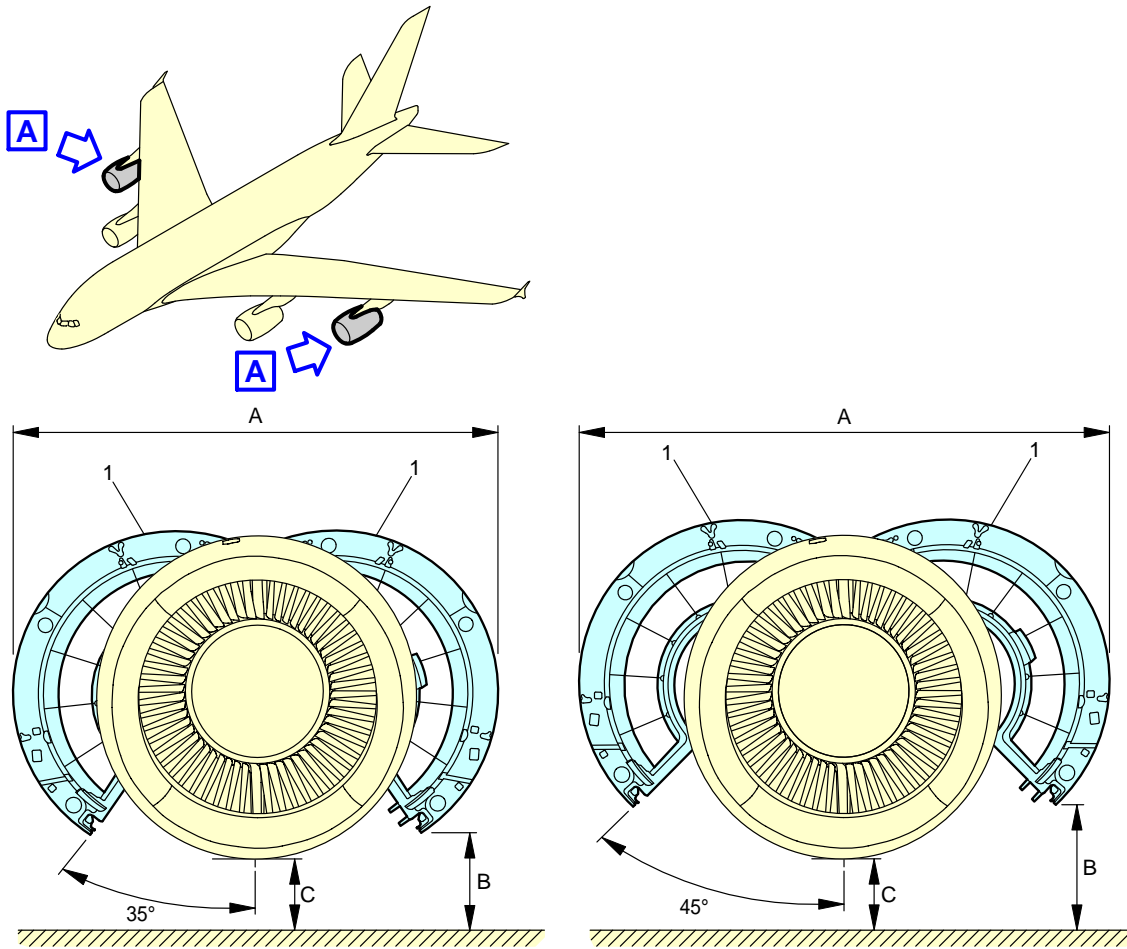

1: FAN EXHAUST COWL

A

OPEN POSITION	A	B		C
		MIN.	MAX.	
35°	5.8 m (19.03 ft)	2.3 m (7.55 ft)	2.8 m (9.19 ft)	SEE AC SECTION 2-3-0
45°	6.32 m (20.73 ft)	2.64 m (8.66 ft)	3.14 m (10.3 ft)	

NOTE: B AND C DEPENDING ON AIRCRAFT CONFIGURATION.

L_AC_021200_1_0070101_01_01

Power Plant Handling
Fan Exhaust Cowls - GP 7200 Engine
FIGURE-2-12-0-991-007-A01

****ON A/C A380-800**

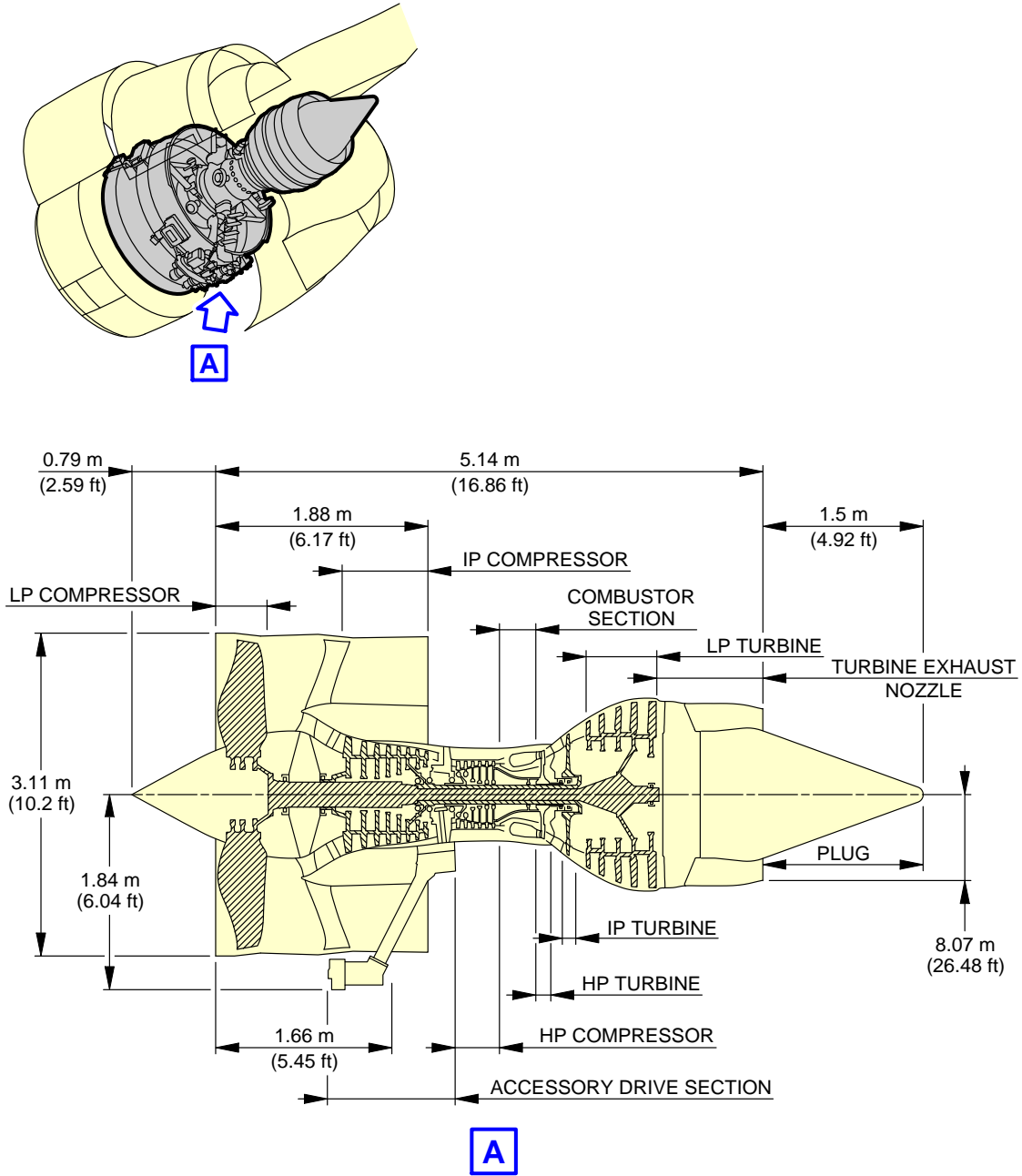

L_AC_021200_1_0080101_01_00

Power Plant Handling
 Engine Dimensions - TRENT 900 Engine
 FIGURE-2-12-0-991-008-A01

****ON A/C A380-800**

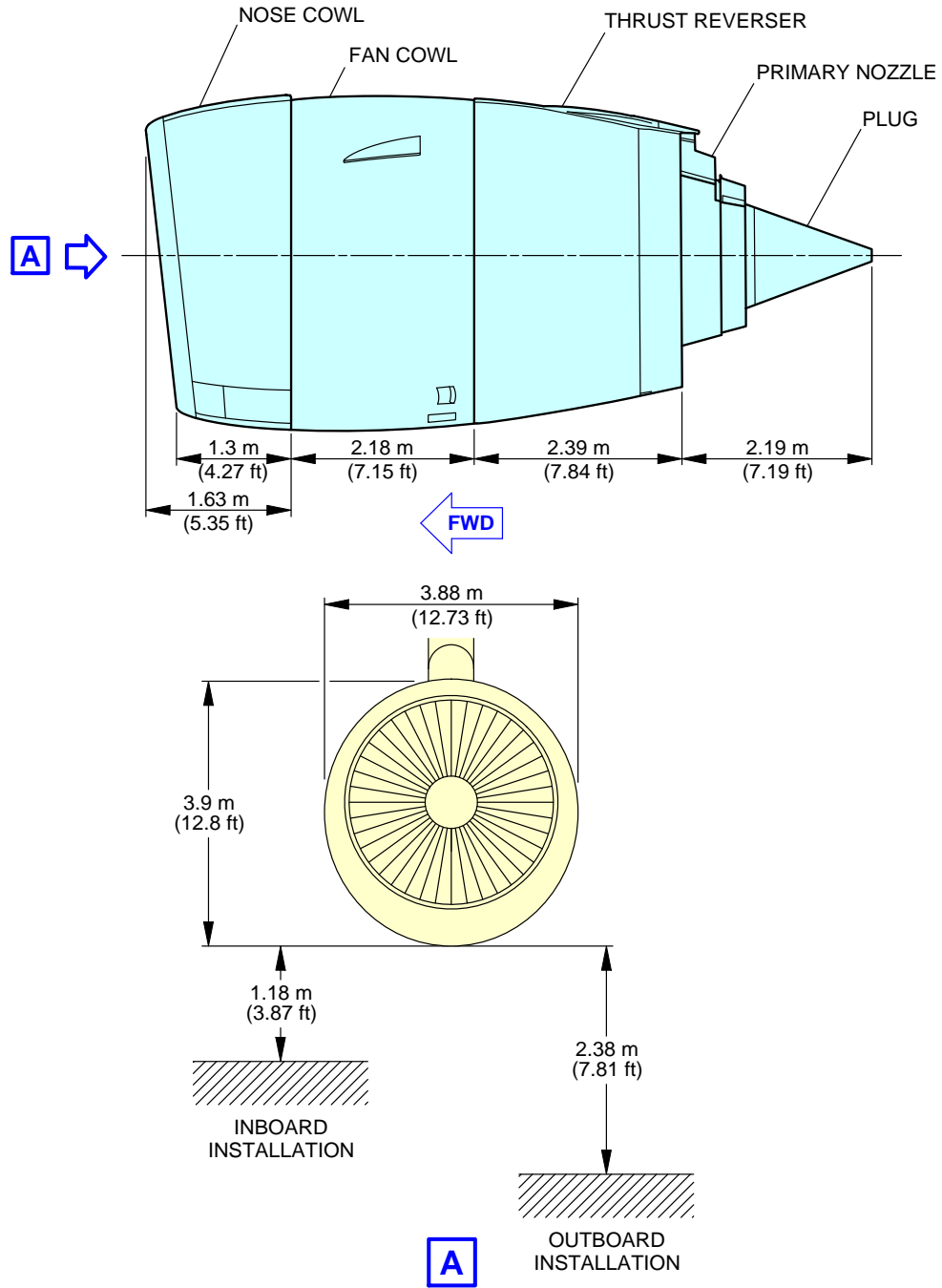

L_AC_021200_1_0090101_01_00

Power Plant Handling
 Nacelle Dimensions - TRENT 900 Engine
 FIGURE-2-12-0-991-009-A01

****ON A/C A380-800**

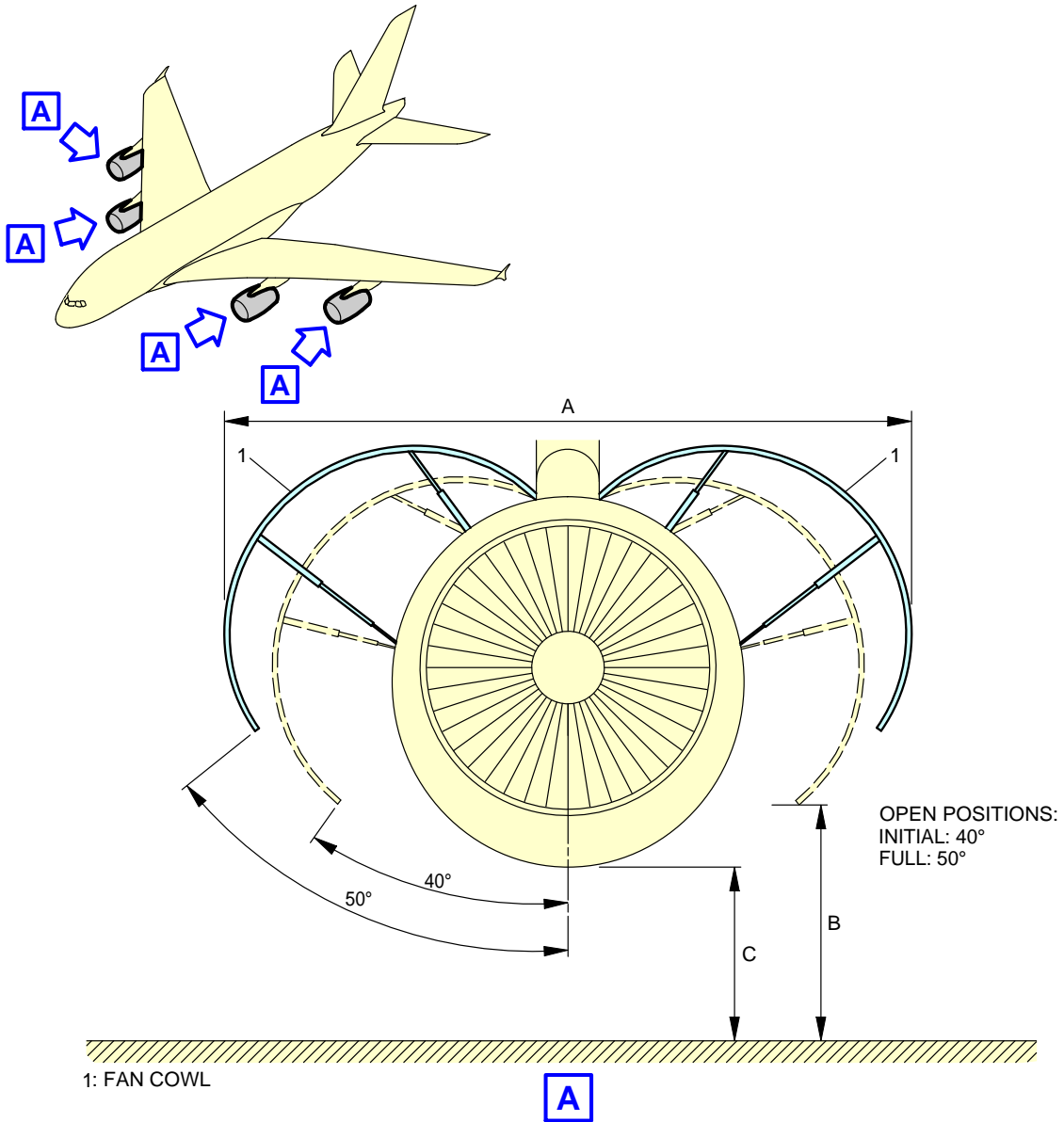

OPEN POSITION	A	B		C	
	ALL ENG.	INBOARD ENG.	OUTBOARD ENG.	INBOARD ENG.	OUTBOARD ENG.
40°	6.95 m (22.8 ft)	2 m (6.56 ft)	3 m (9.84 ft)	1.3 m (4.27 ft)	2.27 m (7.45 ft)
50°	7.3 m (23.95 ft)	2.4 m (7.87 ft)	3.4 m (11.15 ft)	1.3 m (4.27 ft)	2.27 m (7.45 ft)

L_AC_021200_1_0100101_01_00

Power Plant Handling
Fan Cows - TRENT 900 Engine
FIGURE-2-12-0-991-010-A01

****ON A/C A380-800**

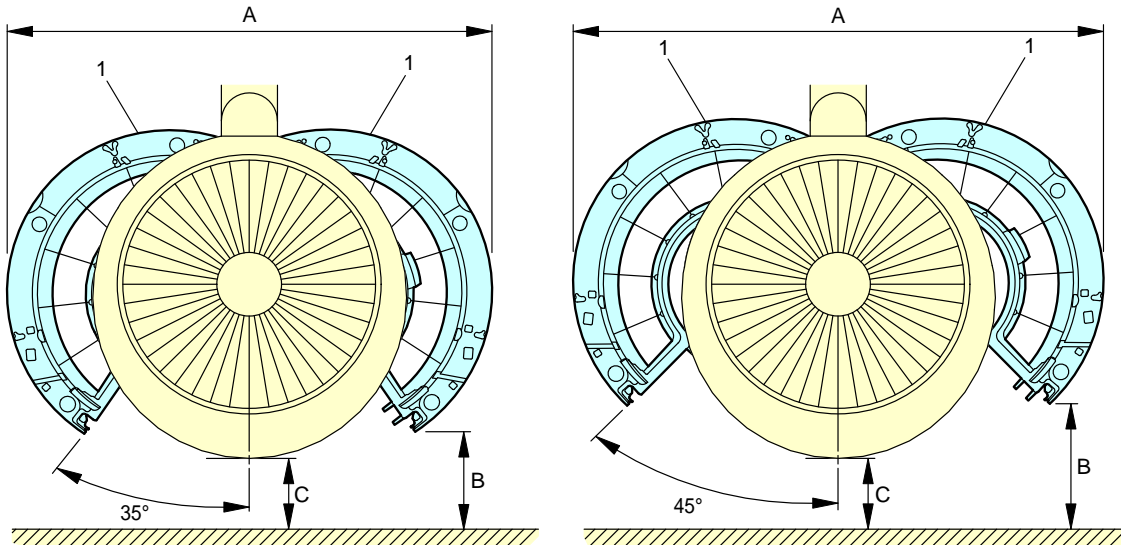
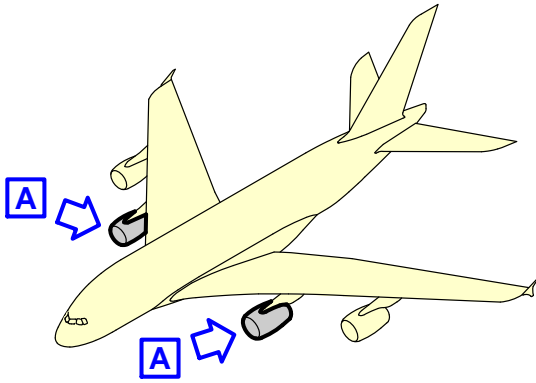

1: THRUST REVERSER

A

OPEN POSITION	A	B		C
		MIN.	MAX.	
35°	5.8 m (19.03 ft)	1.52 m (4.99 ft)	1.82 m (5.97 ft)	SEE AC SECTION 2-3-0
45°	6.32 m (20.73 ft)	1.86 m (6.1 ft)	2.16 m (7.09 ft)	

NOTE: B AND C DEPENDING ON AIRCRAFT CONFIGURATION.

L_AC_021200_1_0110101_01_00

Power Plant Handling
Thrust Reverser Cowls - TRENT 900 Engine
FIGURE-2-12-0-991-011-A01

****ON A/C A380-800**

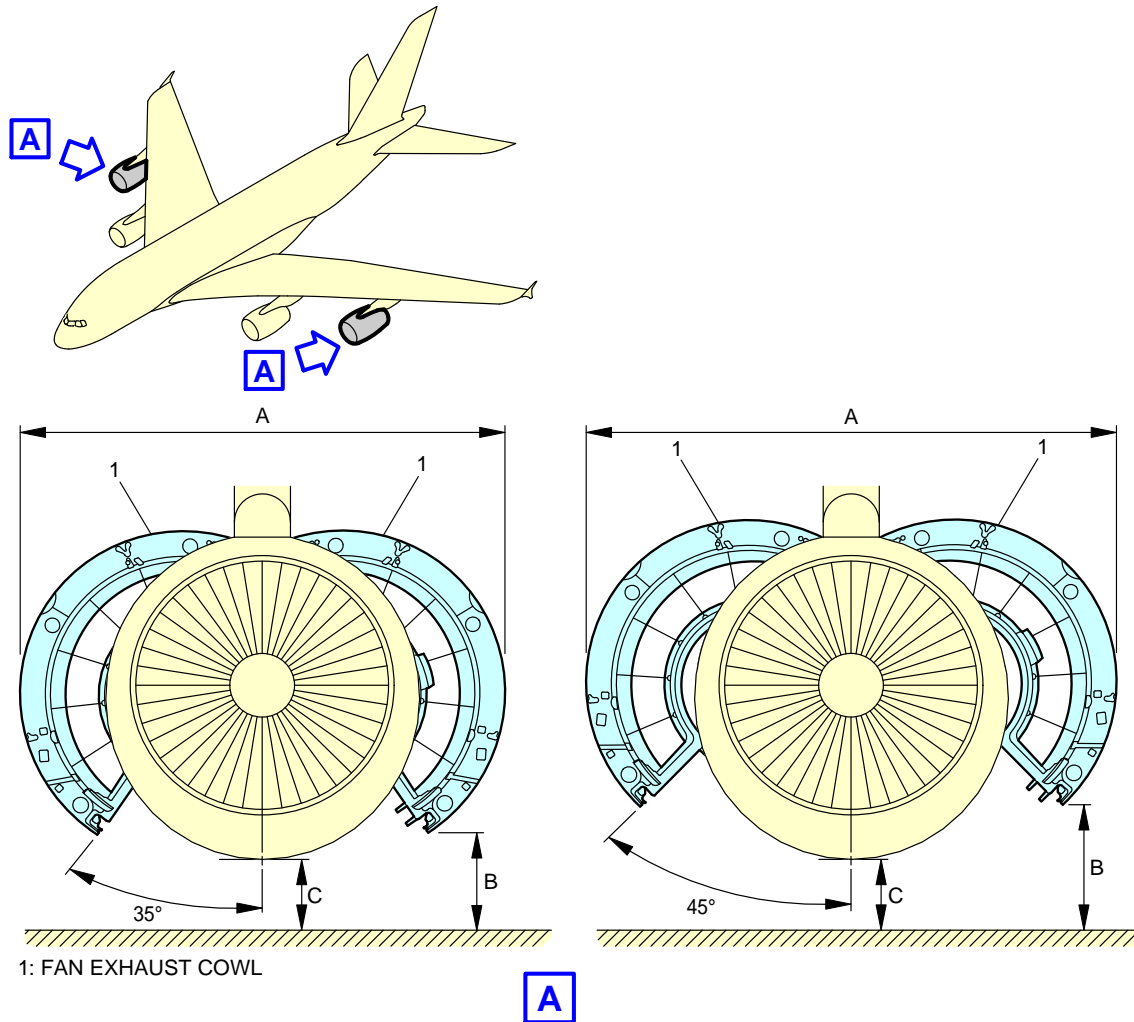

OPEN POSITION	A	B		C
		MIN.	MAX.	
35°	5.8 m (19.03 ft)	2.3 m (7.55 ft)	2.8 m (9.19 ft)	SEE AC SECTION 2-3-0
45°	6.32 m (20.73 ft)	2.64 m (8.66 ft)	3.14 m (10.3 ft)	

NOTE: B AND C DEPENDING ON AIRCRAFT CONFIGURATION.

L_AC_021200_1_0120101_01_01

Power Plant Handling
Fan Exhaust Cowls - TRENT 900 Engine
FIGURE-2-12-0-991-012-A01

2-13-0 Leveling, Symmetry and Alignment

****ON A/C A380-800**

Leveling, Symmetry and Alignment

1. Quick Leveling

There are three alternative procedures to level the aircraft:

- Quick leveling procedure with Air Data/Inertial Reference System (ADIRS).
- Quick leveling procedure with a spirit level in the upper or main deck passenger compartment.
- Quick leveling procedure with a spirit level in the FWD cargo compartment.

2. Precise Leveling

For precise leveling, it is necessary to install sighting rods in the receptacles located under the fuselage (points 11 and 16 for longitudinal leveling) and under the wings (points 1L and 1R for lateral leveling) and use a sighting tube. With the aircraft on jacks, adjust the jacks until the reference marks on the sighting rods are aligned in the sighting plane (aircraft level).

3. Symmetry and Alignment Check

Possible deformation of the aircraft is measured by photogrammetry.

****ON A/C A380-800**

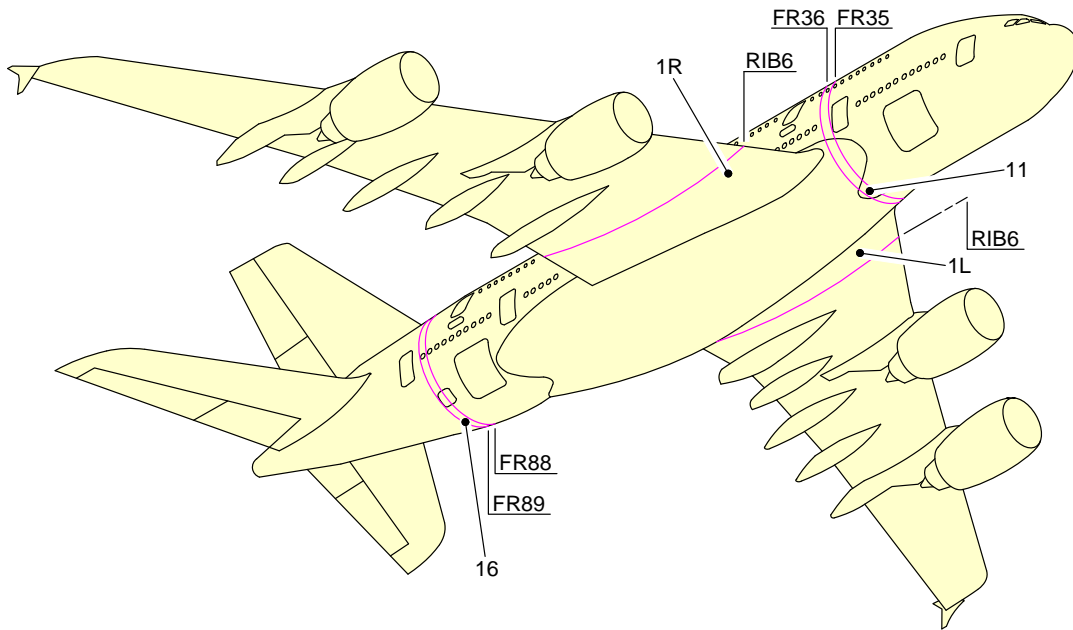

L_AC_021300_1_0010101_01_00

Location of Leveling Points
FIGURE-2-13-0-991-001-A01

2-14-0 Jacking

****ON A/C A380-800**

Jacking for Maintenance

1. Aircraft Jacking Points for Maintenance

A. General

(1) The A380-800 can be jacked:

- At not more than 333 700 kg (735 682 lb),
- Within the limits of the permissible wind speed when the aircraft is jacked outside a closed environment.

B. Primary Jacking Points

(1) The aircraft is provided with three primary jacking points:

- One located under the forward fuselage,
- Two located under the wings (one under each wing).

(2) Three jack adapters (ground equipment) are used as intermediary parts between the aircraft jacking points and the jacks:

- One male spherical jack adapter at the forward fuselage,
- Two female spherical jack pad adapters at the wings (one at each wing).

C. Auxiliary Jacking Point (Safety Stay)

(1) When the aircraft is on jacks, a safety stay is installed under the AFT fuselage (Ref. FIGURE 2-14-0-991-001-A) to prevent tail tipping caused by accidental displacement of the aircraft center of gravity.

(2) The safety point must not be used for lifting the aircraft.

(3) One male spherical stay adapter (ground equipment) is used as an intermediary part between the aircraft safety point and the stay.

2. Jacks and Safety Stay

A. Jack Design

(1) The maximum eligible loads given in the table (Ref. FIGURE 2-14-0-991-001-A) are the maximum loads applicable on jack fittings.

- (2) In fully retracted position (jack stroke at minimum), the height of the jacks is such that the jack may be placed beneath the aircraft under the most adverse conditions, namely, tires deflated and shock absorbers depressurized, with sufficient clearance between the aircraft jacking point and the jack upper end.
- (3) The jacks stroke enables the aircraft to be jacked up so that the Fuselage Datum Line (FDL) may be positioned up to 7 200 mm (283.46 in) from the ground to allow all required maintenance procedures and in particular, the removal/installation of the landing-gear shock absorbers.

B. Safety Stay

- (1) The stay stroke enables the aircraft tail to be supported up to the Fuselage Datum Line (FDL) positioned 7 200 mm (283.46 in) from the ground.

****ON A/C A380-800**

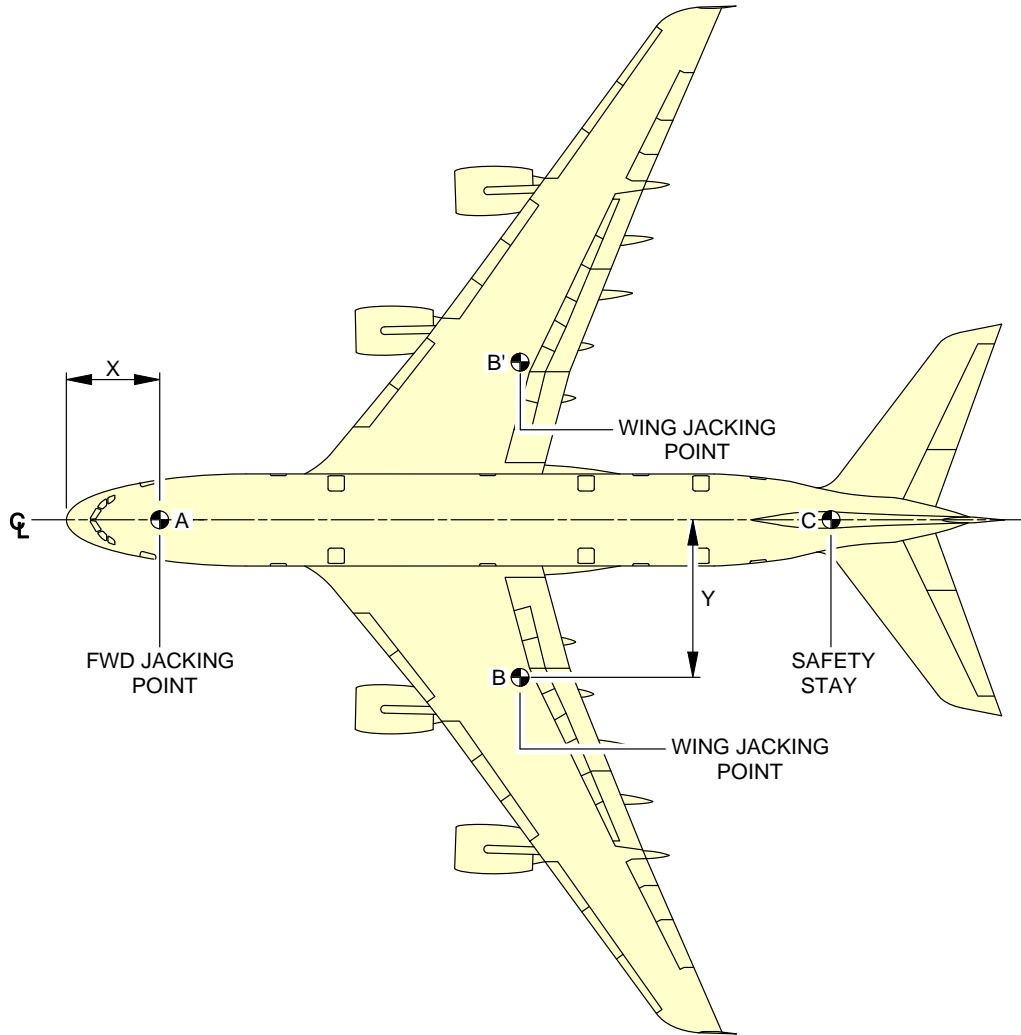

		X		Y		MAXIMUM LOAD ELIGIBLE daN
		m	ft	m	ft	
FORWARD FUSELAGE JACKING POINT	A	7.29	23.92	0	0	34 011
WING JACKING POINT	B	35.23	115.58	12.22	40.09	157 480
	B'	35.23	115.58	-12.22	-40.09	157 480
SAFETY STAY	C	59.34	194.68	0	0	7 874

NOTE: SAFETY STAY IS NOT USED FOR JACKING.

L_AC_021400_1_0010101_01_00

Jacking for Maintenance
Jacking Points Location
FIGURE-2-14-0-991-001-A01

****ON A/C A380-800**

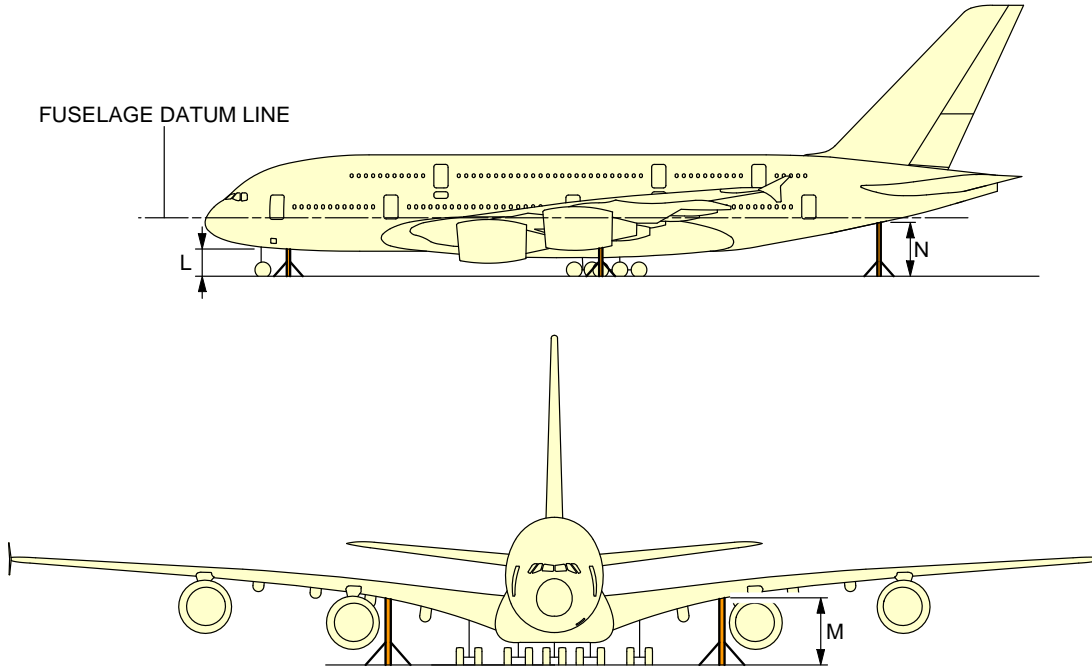

	L	M	N
AIRCRAFT ON WHEELS WITH STANDARD TIRES, MAX. JACK WEIGHT 333 700 kg (735 682 lb)	2 472 mm (97.32 in)	5 112 mm (201.26 in)	4 707 mm (185.31 in)
AIRCRAFT ON WHEELS, SHOCK ABSORBERS DEFLATED AND TIRES FLAT	2 259 mm (88.94 in)	4 788 mm (188.5 in)	4 462 mm (175.67 in)
AIRCRAFT ON WHEELS, NOSE LANDING GEAR SHOCK ABSORBERS DEFLATED AND TIRES FLAT	2 296 mm (90.39 in)	5 117 mm (201.46 in)	5 044 mm (198.58 in)
AIRCRAFT ON WHEELS, LEFT WING AND BODY LANDING GEARS SHOCK ABSORBERS DEFLATED AND TIRES FLAT (SAME DATA FOR RIGHT SIDE CONDITIONS)	2 474 mm (97.4 in)	4 523 mm (178.07 in)	4 257 mm (167.6 in)
AIRCRAFT ON WHEELS, WING AND BODY LANDING GEARS SHOCK ABSORBERS DEFLATED AND TIRES FLAT	2 391 mm (94.13 in)	4 803 mm (189.09 in)	4 291 mm (168.94 in)
AIRCRAFT ON JACKS, FUSELAGE DATUM LINE PARALLEL TO GROUND AT 6 350 mm (250 in) FOR LANDING GEARS EXTENSION/RETRACTION	3 673 mm (144.61 in)	6 158 mm (242.44 in)	5 830 mm (229.53 in)
AIRCRAFT ON JACKS, FUSELAGE DATUM LINE PARALLEL TO GROUND AT 7 200 mm (283.46 in) FOR LANDING GEARS REMOVAL/INSTALLATION	4 523 mm (178.07 in)	7 008 mm (275.91 in)	6 680 mm (262.99 in)
AIRCRAFT JACKED AT FORWARD JACKING POINT, WING AND BODY LANDING GEARS WHEELS ON THE GROUND, FOR NOSE LANDING GEAR EXTENSION/RETRACTION TEST	4 523 mm (178.07 in)	N/A	2 910 mm (114.57 in)

L_AC_021400_1_0020101_01_01

Jacking for Maintenance
Jacking Dimensions
FIGURE-2-14-0-991-002-A01

****ON A/C A380-800**

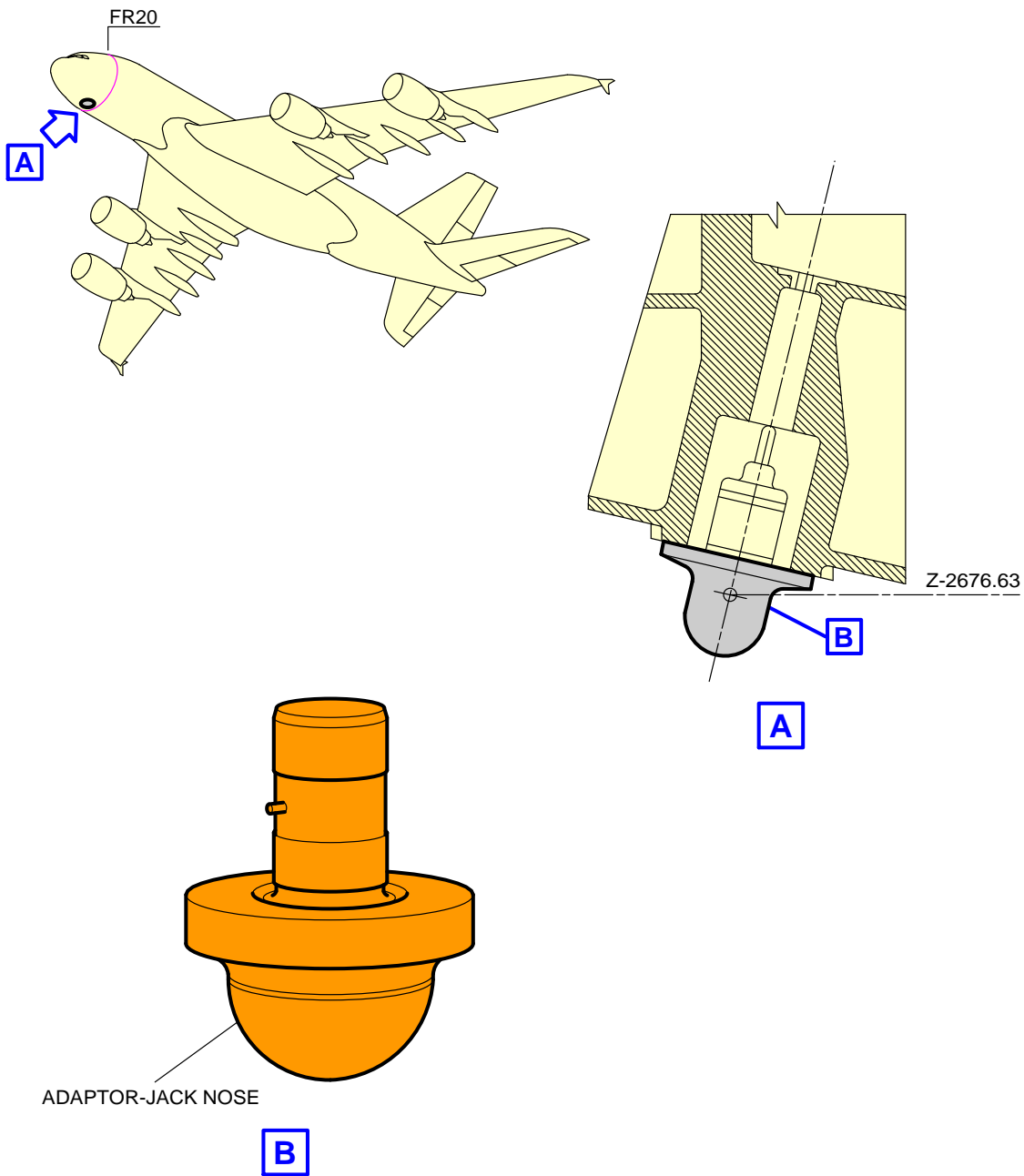

L_AC_021400_1_0030101_01_00

Jacking for Maintenance
Forward Jacking Point
FIGURE-2-14-0-991-003-A01

****ON A/C A380-800**

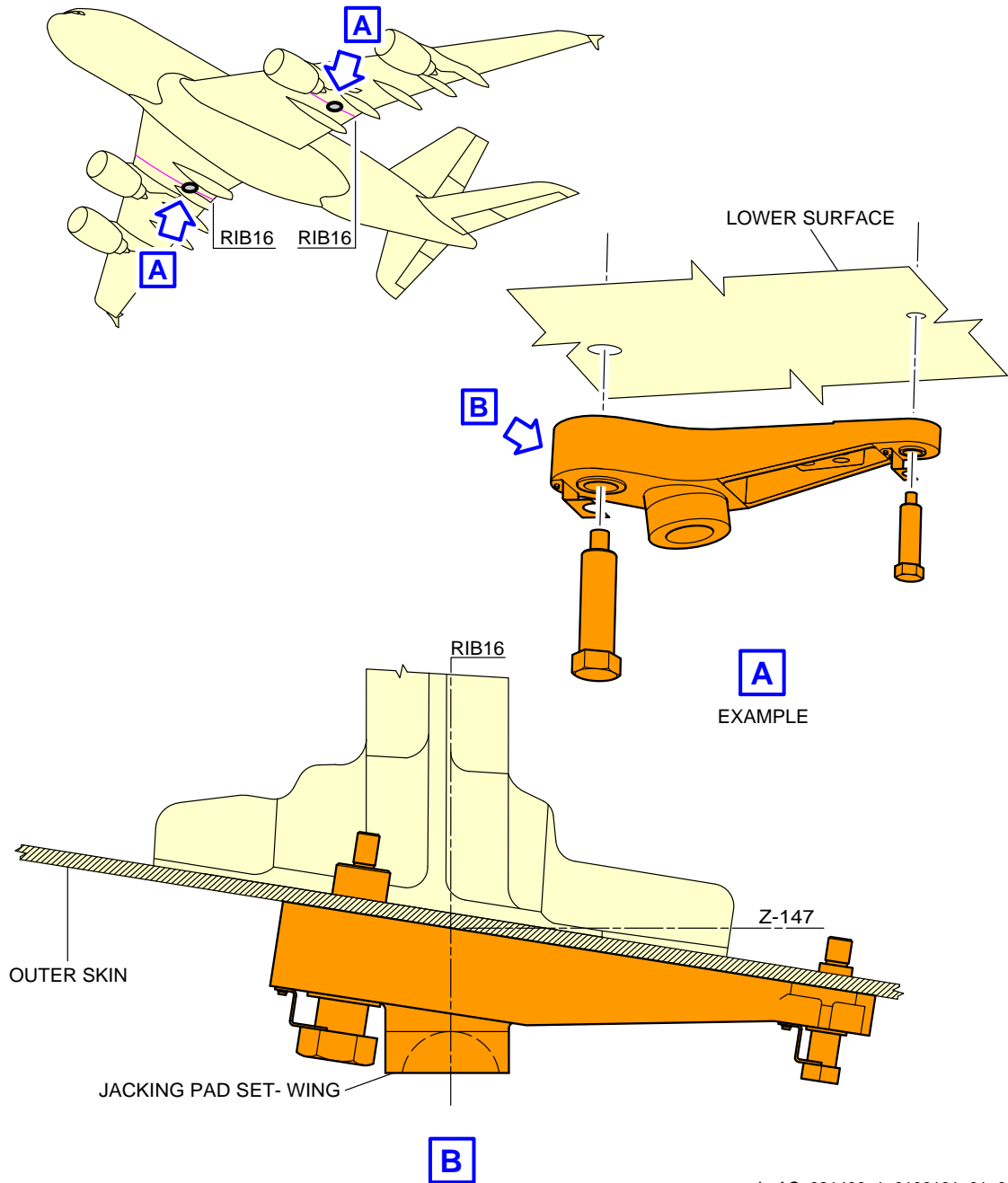

L_AC_021400_1_0100101_01_00

Jacking for Maintenance
Wing Jacking Point
FIGURE-2-14-0-991-010-A01

****ON A/C A380-800**

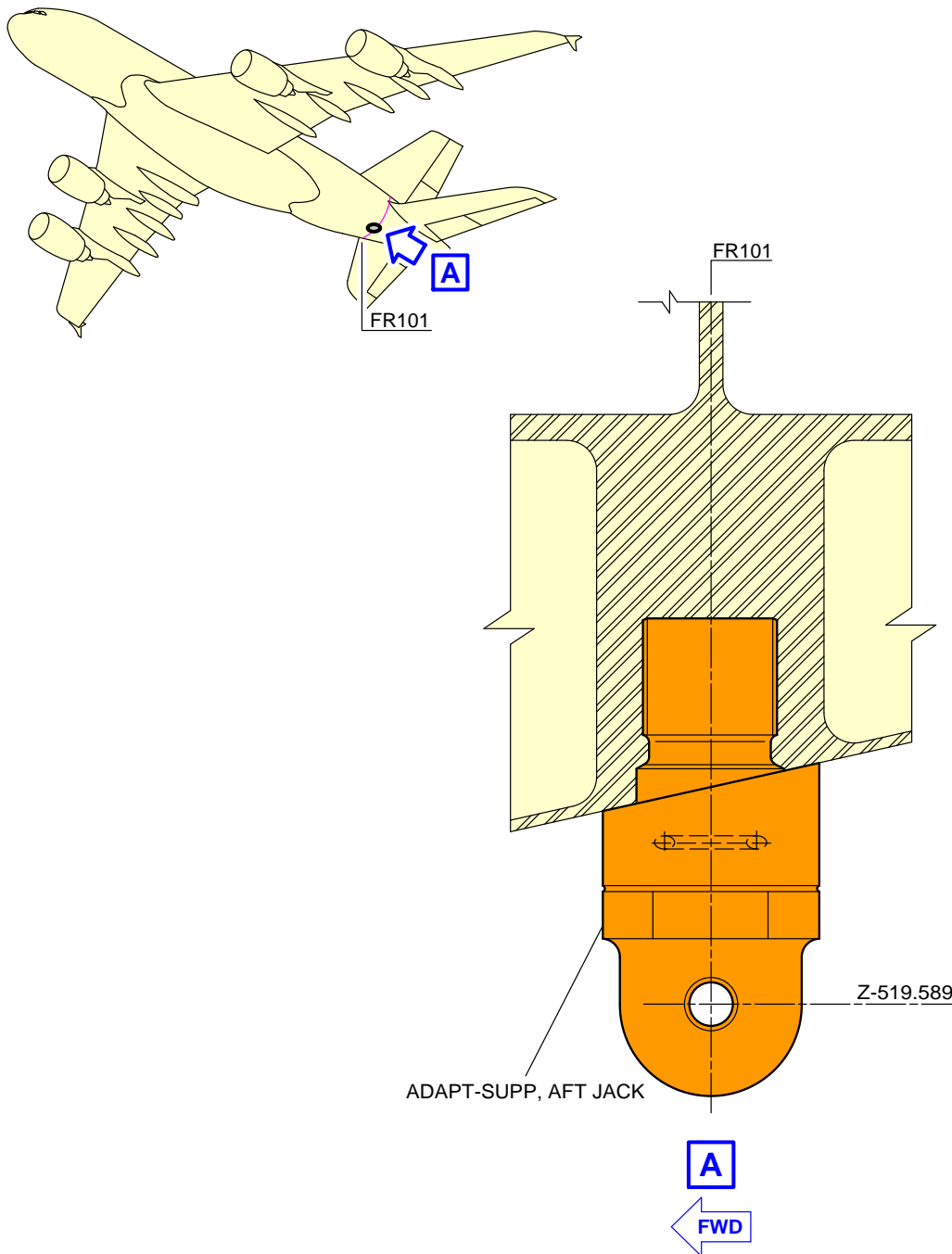

L_AC_021400_1_0110101_01_00

Jacking for Maintenance
Auxiliary Jacking Point - Safety Stay
FIGURE-2-14-0-991-011-A01

****ON A/C A380-800**Jacking of the Landing Gear

1. To replace a wheel or wheel brake assembly on any of the landing gears it is necessary to lift the landing gear with a jack. The landing gear can be lifted by a pillar jack or with a cantilever jack.

NOTE : You can lift the aircraft at Maximum Ramp Weight (MRW).

NOTE : The load at each jacking position is the load required to give a 25.5 mm (1 in) clearance between the ground and the tire.

A. Nose Landing Gear (NLG)

The nose gear can be lifted with a pillar jack or a cantilever jack. The NLG has a dome shaped jacking adaptor at the base of the shock absorber strut. The adapter is 31.75 mm (1.25 in) in diameter.

Important dimensions of the NLG when lifted are shown in FIGURE 2-14-0-991-004-A.

NOTE : The maximum load at NLG jacking point is 42 000 daN (94 420 lbf).

B. Wing Landing Gear (WLG)

An adapter at the front and rear of each bogie is fitted to make sure that the jack is located correctly. The adapter is 31.75 mm (1.25 in) in diameter. The wheels and brake units can be replaced on the end of the bogie beam that is lifted.

The FWD and AFT ends of the bogie can be lifted at the same time. When lifting both ends at the same time the bogie beam must always be kept level to prevent damage.

If a WLG has all four tires deflated or shredded, replace the wheel assemblies in this sequence:

- Replace the wheel assemblies on the AFT axle,
- Replace the wheel assemblies on the FWD axle.

Important dimensions of the WLG when lifted are shown in FIGURE 2-14-0-991-005-A.

NOTE : The maximum load at each WLG jacking point is 80 000 daN (179 847 lbf).

C. Body Landing Gear (BLG)

An adapter at the front and at the rear of each bogie is fitted to make sure that the jack is located correctly. The adapter is 31.75 mm (1.25 in) in diameter. Both wheels and brake units can be replaced on the end of the bogie beam that is lifted.

For a center wheel change only, the FWD and AFT ends of the bogie can be lifted at the same time. When lifting both ends at the same time the bogie beam must always be kept level to prevent damage.

If a BLG has all six tires deflated or shredded, replace the wheel assemblies in this sequence:

- Replace the wheel assemblies on the AFT axle,
- Replace the wheel assemblies on the center axle,
- Replace the wheel assemblies on the FWD axle.

Important dimensions of the BLG when lifted are shown in FIGURE 2-14-0-991-006-A.

NOTE : The maximum load at BLG jacking point is 136 000 daN (305 740 lbf).

****ON A/C A380-800**

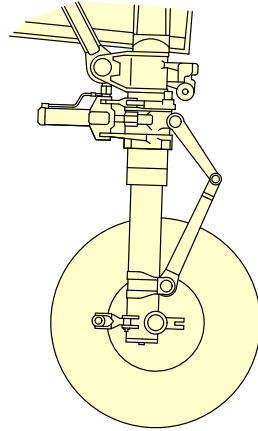

VIEW LOOKING INBOARD LHS
(LH WHEEL NOT SHOWN)

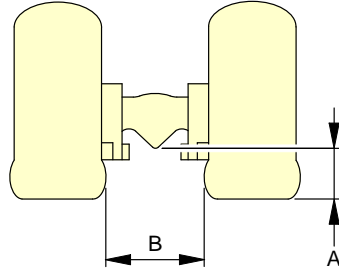

DATA FOR 1 270 x 455 R22 TIRES

CONFIGURATION	WEIGHT	CG%	DIM. A	DIM. B
2 INFLATED TIRES	MRW	43	400 (15.75)	541 (21.3)
1 INFLATED TIRE	MRW	43	353 (13.9)	530 (20.87)
2 DEFLATED TIRES +50% RIM DAMAGE	MLW -PAX	29	134 (5.28)	519 (20.43)
2 DEFLATED TIRES +50% RIM DAMAGE	MLW -PAX	44	136 (5.35)	519 (20.43)
2 DEFLATED TIRES NO RIM DAMAGE	MLW -PAX	29	164 (6.46)	519 (20.43)
2 DEFLATED TIRES NO RIM DAMAGE	MLW -PAX	44	166 (6.54)	519 (20.43)
20 DEFLATED TIRES +50% RIM DAMAGE	N/A	N/A	137 (5.39)	519 (20.43)
20 DEFLATED TIRES NO RIM DAMAGE	N/A	N/A	168 (6.61)	519 (20.43)
MAXIMUM JACKING HEIGHT TO CHANGE WHEELS	N/A	N/A	506 (19.92)	N/A

NOTE: DIMENSIONS IN MILLIMETERS (INCHES IN BRACKETS)

MRW = 562 000 kg (1 238 998 lb)

MLW = 386 000 kg (850 984 lb)

L_AC_021400_1_0040101_01_00

Nose Landing Gear Jacking Point Heights
FIGURE-2-14-0-991-004-A01

****ON A/C A380-800**

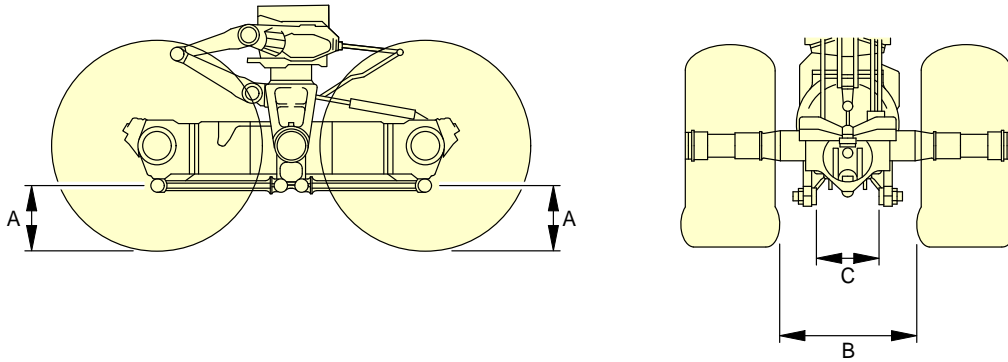

DATA FOR 1 400 x 530 R23 TIRES

CONFIGURATION	WEIGHT	CG%	DIM. A FWD	DIM. A AFT	DIM. B	DIM. C
ALL 4 TIRES SERVICEABLE	MRW	43	347 (13.66)	347 (13.66)	750 (29.53)	364 (14.33)
1 FWD TIRE DEFLATED	MRW	43	264 (10.39)	353 (13.9)	718 (28.27)	364 (14.33)
1 AFT TIRE DEFLATED	MRW	43	353 (13.9)	264 (10.39)	718 (28.27)	364 (14.33)
2 DEFLATED FWD TIRES +50% RIM DAMAGE	MLW -PAX	44	93 (3.66)	406 (15.98)	686 (27.01)	364 (14.33)
2 DEFLATED AFT TIRES +50% RIM DAMAGE	MLW -PAX	44	406 (15.98)	93 (3.66)	686 (27.01)	364 (14.33)
4 TIRES DEFLATED +50% RIM DAMAGE	MLW -PAX	44	93 (3.66)	93 (3.66)	686 (27.01)	364 (14.33)
FWD TIRE CHANGE MAX. GROWN TIRE	MRW	43	513 (20.2)	331 (13.03)	795 (31.3)	364 (14.33)
AFT TIRE CHANGE MAX. GROWN TIRE	MRW	43	331 (13.03)	513 (20.2)	795 (31.3)	364 (14.33)
20 FLAT TIRES +50% RIM DAMAGE	N/A	N/A	83 (3.27)	83 (3.27)	686 (27.01)	364 (14.33)

NOTE: DIMENSIONS IN MILLIMETERS (INCHES IN BRACKETS)

MRW = 562 000 kg (1 238 998 lb)

MLW = 386 000 kg (850 984 lb)

L_AC_021400_1_0050101_01_00

Wing Landing Gear Jacking Point Heights
FIGURE-2-14-0-991-005-A01

****ON A/C A380-800**

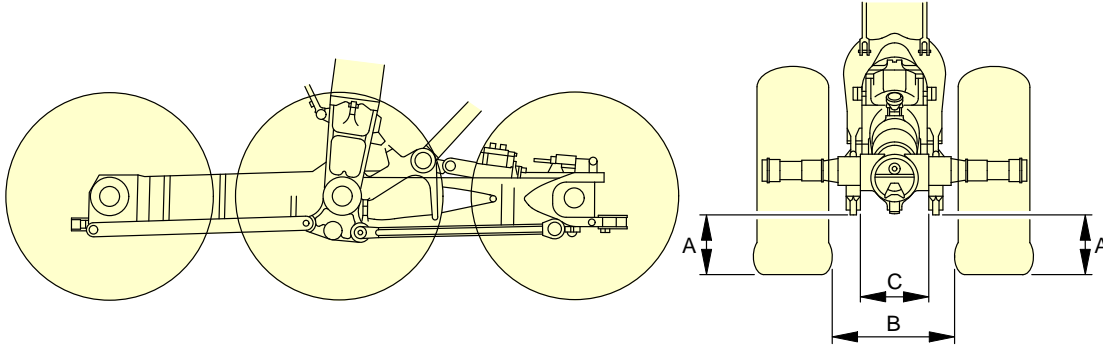

DATA FOR 1 400 x 530 R23 TIRES

CONFIGURATION	WEIGHT	CG%	DIM. A FWD	DIM. A AFT	DIM. B	DIM. C FWD	DIM. C AFT
ALL 6 TIRES SERVICEABLE	MRW	43	347 (13.66)	312 (12.28)	930 (36.61)	460 (18.11)	432 (17.01)
1 FWD TIRE UNSERVICEABLE	MRW	43	295 (11.61)	328 (12.91)	898 (35.35)	460 (18.11)	432 (17.01)
1 CENTER TIRE UNSERVICEABLE	MRW	43	334 (13.15)	299 (11.77)	898 (35.35)	460 (18.11)	432 (17.01)
1 AFT TIRE UNSERVICEABLE	MRW	43	363 (14.29)	260 (10.24)	898 (35.35)	460 (18.11)	432 (17.01)
2 FWD TIRES DEFLATED +50% RIM DAMAGE	MLW -PAX	44	74 (2.91)	505 (19.88)	866 (34.09)	460 (18.11)	432 (17.01)
2 CENTER TIRES DEFLATED	MLW -PAX	44	358 (14.09)	323 (12.72)	866 (34.09)	460 (18.11)	432 (17.01)
2 AFT TIRES DEFLATED +50% RIM DAMAGE	MLW -PAX	44	540 (21.26)	40 (1.57)	866 (34.09)	460 (18.11)	432 (17.01)
6 TIRES DEFLATED +50% RIM DAMAGE	MLW -PAX	44	74 (2.91)	39 (1.54)	866 (34.09)	460 (18.11)	432 (17.01)
FWD TIRE CHANGE MAX. GROWN TIRE	MRW	43	496 (19.53)	264 (10.39)	975 (38.39)	460 (18.11)	432 (17.01)
CTR TIRE CHANGE POSITION MAX. GROWN TIRE	MRW	43	496 (19.53)	461 (18.15)	975 (38.39)	460 (18.11)	432 (17.01)
AFT TIRE CHANGE MAX. GROWN TIRE	MRW	43	299 (11.77)	461 (18.15)	975 (38.39)	460 (18.11)	432 (17.01)
20 DEFLATED TIRES +50% RIM DAMAGE	N/A	N/A	102 (4.02)	67 (2.64)	866 (34.09)	460 (18.11)	432 (17.01)

NOTE: DIMENSIONS IN MILLIMETERS (INCHES IN BRACKETS)

MRW = 562 000 kg (1 238 998 lb)

MLW = 386 000 kg (850 984 lb)

L_AC_021400_1_0060101_01_00

Body Landing Gear Jacking Point Heights
FIGURE-2-14-0-991-006-A01

AIRCRAFT PERFORMANCE**3-1-0 General Information******ON A/C A380-800**General Information

1. Standard day temperatures for the altitudes shown are tabulated below :

Standard day temperatures for the altitudes			
Altitude		Standard Day Temperature	
FEET	METERS	°F	°C
0	0	59.0	15.0
2000	610	51.9	11.6
4000	1220	44.7	7.1
6000	1830	37.6	3.1
8000	2440	30.5	-0.8



3-2-1 Payload/Range - ISA Conditions

****ON A/C A380-800**

Payload/Range - ISA Conditions

1. This section provides the payload/range at ISA conditions.

**ON A/C A380-800

NOTE: THESE CURVES ARE GIVEN FOR INFORMATION ONLY.
THE APPROVED VALUES ARE STATED IN THE "OPERATING MANUALS"
SPECIFIC TO THE AIRLINE OPERATING THE AIRCRAFT.

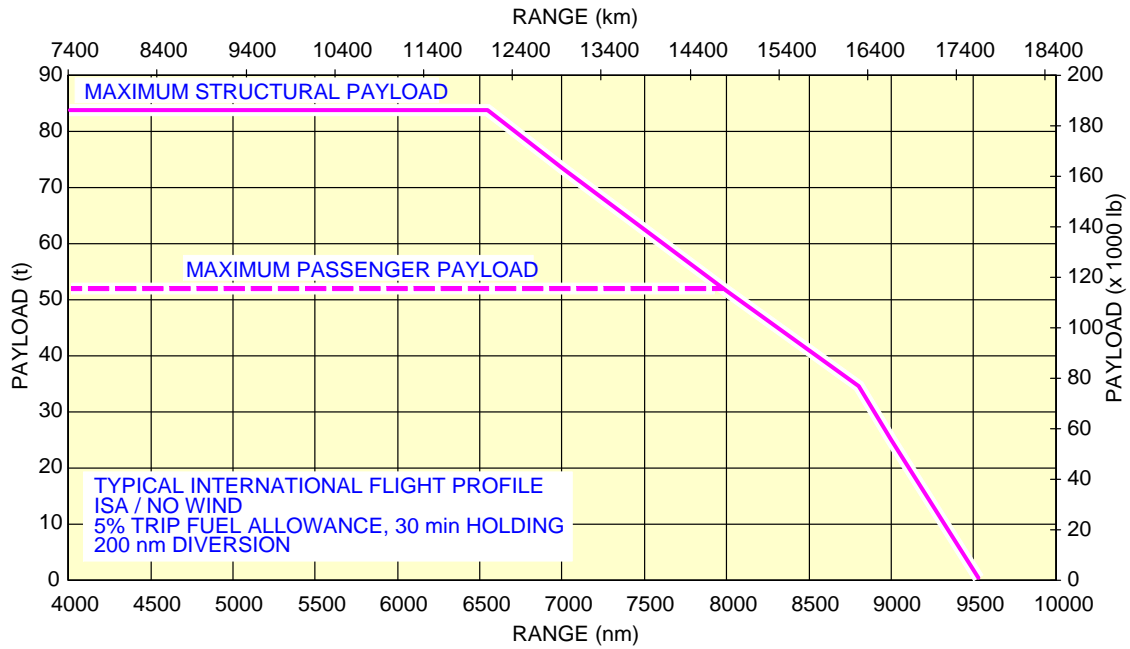

L_AC_030201_1_0010101_01_00

Payload/Range
ISA Conditions - TRENT 900 Engines
FIGURE-3-2-1-991-001-A01

**ON A/C A380-800

NOTE: THESE CURVES ARE GIVEN FOR INFORMATION ONLY.
THE APPROVED VALUES ARE STATED IN THE "OPERATING MANUALS"
SPECIFIC TO THE AIRLINE OPERATING THE AIRCRAFT.

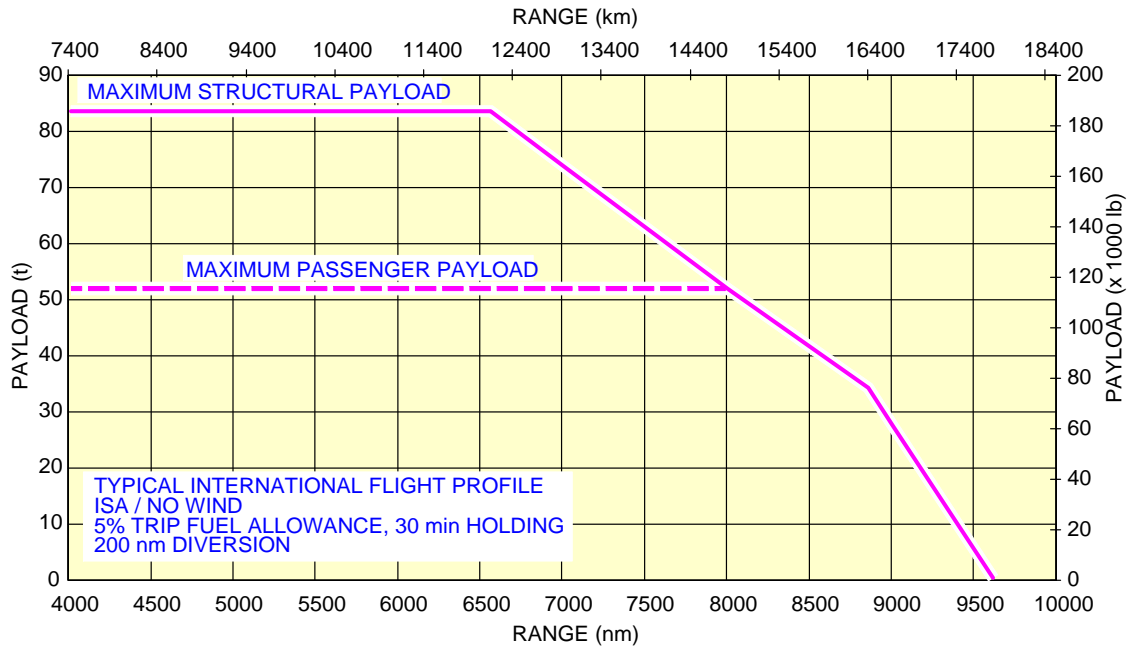

L_AC_030201_1_0080101_01_00

Payload/Range
ISA Conditions - GP 7200 Engines
FIGURE-3-2-1-991-008-A01

3-3-1 Take Off Weight Limitation - ISA Conditions

****ON A/C A380-800**

Take-Off Weight Limitation - ISA Conditions

1. This section provides the take-off weight limitation at ISA conditions.

**ON A/C A380-800

NOTE: THESE CURVES ARE GIVEN FOR INFORMATION ONLY.
THE APPROVED VALUES ARE STATED IN THE "OPERATING MANUALS"
SPECIFIC TO THE AIRLINE OPERATING THE AIRCRAFT.

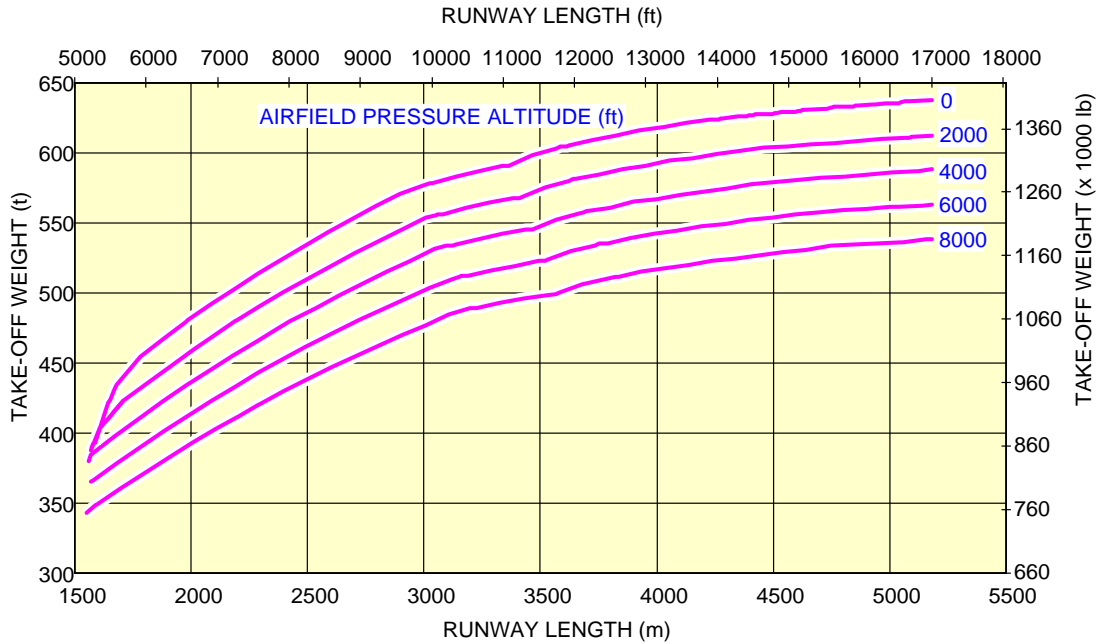

L_AC_030301_1_0010101_01_00

Take-Off Weight Limitation
ISA Conditions - TRENT 900 Engines
FIGURE-3-3-1-991-001-A01

**ON A/C A380-800

NOTE: THESE CURVES ARE GIVEN FOR INFORMATION ONLY.
THE APPROVED VALUES ARE STATED IN THE "OPERATING MANUALS"
SPECIFIC TO THE AIRLINE OPERATING THE AIRCRAFT.

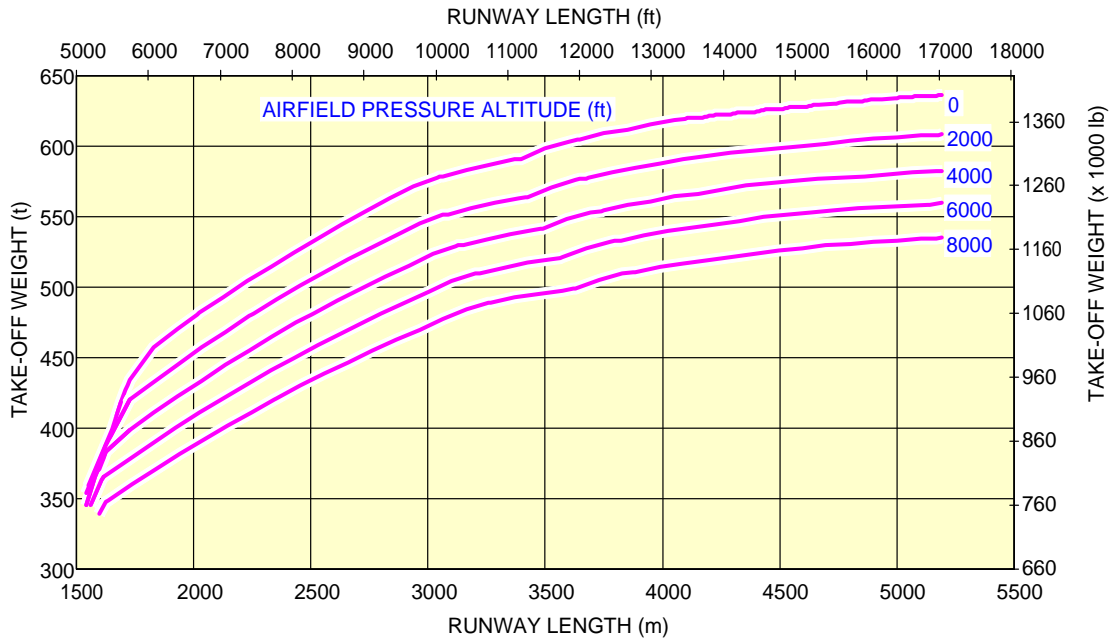

L_AC_030301_1_0080101_01_00

Take-Off Weight Limitation
ISA Conditions - GP 7200 Engines
FIGURE-3-3-1-991-008-A01



3-3-2 Take Off Weight Limitation - ISA + 15 °C (27 °F) Conditions

****ON A/C A380-800**

Take-Off Weight Limitation - ISA + 15 °C (+27 °F) Conditions

1. This section provides the take-off weight limitation at ISA + 15 °C (+27 °F) conditions.

**ON A/C A380-800

NOTE: THESE CURVES ARE GIVEN FOR INFORMATION ONLY.
THE APPROVED VALUES ARE STATED IN THE "OPERATING MANUALS"
SPECIFIC TO THE AIRLINE OPERATING THE AIRCRAFT.

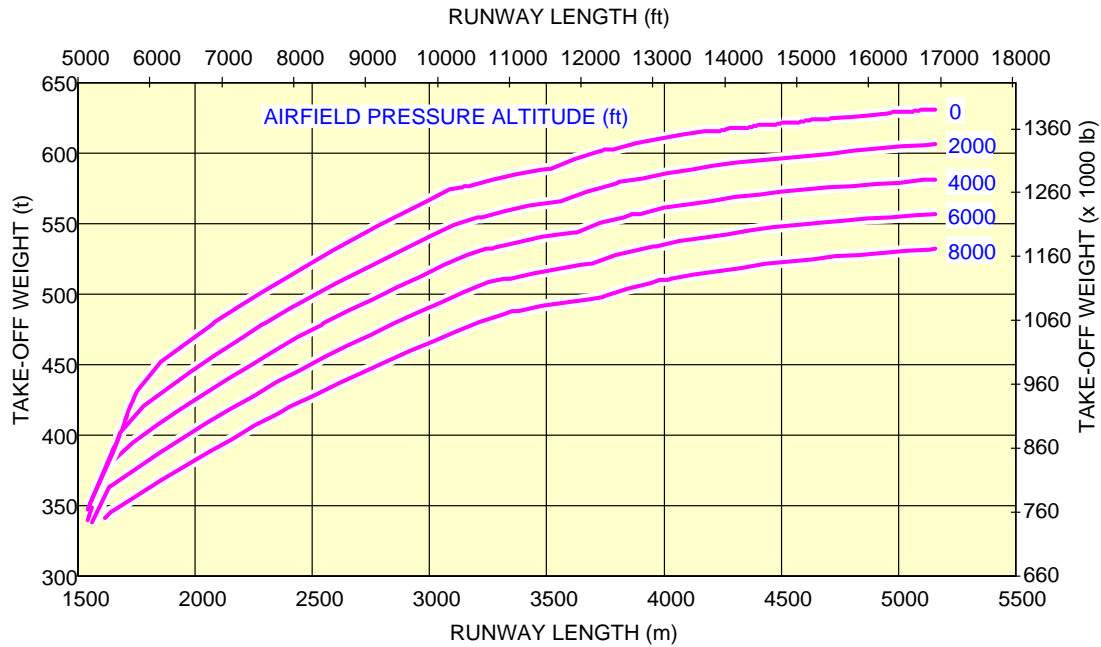

L_AC_030302_1_0010101_01_00

Take-Off Weight Limitation
ISA + 15 °C (+27 °F) Conditions - TRENT 900 Engines
FIGURE-3-3-2-991-001-A01

**ON A/C A380-800

NOTE: THESE CURVES ARE GIVEN FOR INFORMATION ONLY.
THE APPROVED VALUES ARE STATED IN THE "OPERATING MANUALS"
SPECIFIC TO THE AIRLINE OPERATING THE AIRCRAFT.

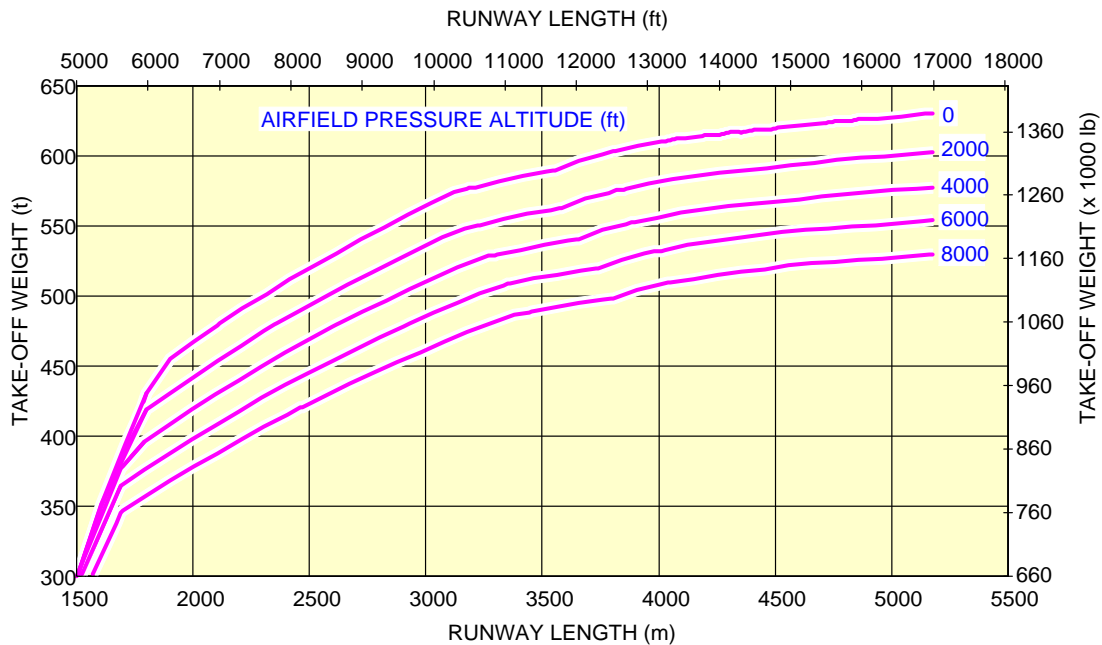

L_AC_030302_1_0080101_01_00

Take-Off Weight Limitation
ISA + 15 °C (+27 °F) Conditions - GP 7200 Engines
FIGURE-3-3-2-991-008-A01



3-3-3 Aerodrome Reference Code

****ON A/C A380-800**

Aerodrome Reference Code

1. A380 can operate on aerodromes classified as code 4F as per ICAO Aerodrome Reference Code. It can also operate on aerodromes classified as code 4E provided that specific conditions are met.

3-4-1 Landing Field Length - ISA Conditions

****ON A/C A380-800**

Landing Field Length

1. This section provides the landing field length on a dry runway.

**ON A/C A380-800

NOTE: THESE CURVES ARE GIVEN FOR INFORMATION ONLY.
THE APPROVED VALUES ARE STATED IN THE "OPERATING MANUALS"
SPECIFIC TO THE AIRLINE OPERATING THE AIRCRAFT.

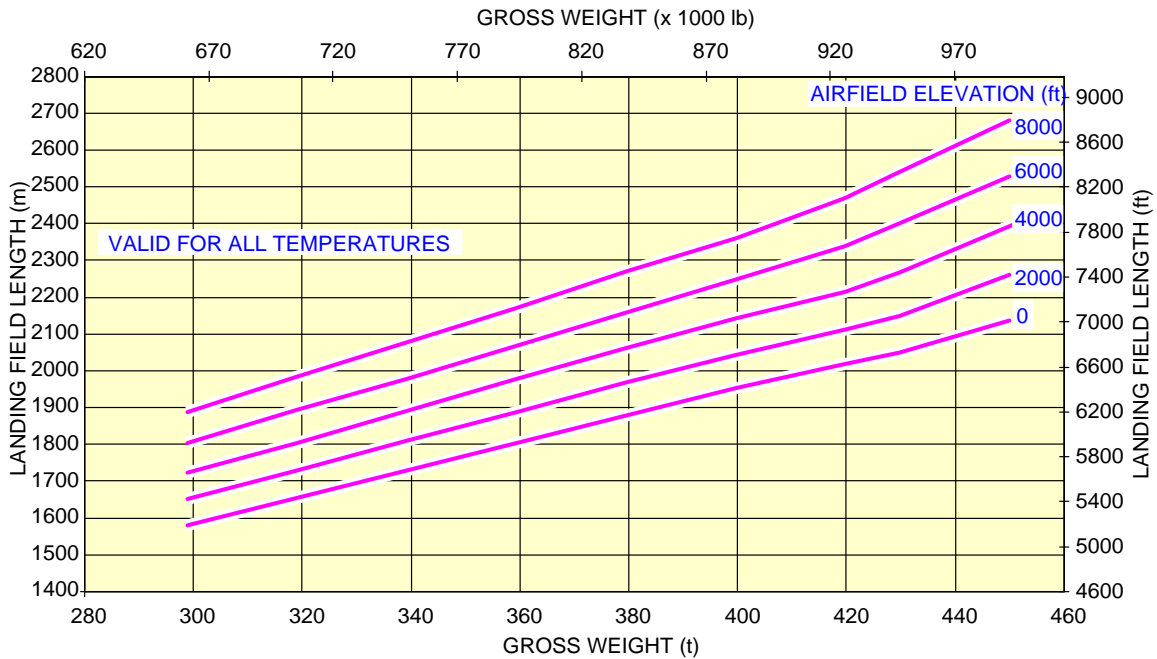

L_AC_030401_1_0010101_01_01

Landing Field Length
Dry Runway
FIGURE-3-4-1-991-001-A01

3-5-0 Final Approach Speed****ON A/C A380-800**Final Approach Speed

1. This section gives the final approach speed which is the indicated airspeed at threshold in the landing configuration at the certificated maximum flap setting and maximum landing weight at standard atmospheric conditions. The approach speed is used to classify the aircraft into Aircraft Approach Category, a grouping of aircraft based on the indicated airspeed at threshold.
2. The final approach speed is 138 kt at a Maximum Landing Weight (MLW) of 395 000 kg (870 826 lb) and classifies the aircraft into the Aircraft Approach Category C.

NOTE : This value is given for information only.

GROUND MANEUVERING**4-1-0 General Information******ON A/C A380-800**General

1. This section provides aircraft turning capability and maneuvering characteristics.

For ease of presentation, this data has been determined from the theoretical limits imposed by the geometry of the aircraft, and where noted, provides for a normal allowance for tire slippage. As such, it reflects the turning capability of the aircraft in favorable operating circumstances. This data should only be used as a guidelines for the method of determination of such parameters and for the maneuvering characteristics of this aircraft type.

In ground operating mode, varying airline practices may demand that more conservative turning procedures be adopted to avoid excessive tire wear and reduce possible maintenance problems. Airline operating techniques will vary in the level of performance, over a wide range of operating circumstances throughout the world. Variations from standard aircraft operating patterns may be necessary to satisfy physical constraints within the maneuvering area, such as adverse grades, limited area or a high risk of jet blast damage. For these reasons, ground maneuvering requirements should be coordinated with the airlines in question prior to layout planning.

4-2-0 Turning Radii

****ON A/C A380-800**

Turning Radii

1. This section provides the turning radii.

****ON A/C A380-800**

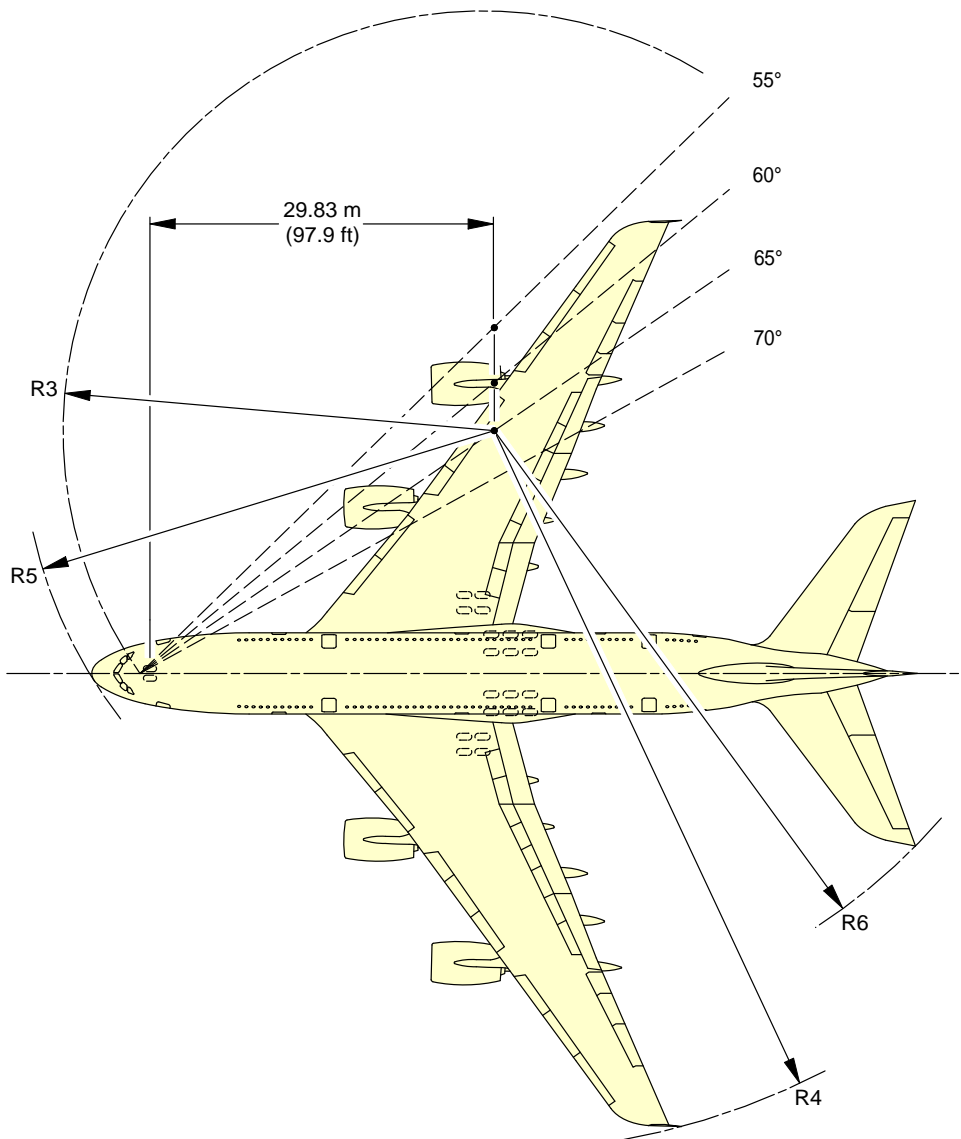

NOTE:
FOR TURNING RADII VALUES, REFER TO SHEET 2.

L_AC_040200_1_0010101_01_01

Turning Radii
(Sheet 1)
FIGURE-4-2-0-991-001-A01

****ON A/C A380-800**

A380-800 TURNING RADII							
TYPE OF TURN	STEERING ANGLE	EFFECTIVE STEERING ANGLE		R3 NLG	R4 WING	R5 NOSE	R6 THS
2	20°	17.9°	m	100.16	135.45	101.01	115.87
			ft	328.6	444.4	331.4	380.1
2	25°	22.7°	m	78.86	113.14	80.12	94.90
			ft	258.7	371.2	262.9	311.4
2	30°	27.5°	m	65.69	98.90	67.33	81.91
			ft	215.5	324.5	220.9	268.7
2	35°	32.1°	m	56.84	88.97	58.83	73.13
			ft	186.5	291.9	193.0	239.9
2	40°	36.6°	m	50.59	81.61	52.89	66.84
			ft	166.0	267.8	173.5	219.3
2	45°	41.0°	m	46.02	75.94	48.61	62.16
			ft	151.0	249.1	159.5	203.9
2	50°	45.1°	m	42.61	71.43	45.45	58.57
			ft	139.8	234.4	149.1	192.2
1	55°	51.2°	m	40.13	67.02	43.22	55.43
			ft	131.6	219.9	141.8	181.9
1	60°	57.3°	m	37.64	62.60	40.98	52.29
			ft	123.5	205.4	134.5	171.5
1	65°	63.4°	m	35.15	58.18	38.75	49.15
			ft	115.3	190.9	127.1	161.2
1	70°	69.5°	m	32.66	53.76	36.52	46.01
			ft	107.2	176.4	119.8	150.9

NOTE:

TYPE 1 TURNS USE :

ASYMMETRIC THRUST - BOTH ENGINES ON THE INSIDE OF THE TURN TO BE AT IDLE THRUST.
DIFFERENTIAL BRAKING - BRAKING APPLIED TO THE WING GEAR WHEELS ON THE INSIDE OF THE TURN.

TYPE 2 TURNS USE :

SYMMETRIC THRUST AND NO BRAKING.

L_AC_040200_1_0020101_01_01

Turning Radii
(Sheet 2)
FIGURE-4-2-0-991-002-A01

4-3-0 Minimum Turning Radii

****ON A/C A380-800**

Minimum Turning Radii

1. This section provides the minimum turning radii.

****ON A/C A380-800**

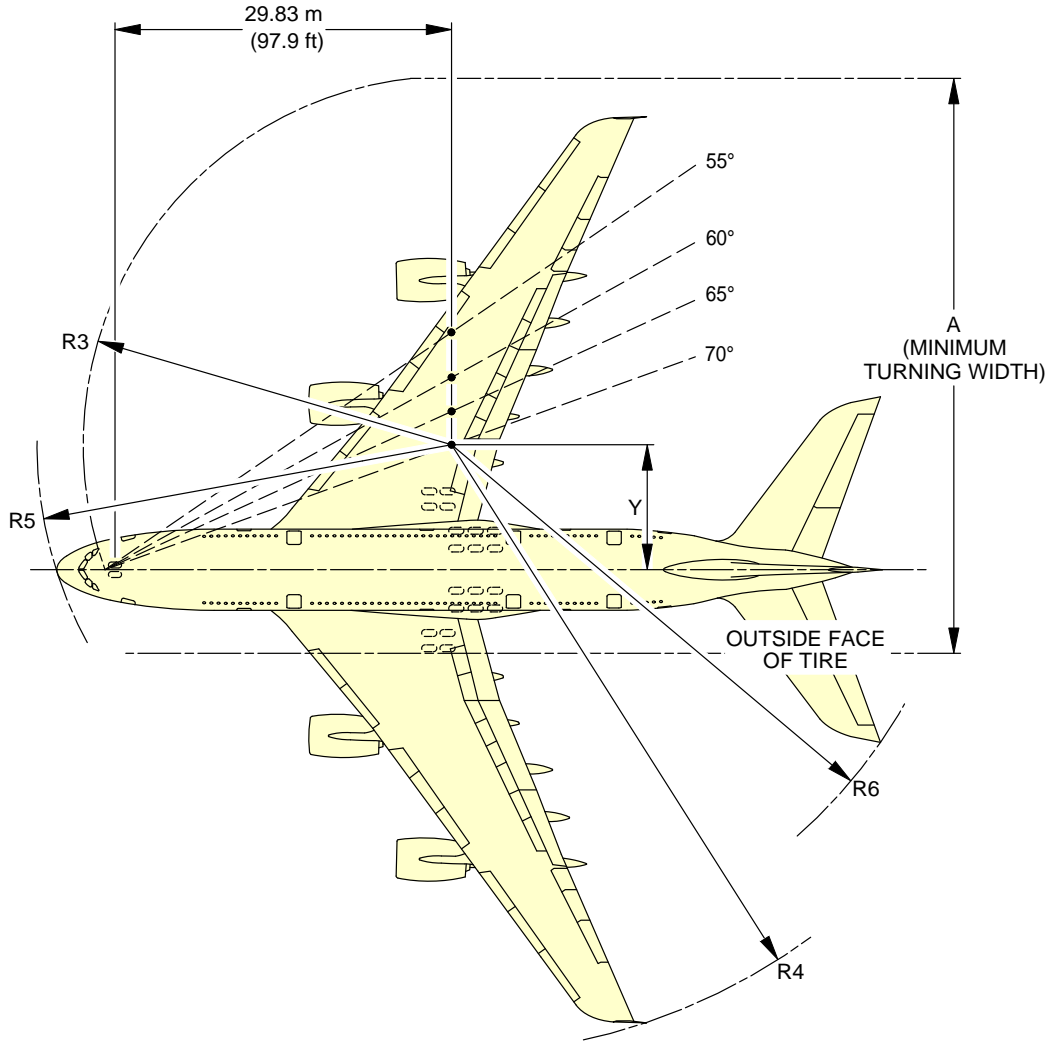

A380-800 MINIMUM TURNING RADIUS									
TYPE OF TURN	STEERING ANGLE	EFFECTIVE STEERING ANGLE		Y	A	R3 NLG	R4 WING	R5 NOSE	R6 THS
1	70°	69.5°	m	11.08	50.91	32.66	53.76	36.52	46.01
			ft	36.3	167.0	107.2	176.4	119.8	150.9

NOTE:

TURN PERFORMED WITH ASYMMETRIC THRUST AND DIFFERENTIAL BRAKING.

L_AC_040300_1_0010101_01_02

Minimum Turning Radii
FIGURE-4-3-0-991-001-A01

4-4-0 Visibility from Cockpit in Static Position****ON A/C A380-800**Visibility from Cockpit in Static Position

1. This section gives the visibility from cockpit in static position.

****ON A/C A380-800**

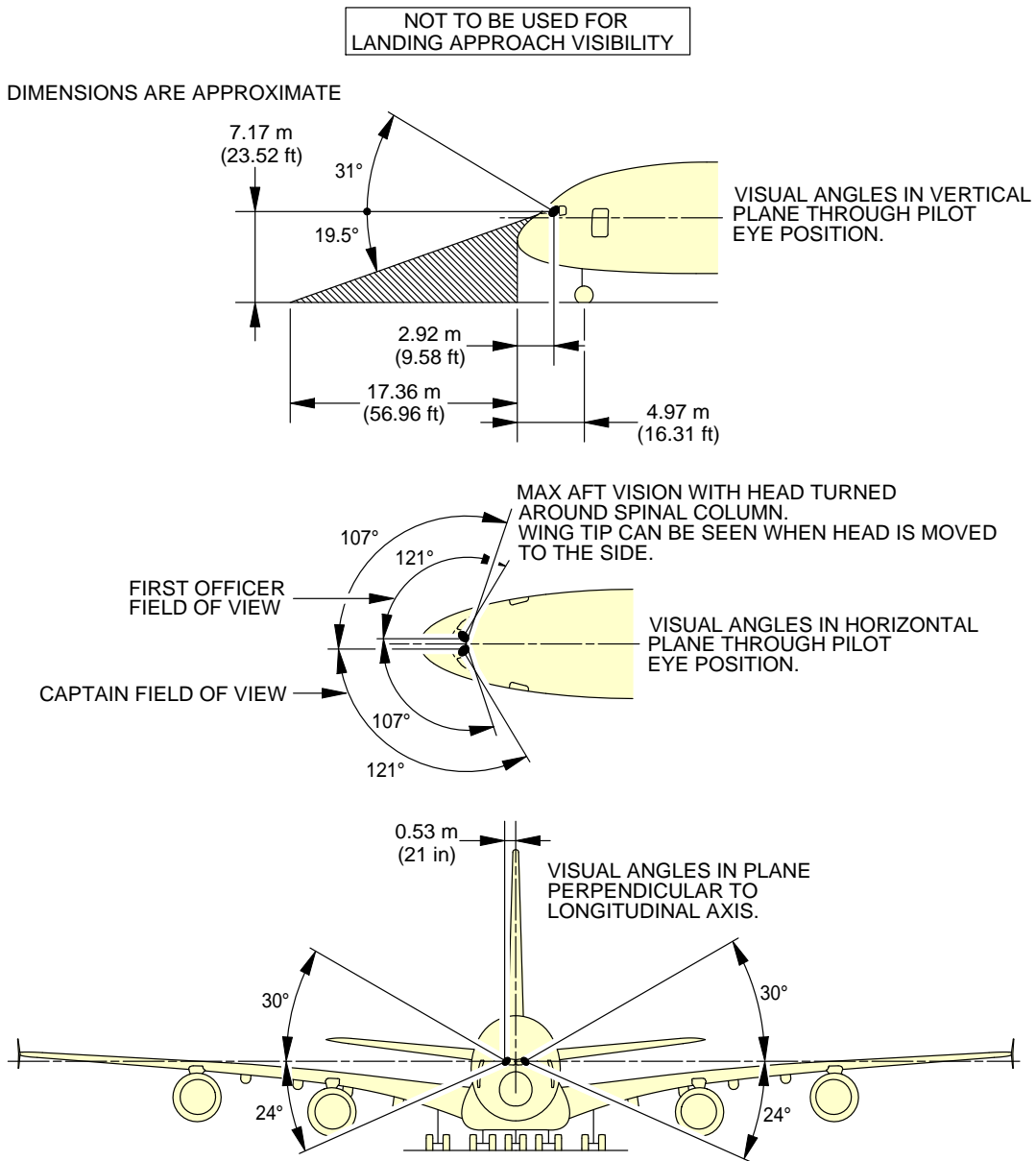

NOTE:

- PILOT EYE POSITION WHEN PILOT'S EYES ARE IN LINE WITH THE RED AND WHITE BALLS.



ZONE THAT CANNOT BE SEEN

L_AC_040400_1_0010101_01_02

Visibility from Cockpit in Static Position
FIGURE-4-4-0-991-001-A01

****ON A/C A380-800**

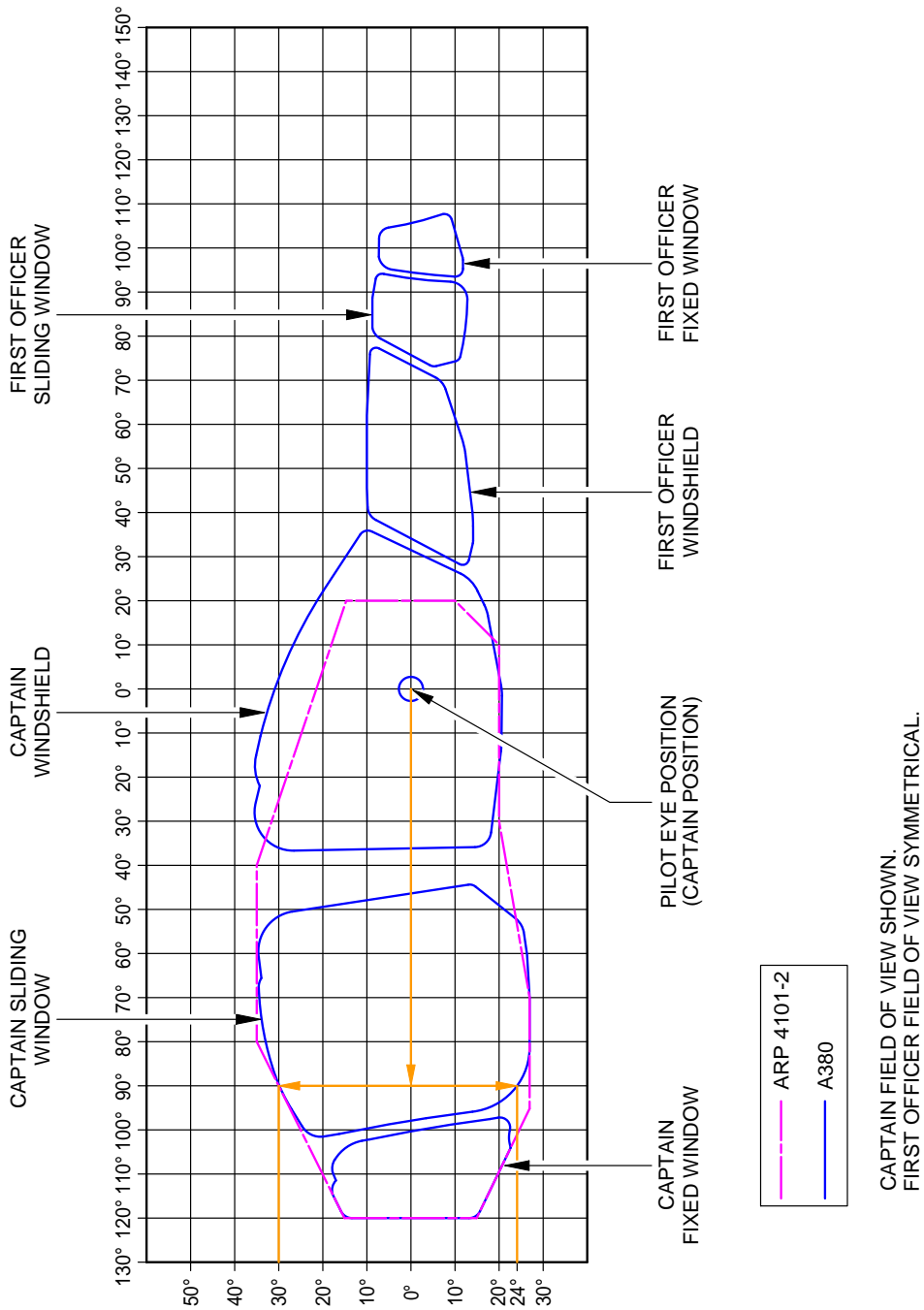

CAPTAIN FIELD OF VIEW SHOWN.
 FIRST OFFICER FIELD OF VIEW SYMMETRICAL.

EXAMPLE: WHEN CAPTAIN TURNS HIS HEAD BY 90° LEFT, VISIBILITY WILL BE 30° UP AND 24° DOWN THROUGH THE SLIDING WINDOW FRAME.

L_AC_040400_1_0020101_01_00

Binocular Visibility Through Windows from Captain Eye Position
 FIGURE-4-4-0-991-002-A01

4-5-0 Runway and Taxiway Turn Paths

****ON A/C A380-800**

Runway and Taxiway Turn Paths

1. Runway and Taxiway Turn Paths

4-5-1 135° Turn - Runway to Taxiway****ON A/C A380-800**135° Turn - Runway to Taxiway

1. This section gives the 135° turn – runway to taxiway.

****ON A/C A380-800**

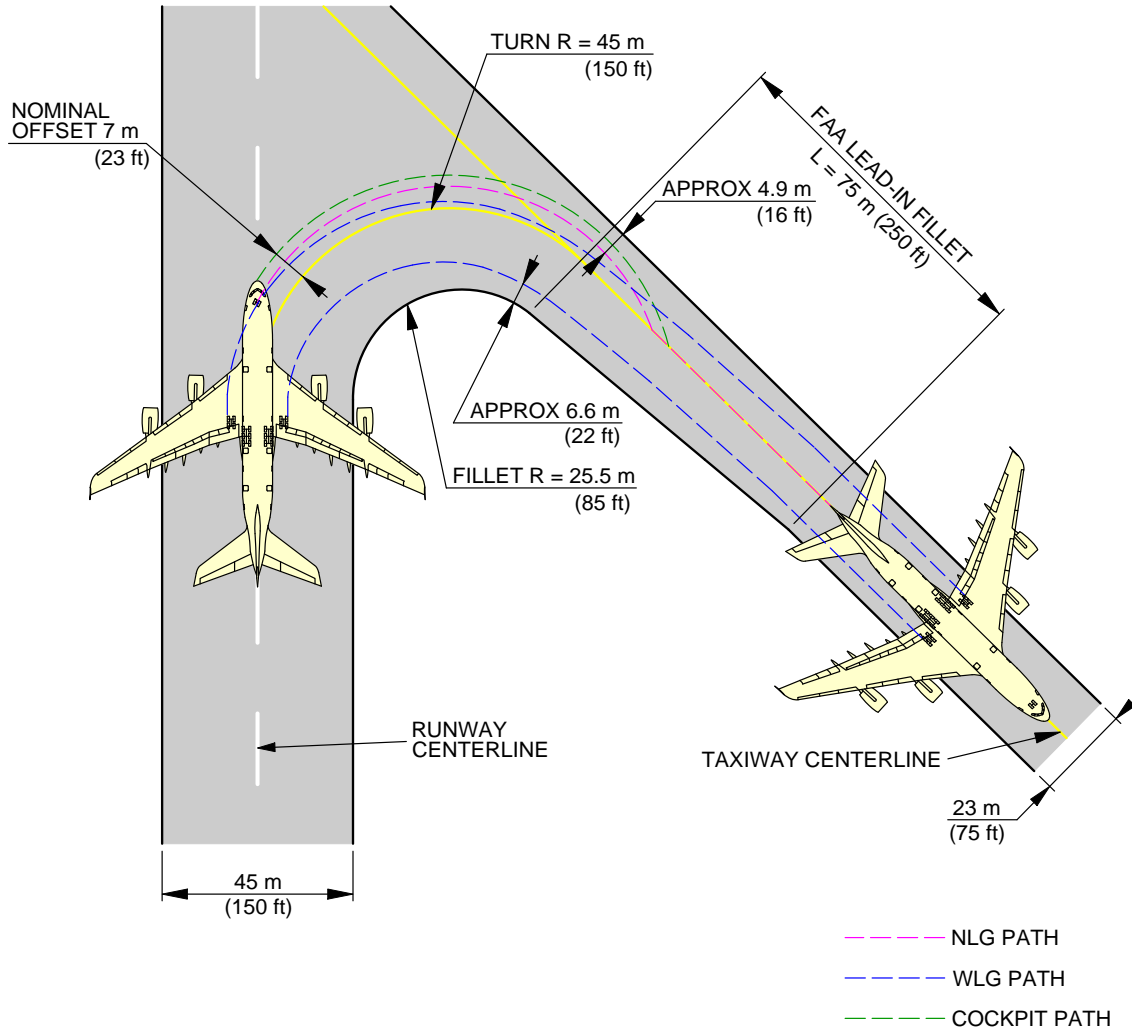

NOTE: FAA GROUP V FACILITIES.

L_AC_040501_1_0010101_01_01

135° Turn – Runway to Taxiway
Judgemental Oversteer Method
FIGURE-4-5-1-991-001-A01

****ON A/C A380-800**

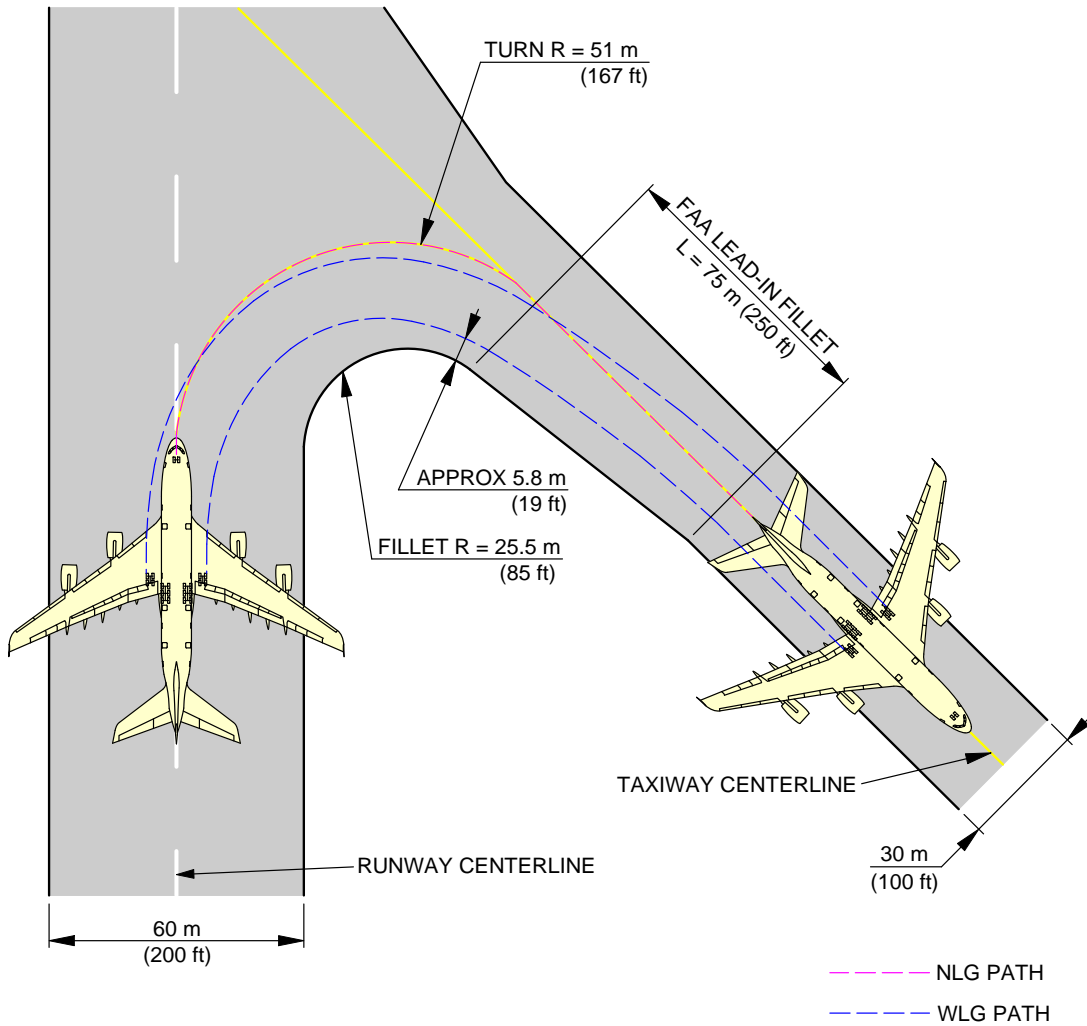

NOTE: FAA GROUP VI FACILITIES.

L_AC_040501_1_0020101_01_01

135° Turn – Runway to Taxiway
Cockpit Tracks Centreline Method
FIGURE-4-5-1-991-002-A01

4-5-2 90° Turn - Runway to Taxiway****ON A/C A380-800**90° Turn - Runway to Taxiway

1. This section gives the 90° turn – runway to taxiway.

****ON A/C A380-800**

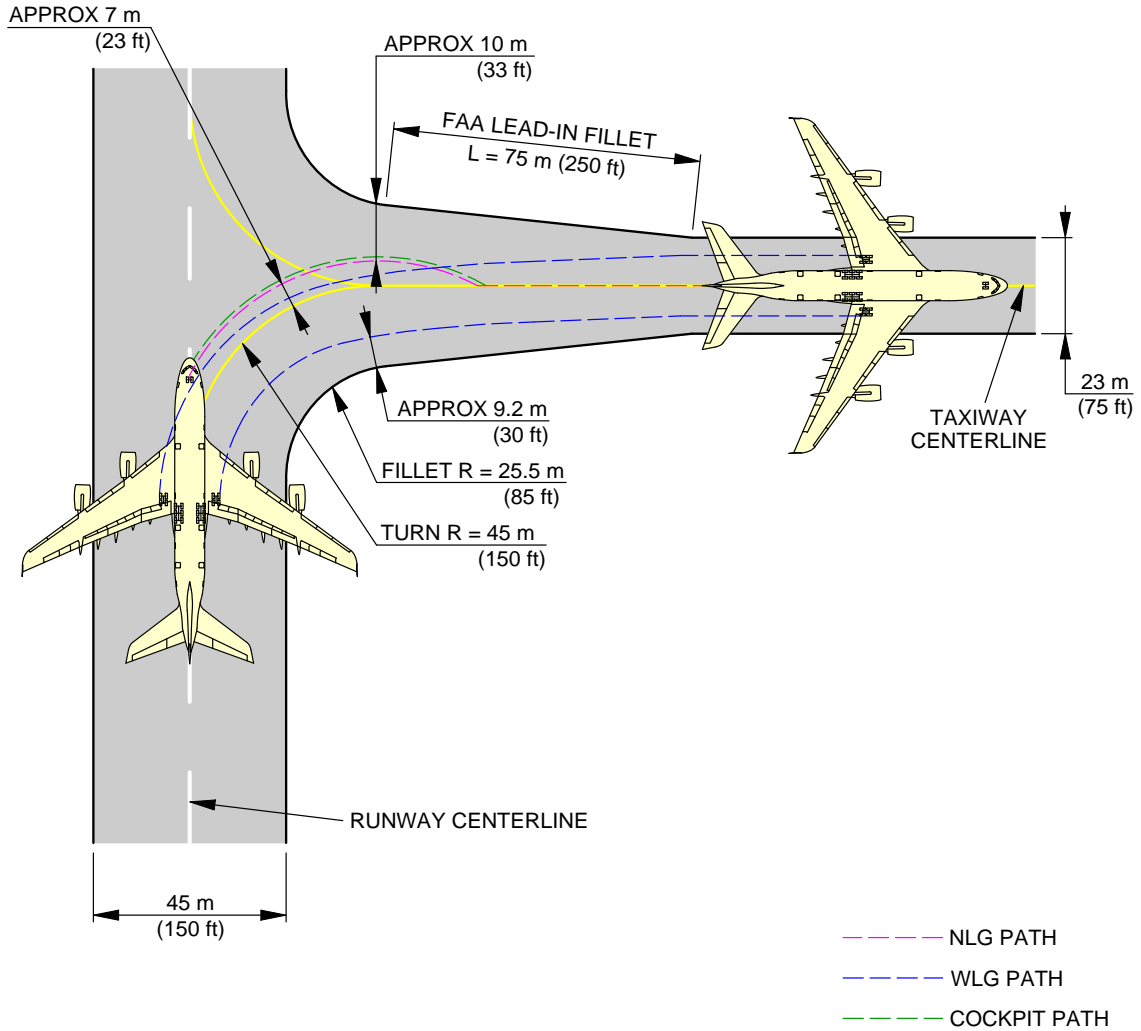

NOTE: FAA GROUP V FACILITIES.

L_AC_040502_1_0010101_01_01

90° Turn – Runway to Taxiway
Judgemental Oversteer Method
FIGURE-4-5-2-991-001-A01

****ON A/C A380-800**

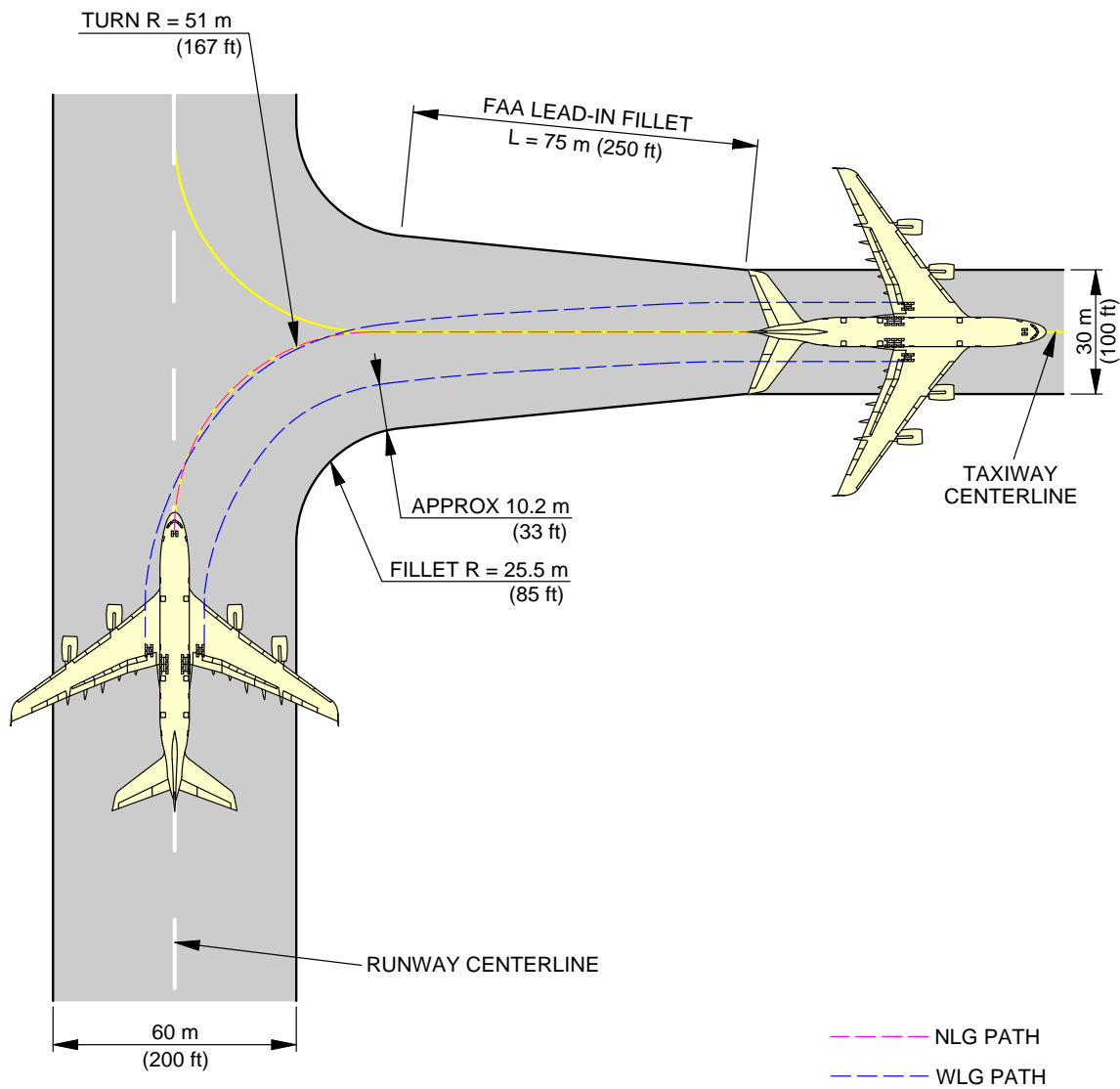

NOTE: FAA GROUP VI FACILITIES.

L_AC_040502_1_0020101_01_01

90° Turn – Runway to Taxiway
Cockpit Tracks Centreline Method
FIGURE-4-5-2-991-002-A01

4-5-3 180° Turn on a Runway****ON A/C A380-800**180° Turn on a Runway

1. This section gives the 180° turn on a runway.

****ON A/C A380-800**

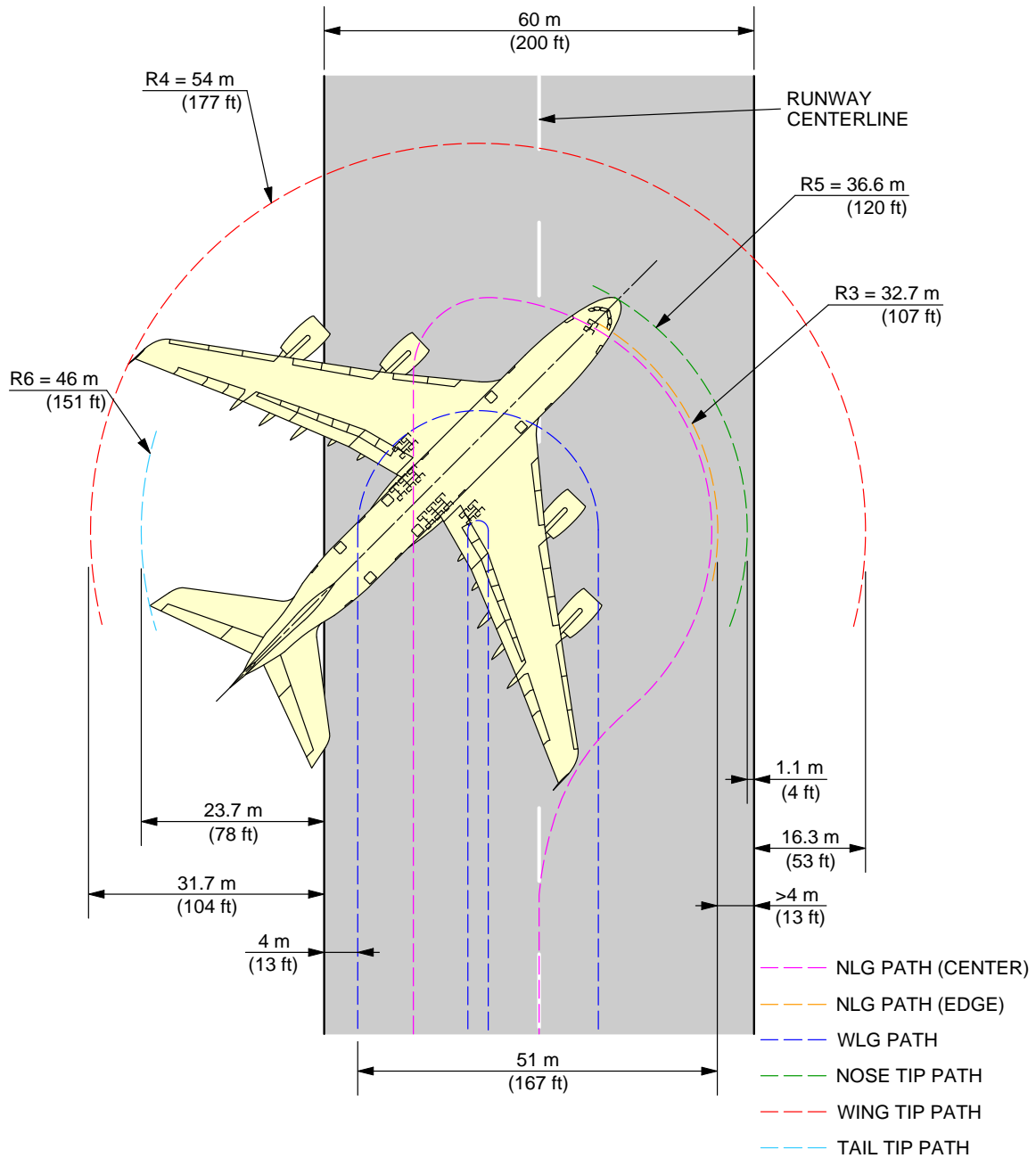

NOTE: 70° NOSE GEAR STEERING - ASYMMETRIC THRUST AND BRAKING ON A 60 m (200 ft) WIDE RUNWAY.

L_AC_040503_1_0010101_01_02

180° Turn on a Runway
FIGURE-4-5-3-991-001-A01

4-5-4 135° Turn - Taxiway to Taxiway****ON A/C A380-800**135° Turn - Taxiway to Taxiway

1. This section gives the 135° turn - taxiway to taxiway.

****ON A/C A380-800**

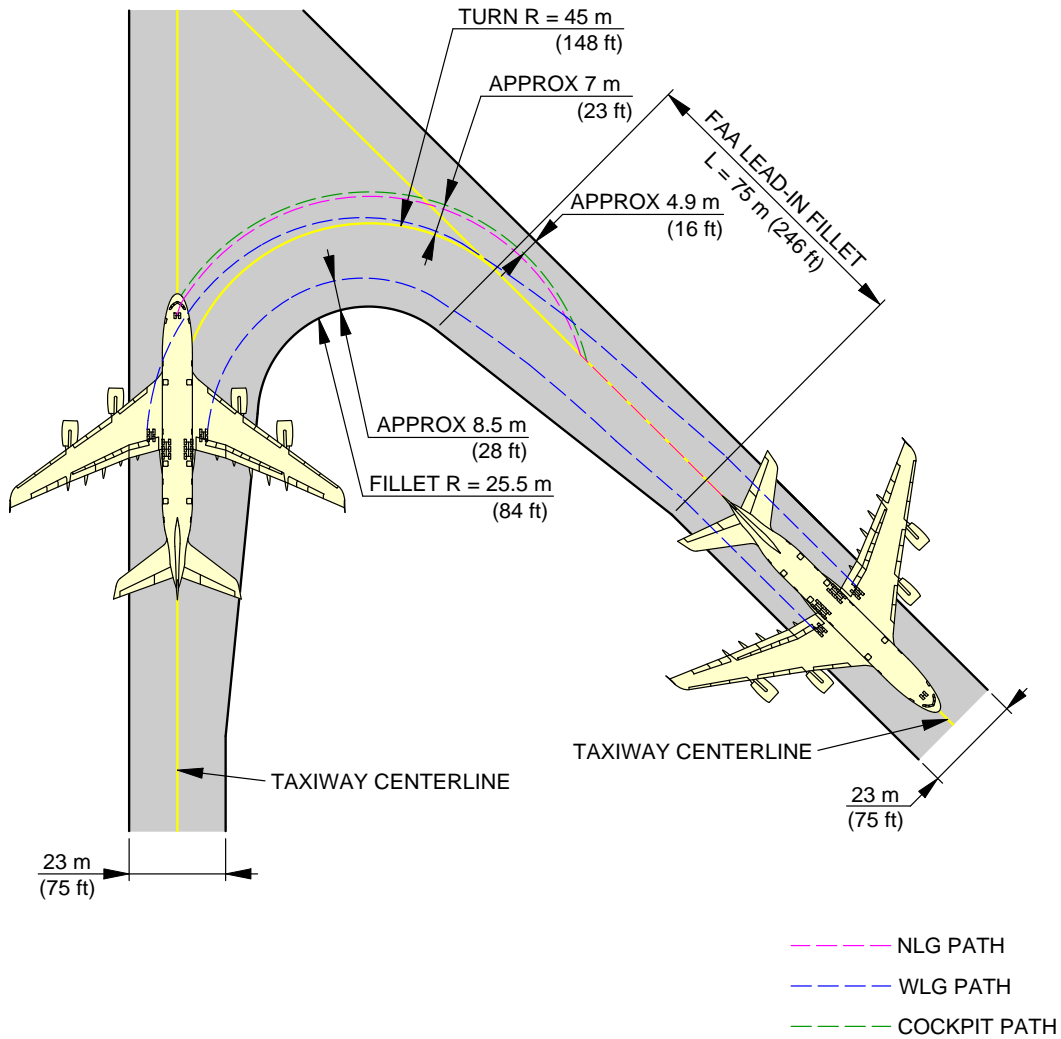

NOTE:
FAA GROUP V FACILITIES.

L_AC_040504_1_0010101_01_02

135° Turn – Taxiway to Taxiway
Judgemental Oversteer Method
FIGURE-4-5-4-991-001-A01

****ON A/C A380-800**

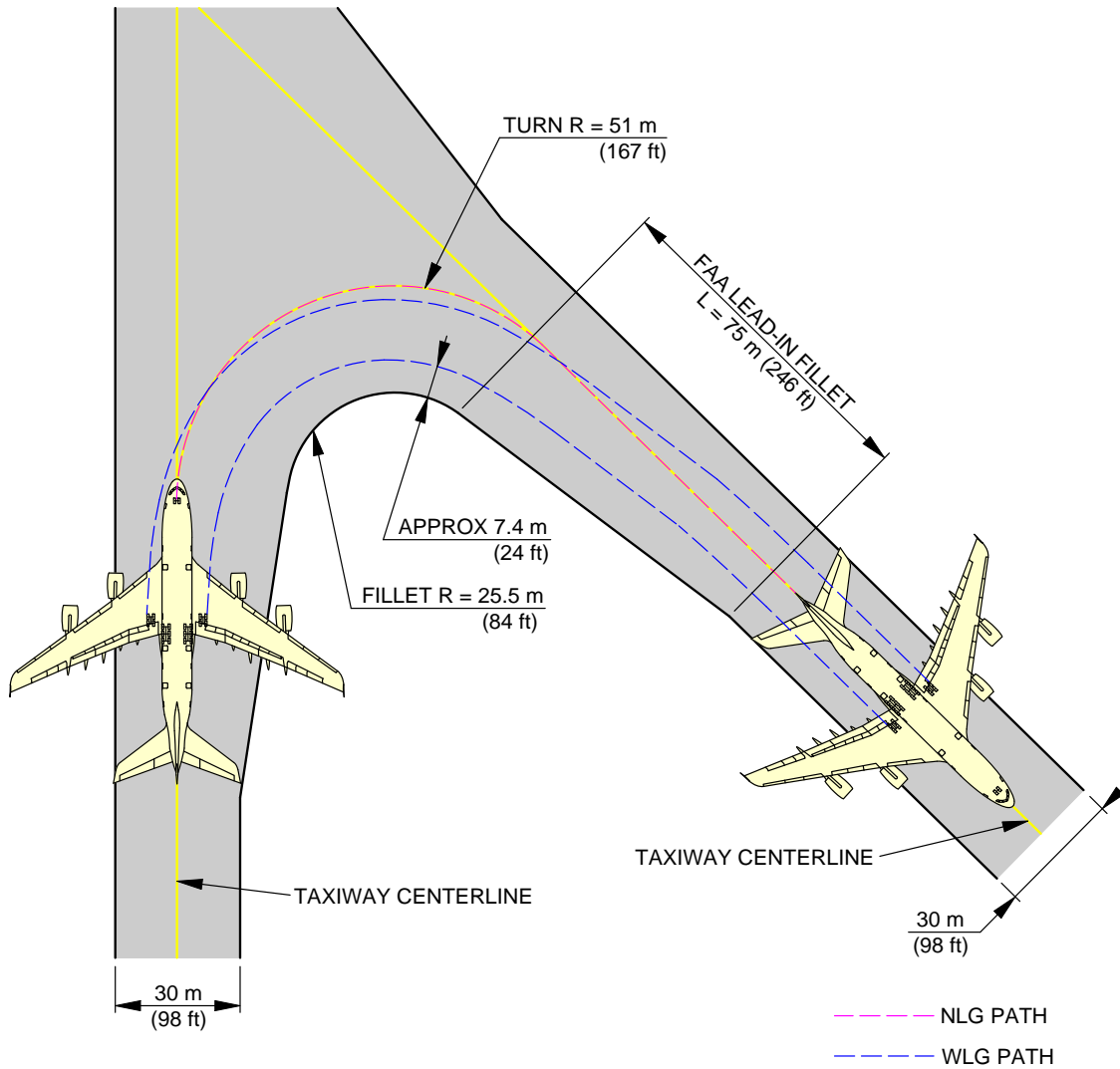

NOTE:
FAA GROUP VI FACILITIES.

L_AC_040504_1_0020101_01_02

135° Turn – Taxiway to Taxiway
Cockpit Tracks Centerline Method
FIGURE-4-5-4-991-002-A01

4-5-5 90° Turn - Taxiway to Taxiway****ON A/C A380-800**90° Turn - Taxiway to Taxiway

1. This section gives the 90° turn - taxiway to taxiway.

****ON A/C A380-800**

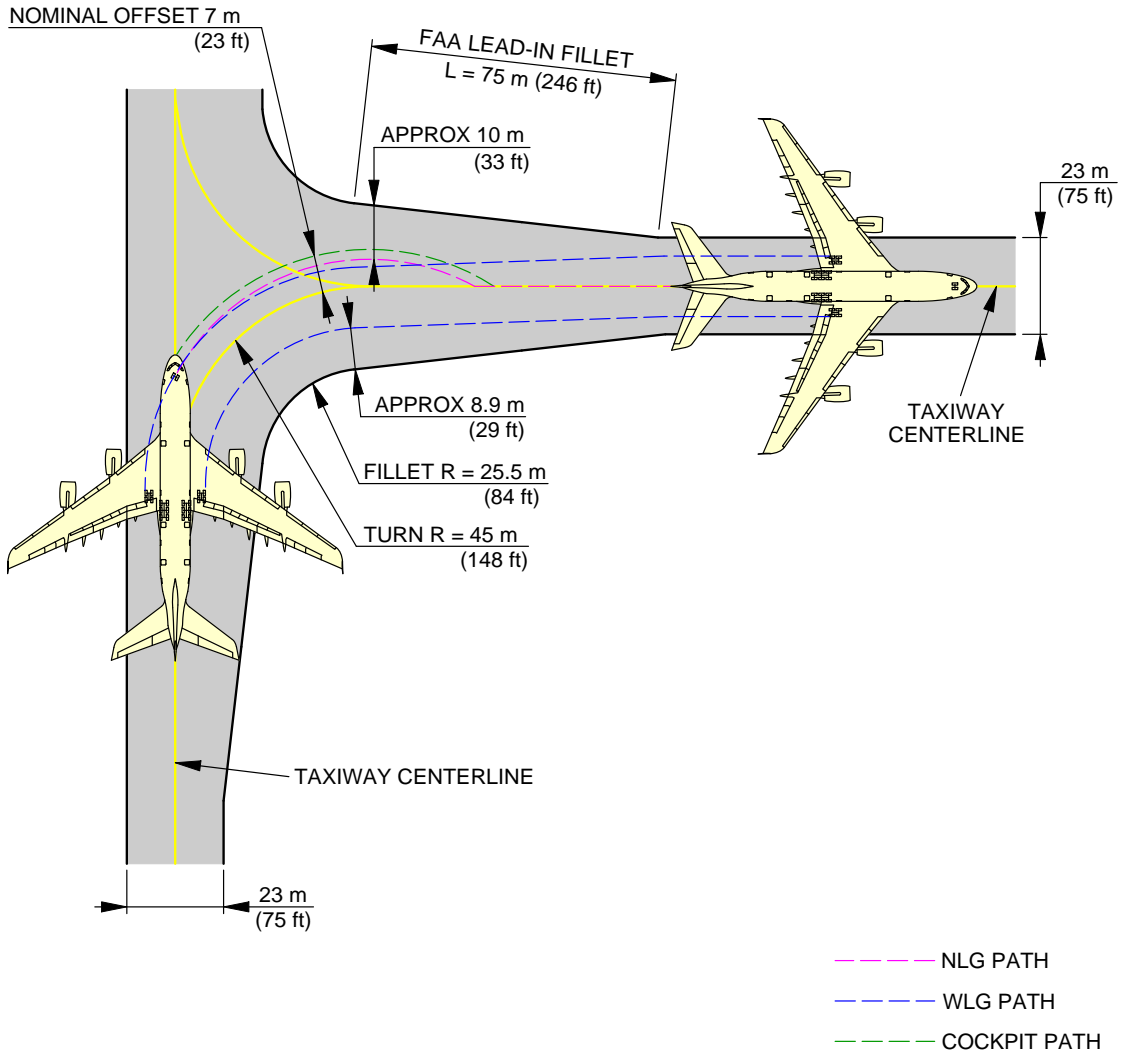

NOTE:
FAA GROUP V FACILITIES.

L_AC_040505_1_0010101_01_02

90° Turn – Taxiway to Taxiway
Judgemental Oversteer Method
FIGURE-4-5-5-991-001-A01

****ON A/C A380-800**

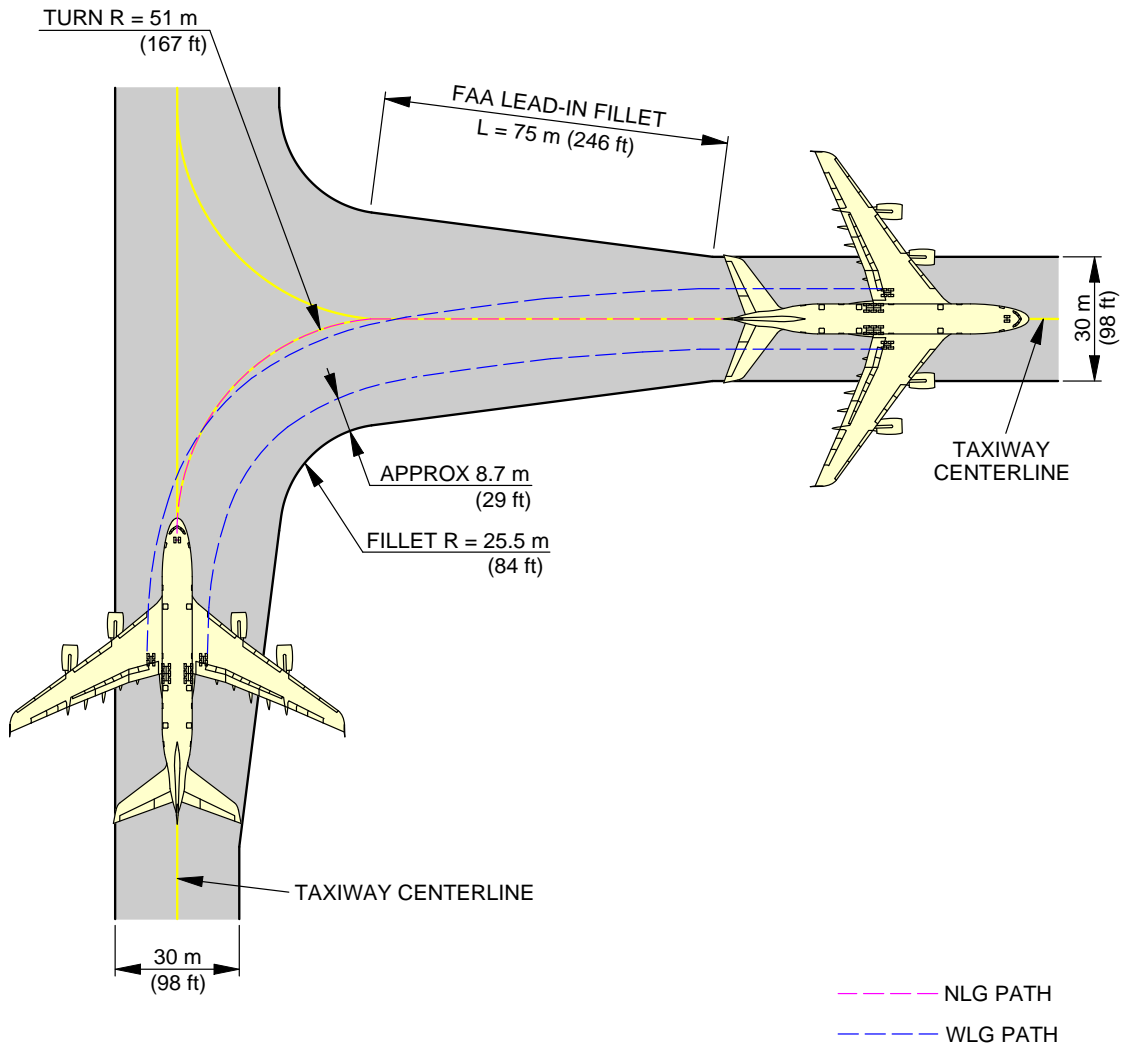

NOTE:
FAA GROUP VI FACILITIES.

L_AC_040505_1_0020101_01_02

90° Turn – Taxiway to Taxiway
Cockpit Tracks Centerline Method
FIGURE-4-5-5-991-002-A01

4-6-0 Runway Holding Bay (Apron)****ON A/C A380-800**Runway Holding Bay (Apron)

1. This section gives the runway holding bay (Apron).

****ON A/C A380-800**

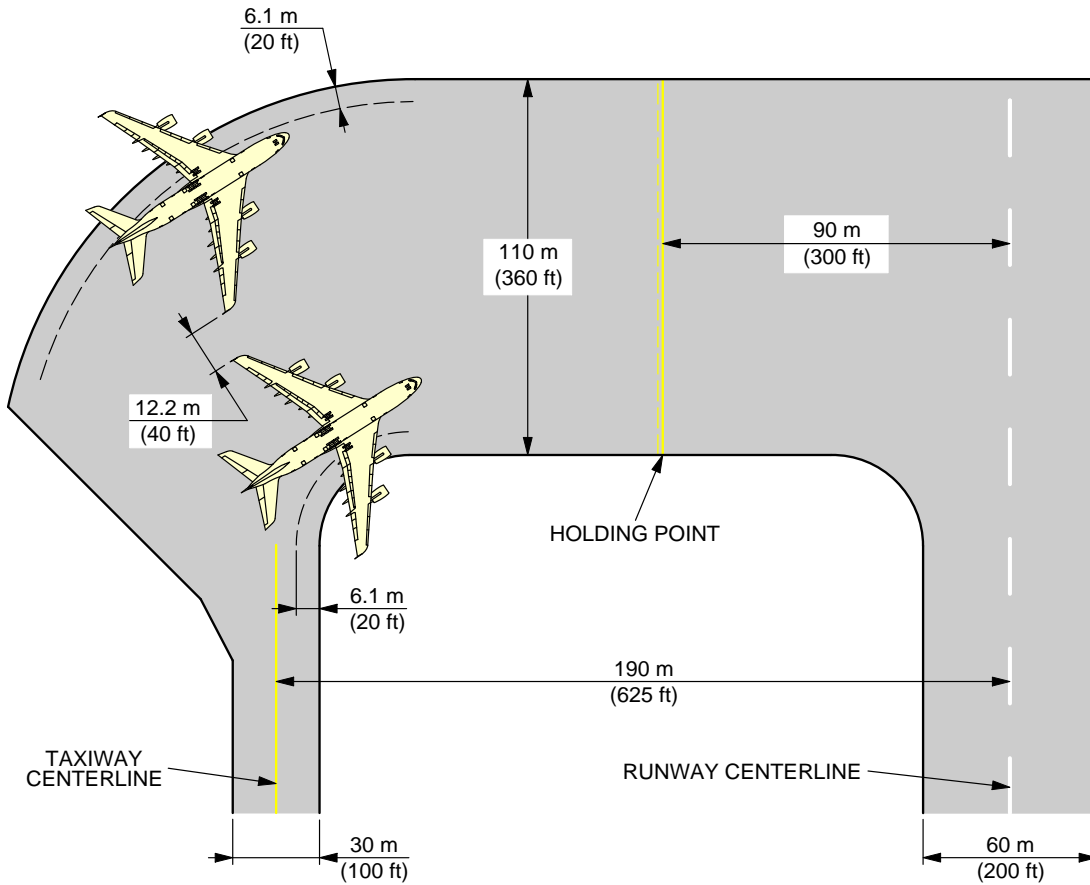

NOTE: COORDINATE WITH USING AIRLINE FOR SPECIFIC PLANNED OPERATING PROCEDURE.

L_AC_040600_1_0010101_01_01

Runway Holding Bay (Apron)
FIGURE-4-6-0-991-001-A01

4-7-0 Minimum Line-Up Distance Corrections

**ON A/C A380-800

Minimum Line-Up Distance Corrections

1. The ground manoeuvres were performed using asymmetric thrust and differential only braking to initiate the turn.

Manoeuvres of this section are calculated with the turn characteristics given in section 04-02-00.
TODA: Take-Off Available Distance
ASDA: Acceleration-Stop Distance Available

2. 90° Turn on Runway Entry

This section gives the minimum line-up distance correction for a 90° turn on runway entry. This manoeuvre consists in a 90° turn at minimum turn radius starting with the edge of the WLG at a distance of 4 m (13 ft) from taxiway edge, and finishing with the aircraft aligned on the centerline of the runway, see FIGURE 4-7-0-991-003-A.

During the turn, all the clearances must meet the minimum value of 4 m (13 ft) for this category of aircraft as recommended in ICAO Annex 14 (amendment 14).

The 90° turn on a 45 m wide runway with the maximum steering angle will not be in a good alignment. Thus a lower steering angle is used.

3. 180° Turn on Runway Turn Pad

This section gives the minimum line-up distance correction for a 180° turn on runway turn pad. This manoeuvre consists in a 180° turn at minimum turn radius on a standard ICAO runway turn pad geometry.

It starts with the edge of the WLG at 4 m (13 ft) from pavement edge, and it finishes with the aircraft aligned on the centerline of the runway, see FIGURE 4-7-0-991-004-A.

During the turn, all the clearances must meet the minimum value of 4 m (13 ft) for this category of aircraft as recommended in ICAO Annex 14 (amendment 14).

4. 180° Turn on Runway Width

This section gives the minimum line-up distance correction for a 180° turn on runway width. For this manoeuvre, the pavement width is considered to be the runway width, which is a frozen parameter (45 m (150 ft) and 60 m (200 ft)).

As per the "180° turn on runway" standard operating procedures described in the Flight Crew Operating Manual, the aircraft is initially angled with respect to runway centerline when starting the 180° turn, see FIGURE 4-7-0-991-005-A.

During the turn, all the clearances must meet the minimum value of 4 m (13 ft) for this category of aircraft as recommended in ICAO Annex 14 (amendment 14).

NOTE : The minimum line-up distances may need a steering angle lower than the maximum one.

****ON A/C A380-800**

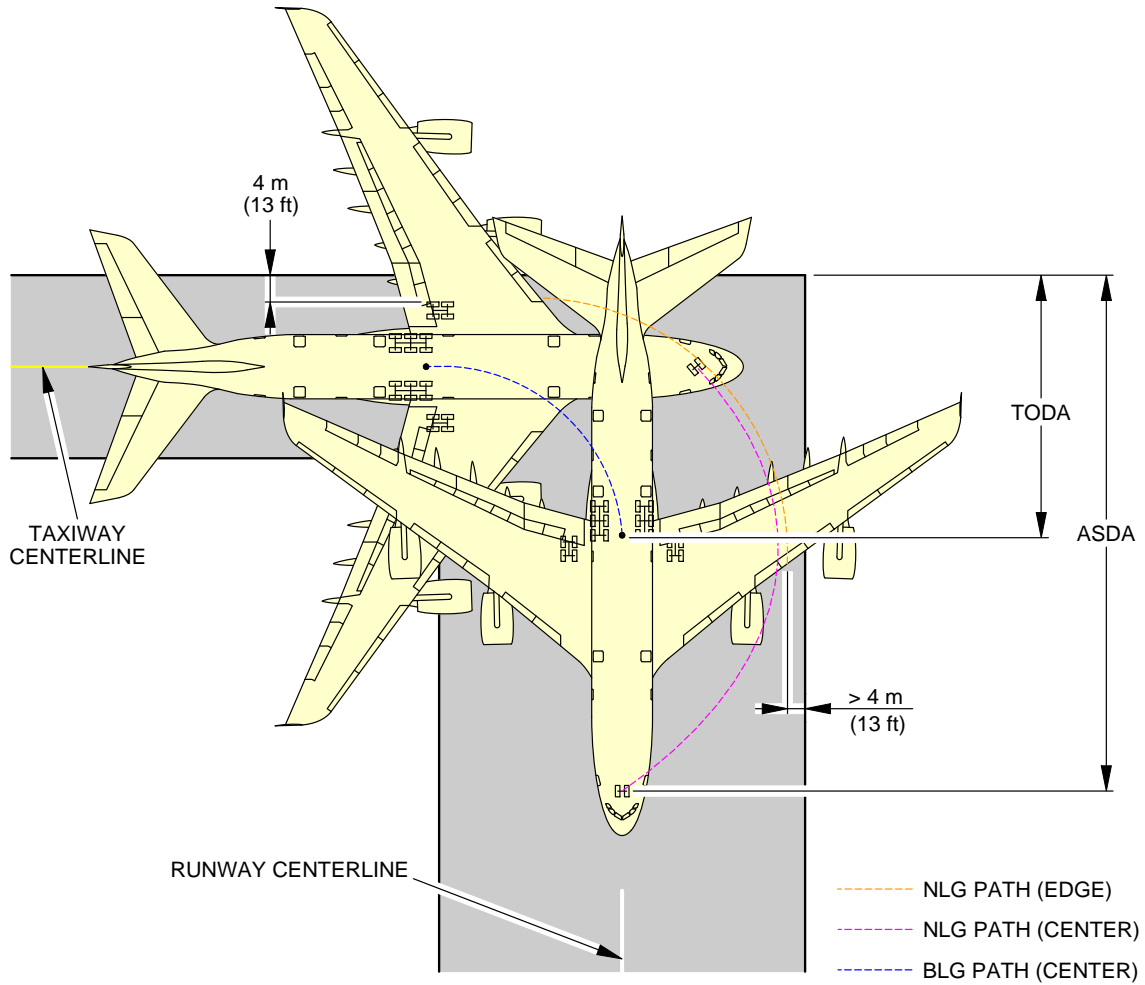

90° TURN ON RUNWAY ENTRY									
AIRCRAFT TYPE	MAX STEERING ANGLE	45 m (150 ft) WIDE RUNWAY (STANDARD WIDTH)				60 m (200 ft) WIDE RUNWAY			
		MINIMUM LINE-UP DISTANCE CORRECTION				MINIMUM LINE-UP DISTANCE CORRECTION			
		ON TODA		ON ASDA		ON TODA		ON ASDA	
A380-800	70°	27.5 m	90 ft	57.3 m	188 ft	22.3 m	73 ft	52.4 m	172 ft

NOTE:

ASDA: ACCELERATION-STOP DISTANCE AVAILABLE
 TODA: TAKE-OFF DISTANCE AVAILABLE

L_AC_040700_1_0030101_01_01

Minimum Line-Up Distance Corrections
 90° Turn on Runway Entry
 FIGURE-4-7-0-991-003-A01

****ON A/C A380-800**

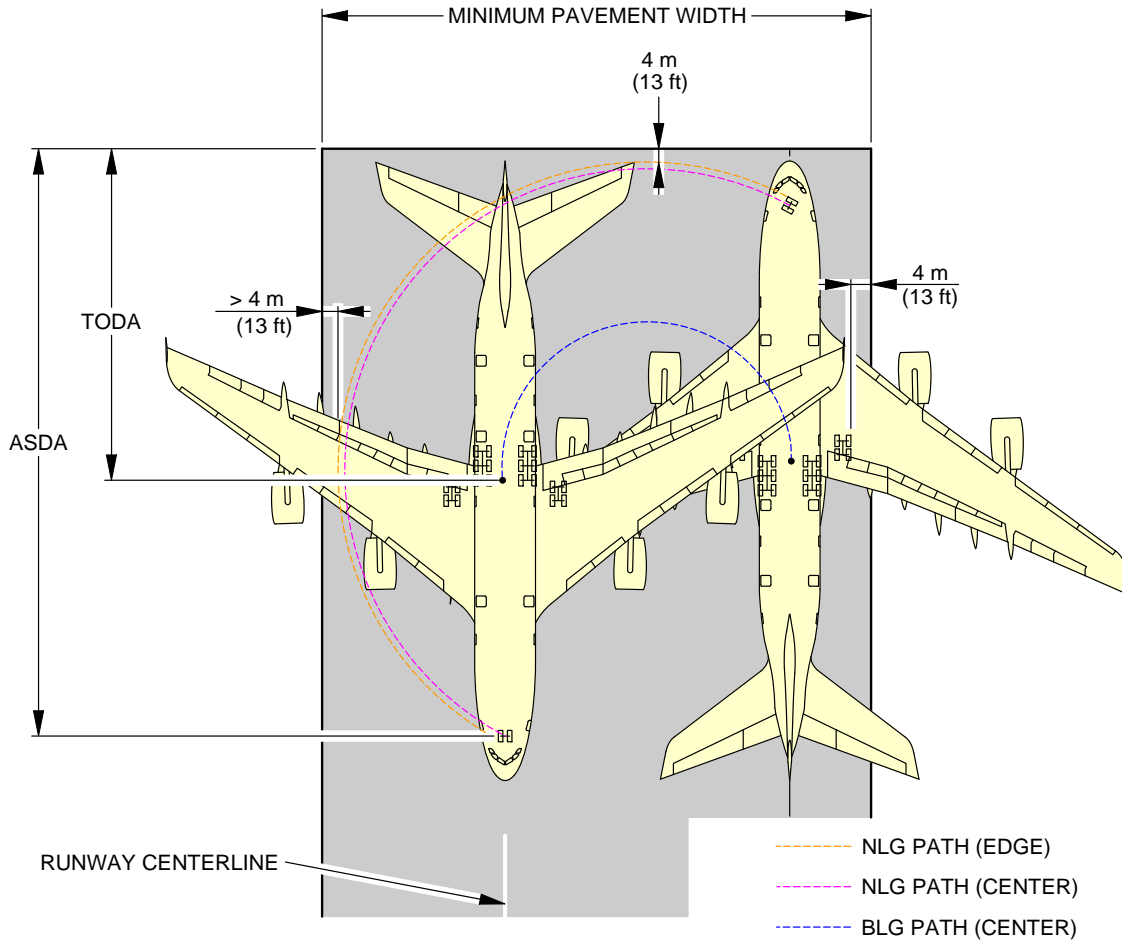

180° TURN ON RUNWAY TURNPAD													
AIRCRAFT TYPE	MAX STEERING ANGLE	45 m (150 ft) WIDE RUNWAY (STANDARD WIDTH)				60 m (200 ft) WIDE RUNWAY							
		MINIMUM LINE-UP DISTANCE CORRECTION				REQUIRED MINIMUM PAVEMENT WIDTH							
		ON TODA		ON ASDA		ON TODA		ON ASDA		REQUIRED MINIMUM PAVEMENT WIDTH			
A380-800	70°	38.5 m	126 ft	68.4 m	224 ft	65.7 m	218 ft	36.6 m	120 ft	66.4 m	218 ft	63.5 m	208 ft

NOTE:

ASDA: ACCELERATION-STOP DISTANCE AVAILABLE
 TODA: TAKE-OFF DISTANCE AVAILABLE

L_AC_040700_1_0040101_01_01

Minimum Line-Up Distance Corrections
 180° Turn on Runway Turn Pad
 FIGURE-4-7-0-991-004-A01

****ON A/C A380-800**

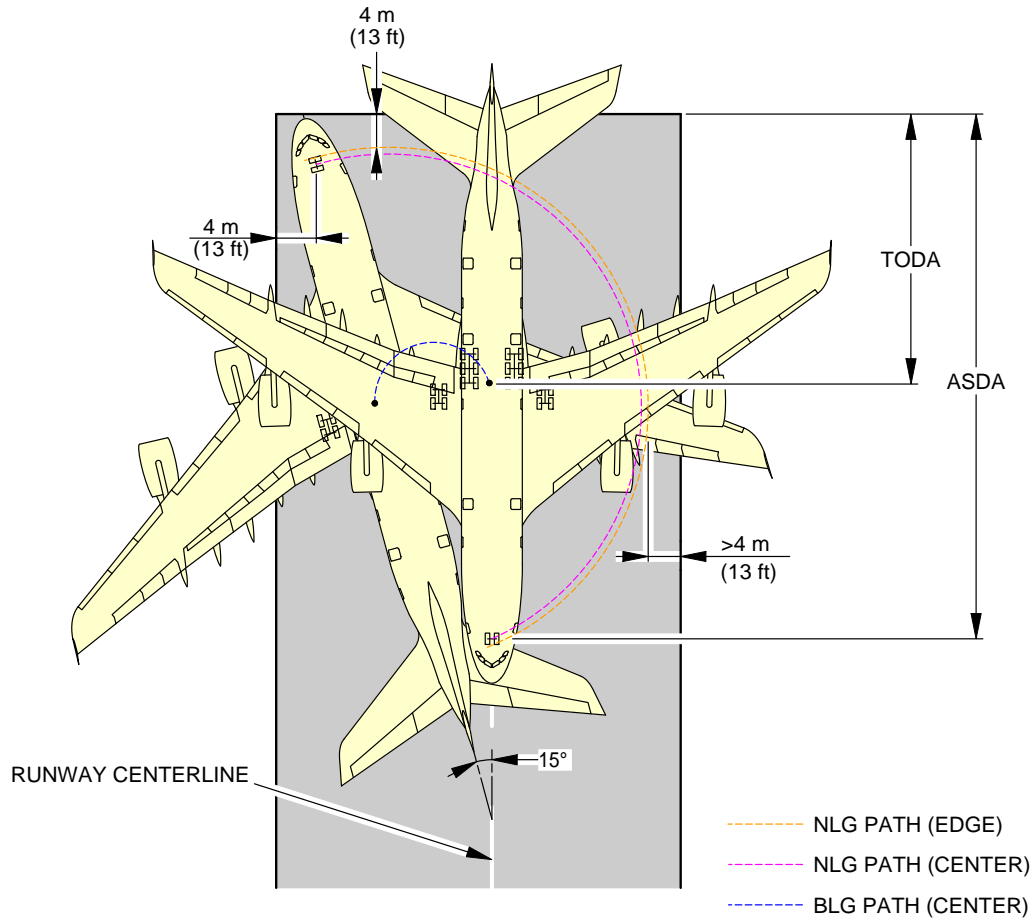

180° TURN ON RUNWAY TURNPAD									
AIRCRAFT TYPE	MAX STEERING ANGLE	45 m (150 ft) WIDE RUNWAY (STANDARD WIDTH)				60 m (200 ft) WIDE RUNWAY			
		MINIMUM LINE-UP DISTANCE CORRECTION				MINIMUM LINE-UP DISTANCE CORRECTION			
		ON TODA		ON ASDA		ON TODA	ON ASDA		
A380-800	70°	NOT POSSIBLE				49.1 m	161 ft	78.9 m	259 ft

NOTE:

ASDA: ACCELERATION-STOP DISTANCE AVAILABLE
 TODA: TAKE-OFF DISTANCE AVAILABLE

L_AC_040700_1_0050101_01_01

Minimum Line-Up Distance Corrections
 180° Turn on Runway Width
 FIGURE-4-7-0-991-005-A01

4-8-0 Aircraft Mooring

****ON A/C A380-800**

Aircraft Mooring

1. This section provides information on aircraft mooring.

****ON A/C A380-800**

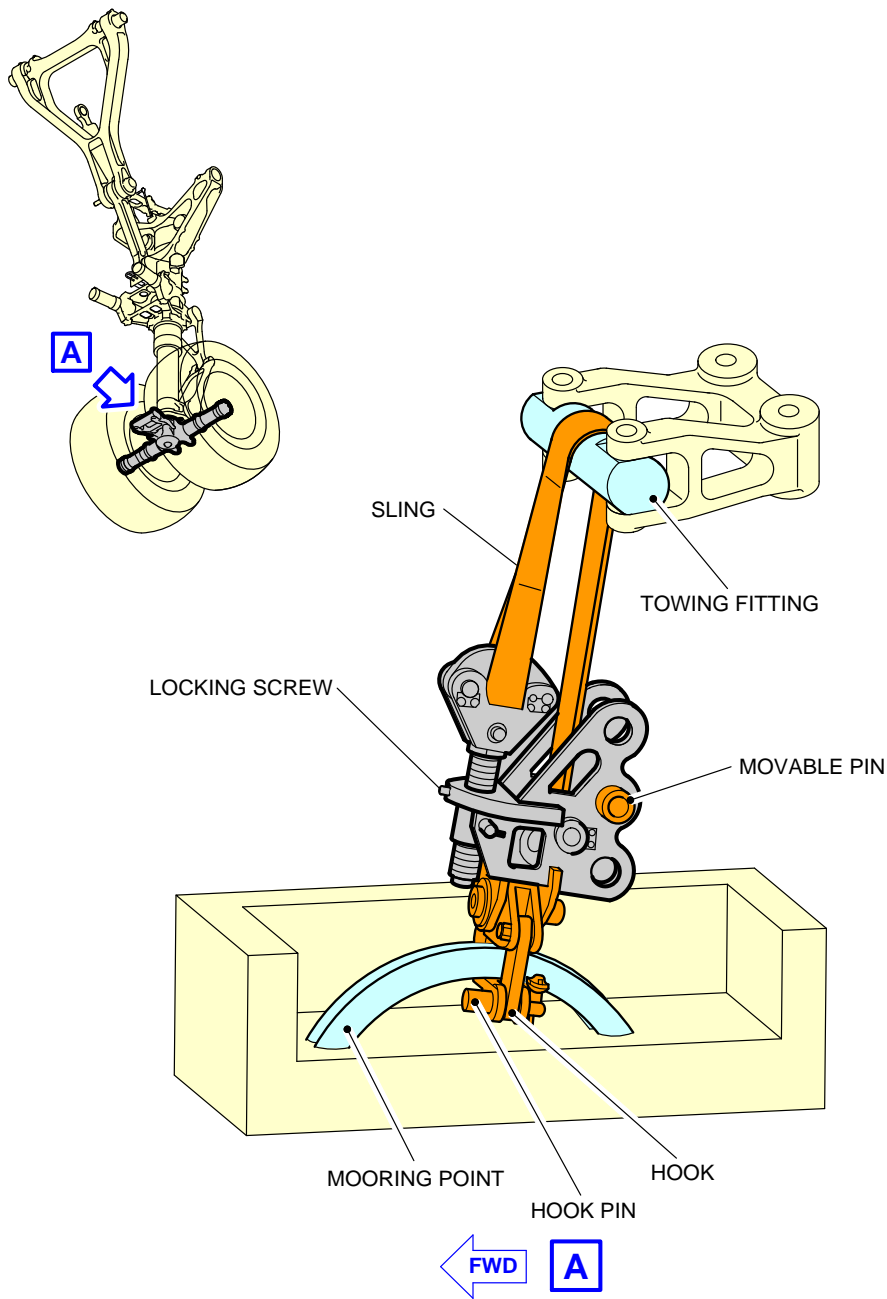

L_AC_040800_1_0010101_01_00

Aircraft Mooring
FIGURE-4-8-0-991-001-A01

TERMINAL SERVICING**5-1-0 Aircraft Servicing Arrangements******ON A/C A380-800**Aircraft Servicing Arrangements

1. This section provides typical ramp layouts, showing the various GSE items in position during typical turn-round scenarios.

These ramp layouts show typical arrangements only. Each operator will have its own specific requirements/regulations for positioning and operation on the ramp.

This table gives the symbols used on servicing diagrams.

GROUND SUPPORT EQUIPMENT	
AC	AIR CONDITIONING UNIT
AS	AIR START UNIT
BULK	BULK TRAIN
CAT	CATERING TRUCK
CB	CONVEYOR BELT
CLEAN	CLEANING TRUCK
FUEL	FUEL HYDRANT DISPENSER or TANKER
GPU	GROUND POWER UNIT
LDCL	LOWER DECK CARGO LOADER
LV	LAVATORY VEHICLE
PBB	PASSENGER BOARDING BRIDGE
PS	PASSENGER STAIRS
TOW	TOW TRACTOR
UDCAT	UPPER DECK CATERING TRUCK
ULD	ULD TRAIN
WV	POTABLE WATER VEHICLE

5-1-1 Typical Ramp Layout (Open Apron)

****ON A/C A380-800**

Typical Ramp Layout (Open Apron)

1. This section provides the typical ramp layout (Open Apron).
The Stand Safety Line delimits the Aircraft Safety Area (minimum distance of 7.5 m (24.61 ft) from the aircraft). No vehicle must be parked in this area before complete stop of the aircraft (wheel chocks in position on landing gears) and the beacon lights are off.

****ON A/C A380-800**

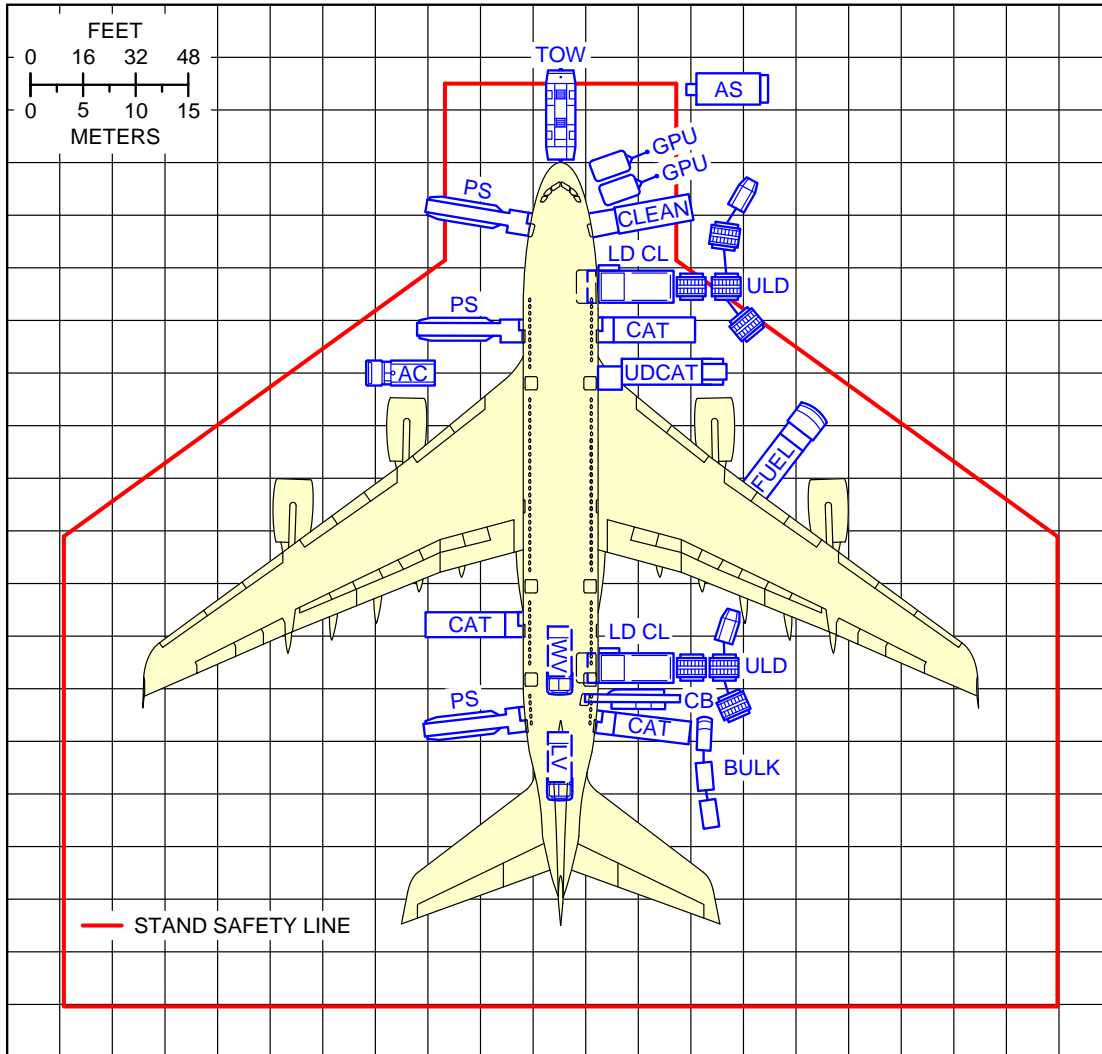

L_AC_050101_1_0010101_01_02

Typical Ramp Layout
Open Apron
FIGURE-5-1-1-991-001-A01

5-1-2 Typical Ramp Layout (Gate)

****ON A/C A380-800**

Typical Ramp Layout (Gate)

1. This section provides the baseline ramp layout (Gate).

The Stand Safety Line delimits the Aircraft Safety Area (minimum distance of 7.5 m (24.61 ft) from the aircraft). No vehicle must be parked in this area before complete stop of the aircraft (wheel chocks in position on landing gears) and the beacon lights are off.

****ON A/C A380-800**

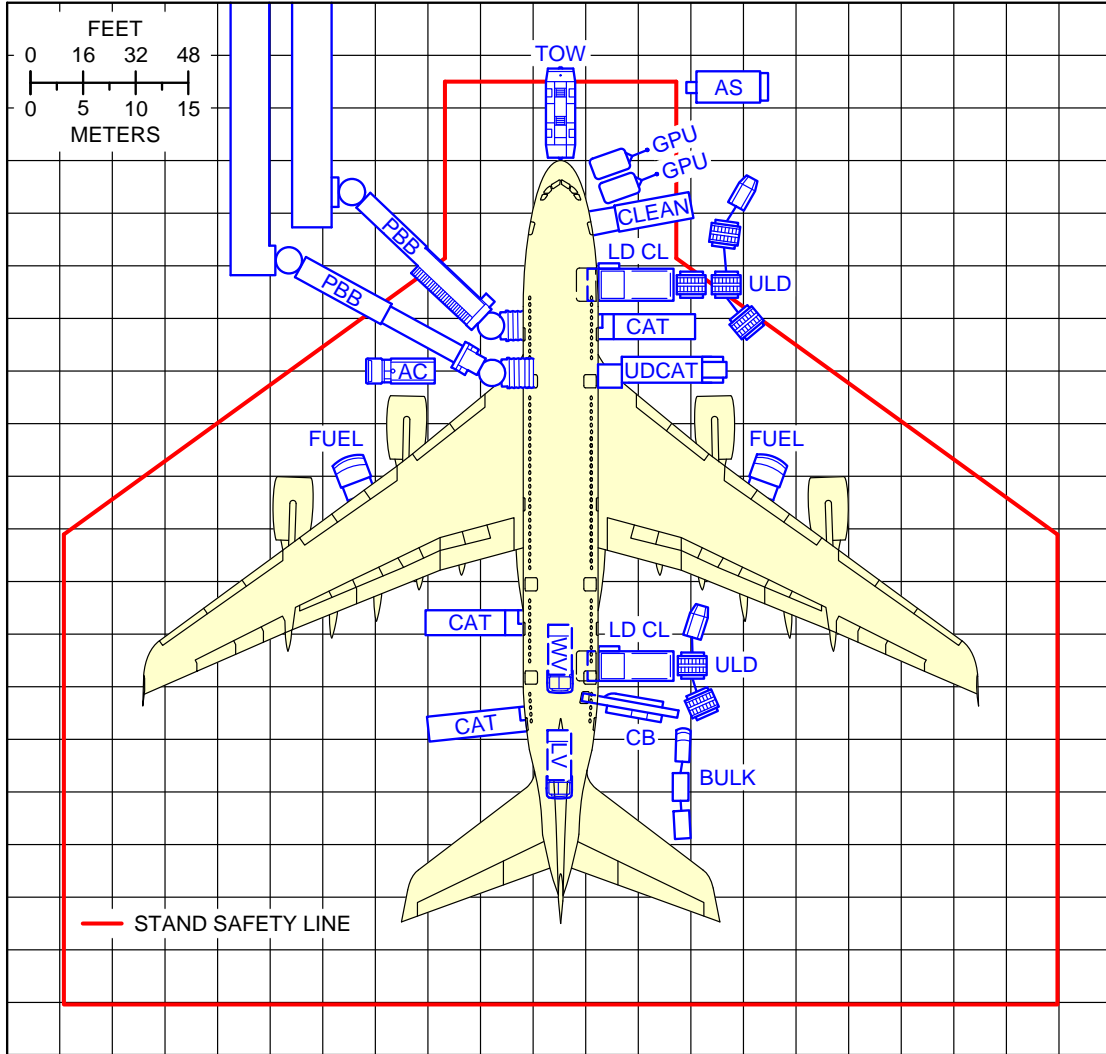

L_AC_050102_1_0010101_01_02

Typical Ramp Layout
Gate
FIGURE-5-1-2-991-001-A01

5-2-1 Typical Turn-Round Time - Standard Servicing Via Main Deck and Upper Deck

**ON A/C A380-800

Typical Turn-Round Time - Standard Servicing Via Main Deck and Upper Deck

1. This section provides a typical turn-round time chart showing the typical time for ramp activities during aircraft turn-round.
Actual times may vary due to each operator's specific practices, resources, equipment and operating conditions.
2. Assumptions used for standard servicing via main and upper deck during typical turn-round time

A. PASSENGER HANDLING

555 pax (22 F/C + 96 B/C + 437 Y/C).

All passengers deplane and board the aircraft.

2 Passenger Boarding Bridges (PBB) used at doors M2L and U1L.

Equipment positioning main deck + opening door = +3 min.

Closing door + equipment removal main deck = +3 min.

Equipment positioning upper deck + opening door = +4 min.

Closing door + equipment removal upper deck = +4 min.

No Passenger with Reduced Mobility (PRM) on board.

Deplaning:

- 356 pax at door M2L (22 F/C + 334 Y/C)
- 199 pax at door U1L (96 B/C + 103 Y/C)
- Deplaning rate = 25 pax/min per door
- Priority deplaning for premium passengers.

Boarding:

- 356 pax at door M2L (22 F/C + 334 Y/C)
- 199 pax at door U1L (96 B/C + 103 Y/C)
- Boarding rate = 15 pax/min per door
- Last Pax Seating allowance (LPS) + headcounting = +4 min.

B. CARGO

2 cargo loaders + 1 belt loader.

Opening door + equipment positioning = +2.5 min.

Equipment removal + closing door = +2.5 min.

100% cargo exchange:

- FWD cargo compartment: 20 containers
- AFT cargo compartment: 16 containers
- Bulk cargo compartment: 1 000 kg (2 205 lb).

Container unloading/loading times:

- Unloading = 1.2 min/container
- Loading = 1.4 min/container.

Bulk unloading/loading times:

- Unloading = 110 kg/min (243 lb/min)
- Loading = 95 kg/min (209 lb/min).

C. REFUELING

254 778 l (67 305 US gal) at 40 psig with 4 hoses.

Dispenser positioning + connection = +8 min.

Disconnection + dispenser removal = +8 min.

D. CLEANING

Cleaning is performed in available time.

E. CATERING

3 main deck catering trucks + 1 upper deck catering truck.

Main deck equipment positioning + door opening = +5 min.

Main deck closing door + equipment removal = 3 min.

Upper deck equipment positioning + door opening = +9 min.

Upper deck closing door + equipment removal = 4 min.

Full Size Trolley Equivalent (FSTE) to unload and load: 78 FSTE

- 28 FSTE at door M2R
- 16 FSTE at door M4R
- 23 FSTE at door U1R
- 11 FSTE at door U3 (via M5L and rear lift).

Time for trolley exchange = 1.5 min per FSTE.

Time for trolley exchange via lift = 2 min per FSTE.

F. GROUND HANDLING/SERVICING

Start of operations:

- Bridges/stairs: $t_0 = 0$
- Other equipment: $t = t_0$.

Ground Power Unit (GPU): up to 4 x 90 kVA.

Air conditioning: up to 4 hoses.

Waste water servicing: draining + rinsing.

Potable water servicing: 100% uplift, 1 700 l (449 US gal).

****ON A/C A380-800**

TRT: 90 min

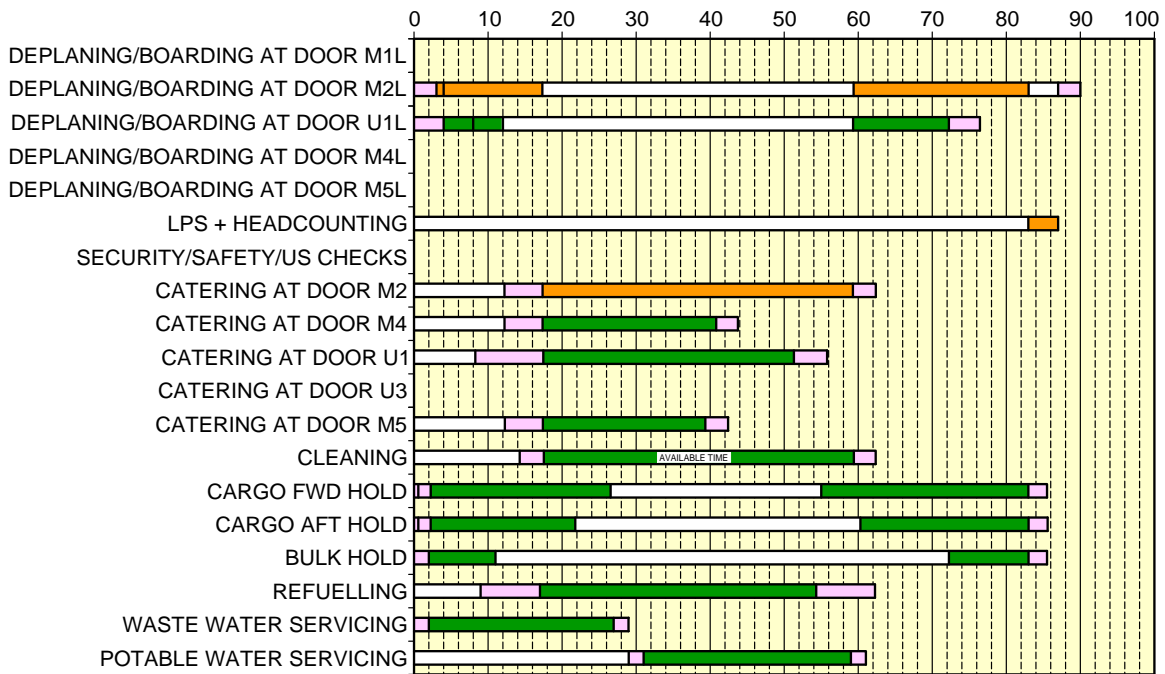

- GSE POSITIONING/REMOVAL
- ACTIVITY
- CRITICAL PATH

L_AC_050201_1_0020101_01_04

Typical Turn-Round Time
 Servicing Via Main and Upper Deck
 FIGURE-5-2-1-991-002-A01

5-2-2 Typical Turn-Round Time - Servicing Via Main Deck

**ON A/C A380-800

Typical Turn-Round Time - Servicing Via Main Deck

1. This section provides a typical turn-round time chart showing the typical time for ramp activities during aircraft turn-round.

Actual times may vary due to each operator's specific practices, resources, equipment and operating conditions.

2. Assumptions used for standard servicing via main deck only during typical turn-round time

A. PASSENGER HANDLING

555 pax (22 F/C + 96 B/C + 437 Y/C).

All passengers deplane and board the aircraft.

2 Passenger Boarding Bridges (PBB) used at doors M1L and M2L.

Equipment positioning main deck + opening door = +3 min.

Closing door + equipment removal main deck = +3 min.

No Passenger with Reduced Mobility (PRM) on board.

Deplaning:

- 221 pax at door M1L (22 F/C + 96 B/C + 103 Y/C)
- 334 pax at door M2L (334 Y/C)
- Deplaning rate = 25 pax/min per door
- Priority deplaning for premium passengers.

Boarding:

- 221 pax at door M1L (22 F/C + 96 B/C + 103 Y/C)
- 334 pax at door M2L (334 Y/C)
- Boarding rate = 15 pax/min per door
- Last Pax Seating allowance (LPS) + headcounting = +4 min.

B. CARGO

2 cargo loaders + 1 belt loader.

Opening door + equipment positioning = +2.5 min.

Equipment removal + closing door = +2.5 min.

100% cargo exchange:

- FWD cargo compartment: 20 containers
- AFT cargo compartment: 16 containers

- Bulk compartment: 1 000 kg (2 205 lb).

Container unloading/loading times:

- Unloading = 1.2 min/container
- Loading = 1.4 min/container.

Bulk unloading/loading times:

- Unloading = 110 kg/min (243 lb/min)
- Loading = 95 kg/min (209 lb/min).

C. REFUELING

254 778 l (67 305 US gal) at 40 psig with 4 hoses.

Dispenser positioning + connection = +8 min.

Disconnection + dispenser removal = +8 min.

D. CLEANING

Cleaning is performed in available time.

E. CATERING

3 main deck catering trucks.

Main deck equipment positioning + door opening = +5 min.

Main deck closing door + equipment removal = +3 min.

Full Size Trolley Equivalent (FSTE) to unload and load: 78 FSTE.

- 28 FSTE at door M2R
- 16 FSTE at door M4R
- 23 FSTE at door U1R (via M2R and front lift)
- 11 FSTE at door U3 (via M5L and rear lift).

Time for trolley exchange = 1.5 min per FSTE.

Time for trolley exchange via lift = 2 min per FSTE.

F. GROUND HANDLING/SERVICING

Start of operations:

- Bridges/stairs: $t_0 = 0$
- Other equipment: $t = t_0$.

Ground Power Unit (GPU): up to 4 x 90 kVA.

Air conditioning: up to 4 hoses.

Waste water servicing: draining + rinsing.

Potable water servicing: 100% uplift, 1 700 l (449 US gal).

****ON A/C A380-800**

TRT: 134 min

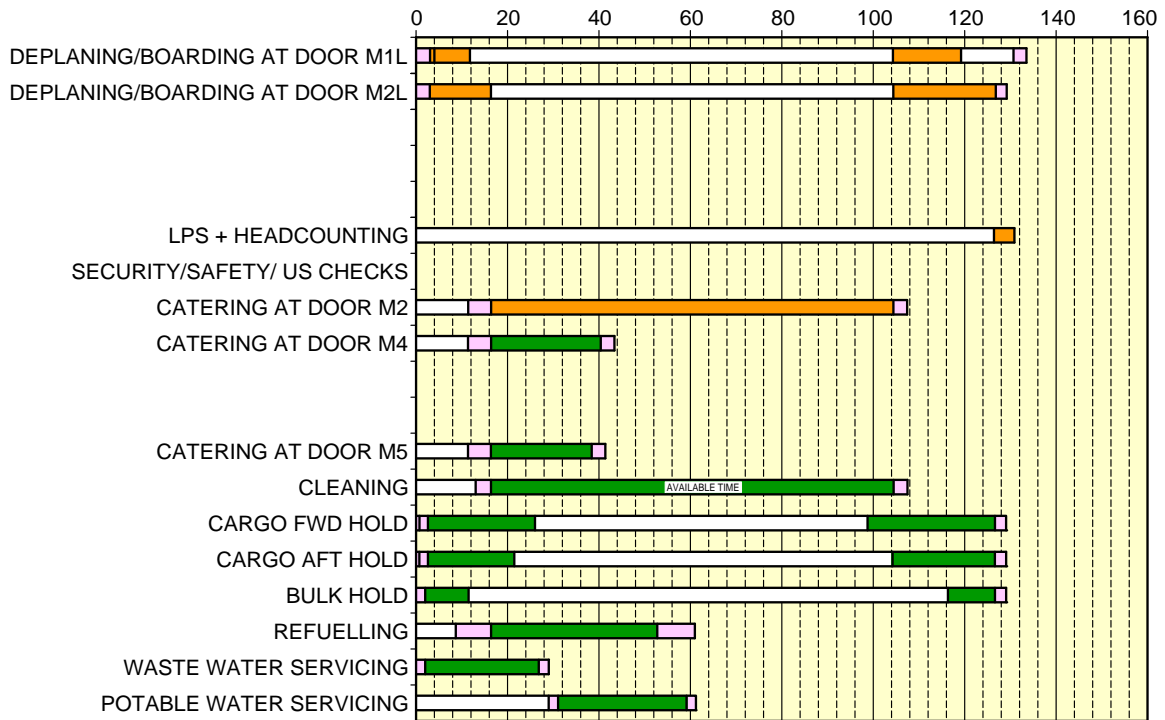

- GSE POSITIONING/REMOVAL
- ACTIVITY
- CRITICAL PATH

L_AC_050202_1_0010101_01_04

Typical Turn-Round Time
 Servicing Via Main Deck
 FIGURE-5-2-2-991-001-A01

5-4-1 Ground Service Connections Layout

****ON A/C A380-800**

Ground Service Connections Layout

1. This section gives the ground service connections layout.

****ON A/C A380-800**

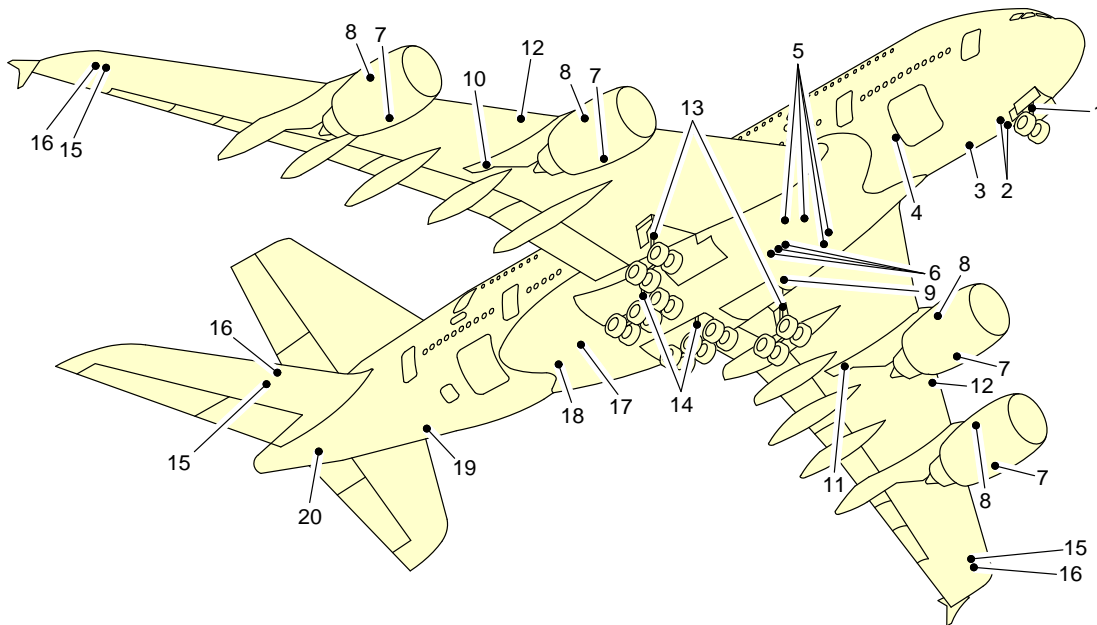

- | | |
|---|---------------------------------------|
| 1 - GROUNDING POINT NLG | 11 - GREEN HYDRAULIC GROUND CONNECTOR |
| 2 - GROUND ELECTRICAL POWER CONNECTORS | 12 - PRESSURE REFUEL CONNECTORS |
| 3 - POTABLE WATER DRAIN PANEL | 13 - GROUNDING POINT WLG |
| 4 - OXYGEN SYSTEM | 14 - GROUNDING POINT BLG |
| 5 - LOW PRESSURE PRECONDITIONED AIR | 15 - NACA FLAME ARRESTOR |
| 6 - HIGH PRESSURE AIR ENGINE START | 16 - OVERPRESSURE PROTECTOR |
| 7 - VFG AND STARTER OIL FILLING | 17 - REFUEL/DEFUEL CONTROL PANEL |
| 8 - ENGINE OIL FILLING* | 18 - POTABLE WATER SERVICE PANEL |
| 9 - HYDRAULIC RESERVOIR SERVICING PANEL | 19 - TOILET AND WASTE SERVICE PANEL |
| 10 - YELLOW HYDRAULIC GROUND CONNECTOR | 20 - APU OIL FILLING |

NOTE:

* THE ENGINE OIL SERVICING POINTS (8) ARE SHOWN FOR THE RR TRENT 900 ENGINE.
FOR THE GP 7200 ENGINE, THE ENGINE OIL SERVICING POINTS (8) ARE LOCATED SYMMETRICALLY ON THE LH SIDE OF EACH ENGINE.

L_AC_050401_1_0010101_01_03

Ground Service Connections Layout
FIGURE-5-4-1-991-001-A01

5-4-2 Grounding (Earthing) Points

****ON A/C A380-800**

Grounding (Earthing) Points

1. Grounding (Earthing) Points

ACCESS	DISTANCE			
	AFT OF NOSE	FROM AIRCRAFT CENTERLINE		MEAN HEIGHT FROM GROUND
		LH SIDE	RH SIDE	
On Nose Landing Gear leg	5.71 m (18.73 ft)		0.18 m (0.59 ft)	1.39 m (4.56 ft)
On Wing Gear leg (Inboard)	34.21 m (112.24 ft)	5.95 m (19.52 ft)	5.95 m (19.52 ft)	1.24 m (4.07 ft)
On Body Gear leg (Outboard)	37.16 m (121.92 ft)	2.85 m (9.35 ft)	2.85 m (9.35 ft)	1.38 m (4.53 ft)
On Body Gear leg (Inboard)	37.16 m (121.92 ft)	2.41 m (7.91 ft)	2.41 m (7.91 ft)	1.38 m (4.53 ft)

- A. The grounding (earthing) stud on each landing gear is designed for use with a clip-on connector, such as an Appleton TGR.
- B. The grounding (earthing) studs are used to connect the aircraft to approved ground (earth) connection on the ramp or in the hangar for:
 - Refuel/defuel operations
 - Maintenance operations
 - Bad weather conditions.

****ON A/C A380-800**

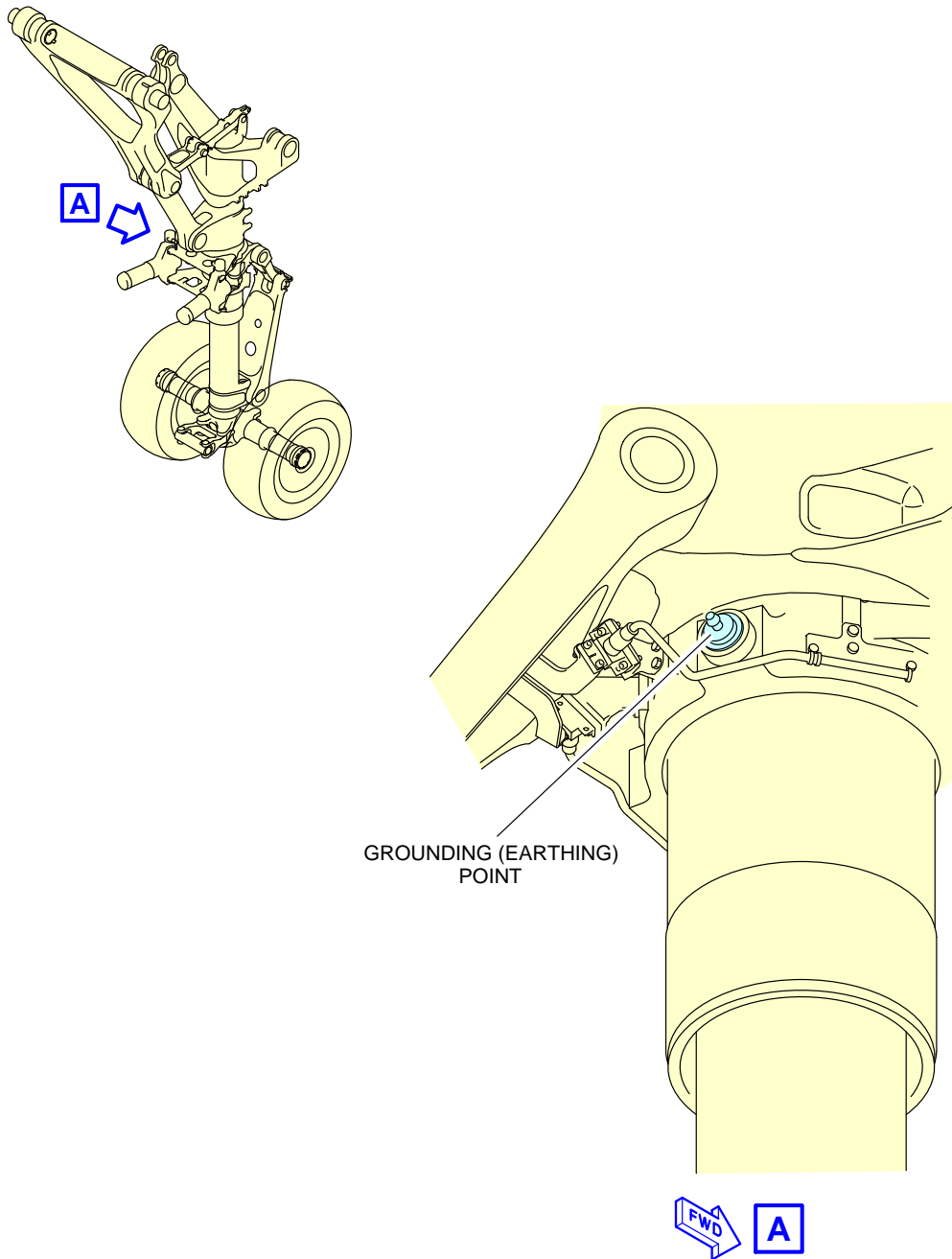

L_AC_050402_1_0010101_01_01

Grounding (Earthing) Point - NLG
FIGURE-5-4-2-991-001-A01

****ON A/C A380-800**

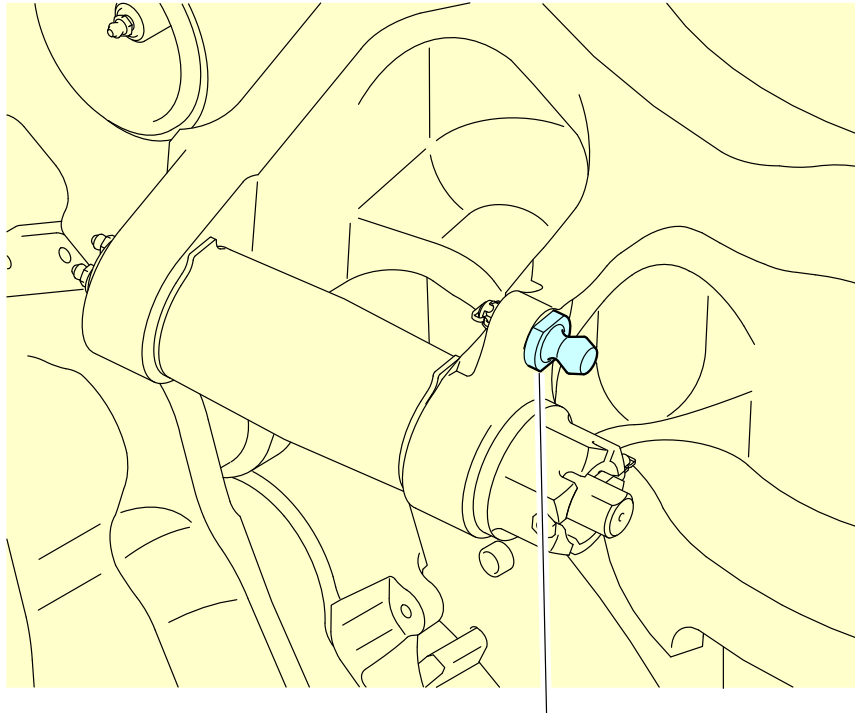
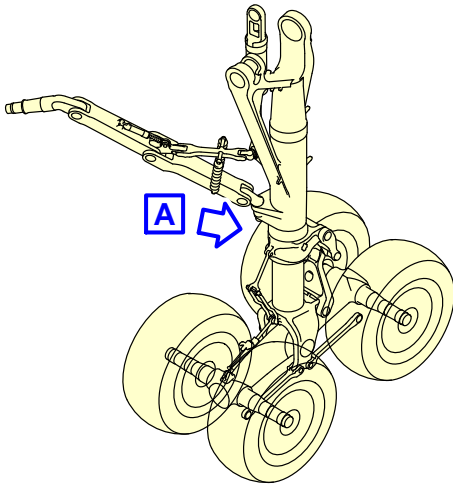

GROUNDING (EARTHING) POINT



L_AC_050402_1_0020101_01_01

Grounding (Earthing) Points - WLG
FIGURE-5-4-2-991-002-A01

****ON A/C A380-800**

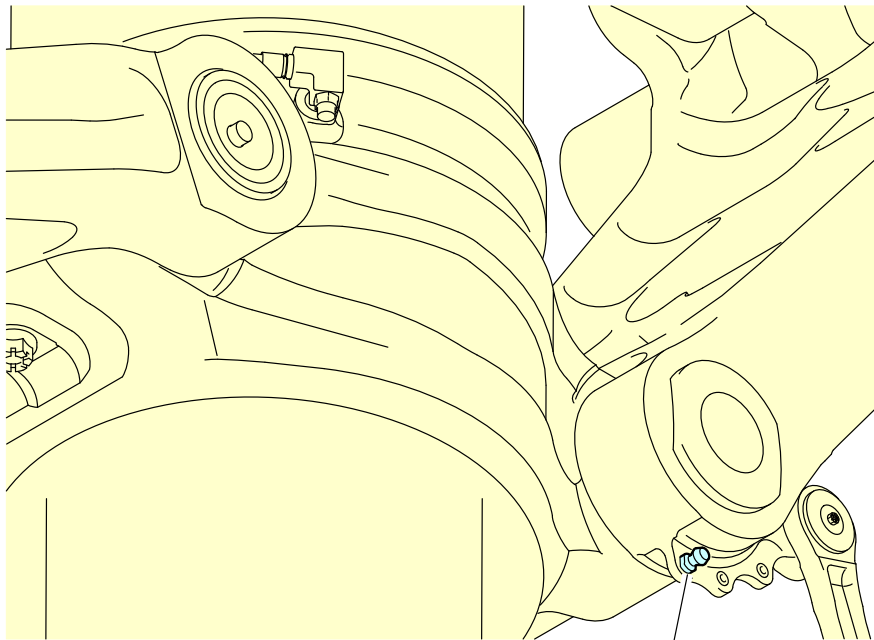
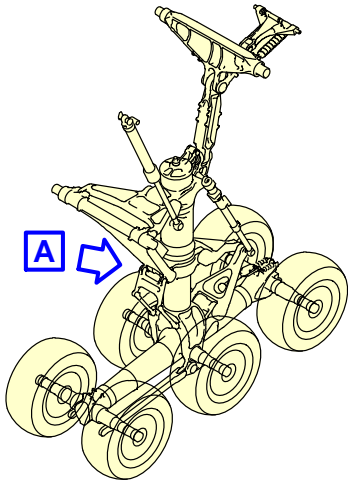

GROUNDING (EARTHING) POINT
(RIGHT ONE SHOWN LEFT ONE SIMILAR)



L_AC_050402_1_0030101_01_01

Grounding (Earthing) Points - BLG
FIGURE-5-4-2-991-003-A01

5-4-3 Hydraulic System

****ON A/C A380-800**

Hydraulic Servicing

1. Ground Service Panel

ACCESS	DISTANCE			
	AFT OF NOSE	FROM AIRCRAFT CENTERLINE		MEAN HEIGHT FROM GROUND
		LH SIDE	RH SIDE	
Hydraulic Reservoir Servicing Panel: Access Door 197CB	31.89 m (104.63 ft)	2.34 m (7.68 ft)		1.71 m (5.61 ft)

A. Connectors

(1) Reservoir Filling:

- One 3022079-312

(2) Reservoir Pressurization/Depressurization:

- One 3022079-324 (pressurization)
- One pressure-switch (green hydraulic reservoir depressurization)
- One pressure-switch (yellow hydraulic reservoir depressurization).

2. Ground Test

ACCESS	DISTANCE			
	AFT OF NOSE	FROM AIRCRAFT CENTERLINE		MEAN HEIGHT FROM GROUND
		LH SIDE	RH SIDE	
Green Hydraulic Ground Connectors: Behind Engine 2 Access Door 469FL	34.67 m (113.75 ft)	14.90 m (48.88 ft)		5.08 m (16.67 ft)
Yellow Hydraulic Ground Connectors:	34.67 m (113.75 ft)		14.90 m (48.88 ft)	5.08 m (16.67 ft)

ACCESS	DISTANCE			MEAN HEIGHT FROM GROUND
	AFT OF NOSE	FROM AIRCRAFT CENTERLINE		
		LH SIDE	RH SIDE	
Behind Engine 3 Access Door 479FL				

A. Connectors

- One D24331000 (Suction)
- One D24330000 (Delivery).

****ON A/C A380-800**

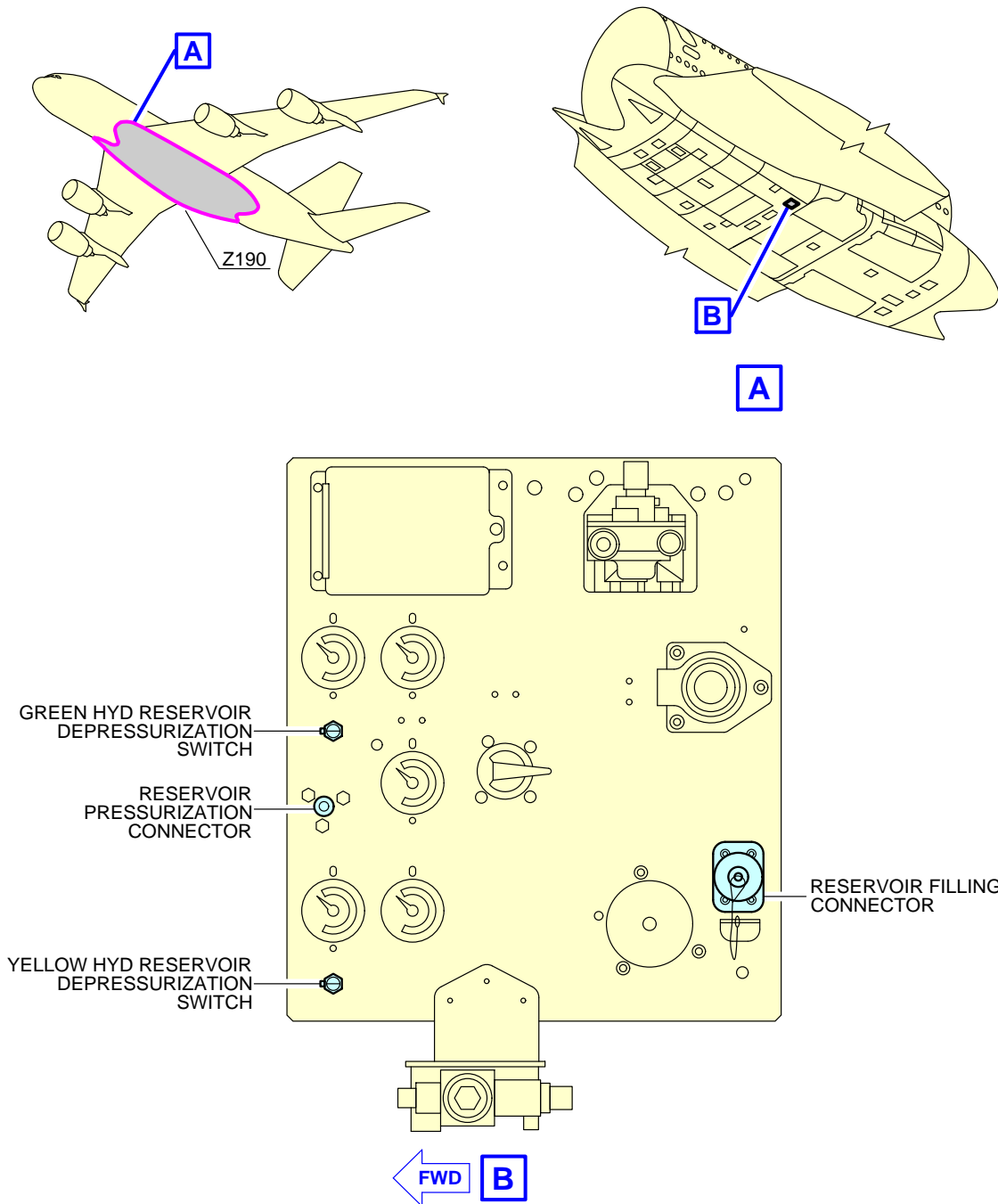

L_AC_050403_1_0010101_01_01

Ground Service Connections
Hydraulic Reservoir Servicing Panel
FIGURE-5-4-3-991-001-A01

****ON A/C A380-800**

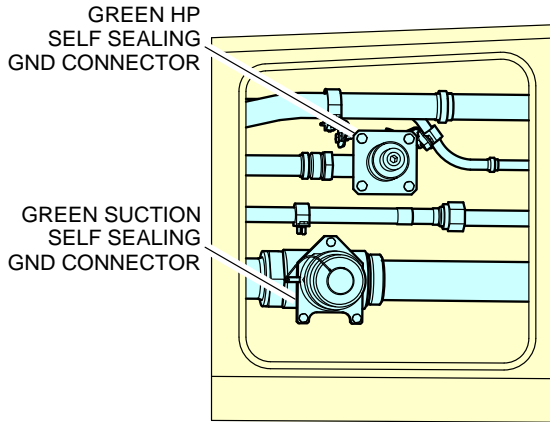
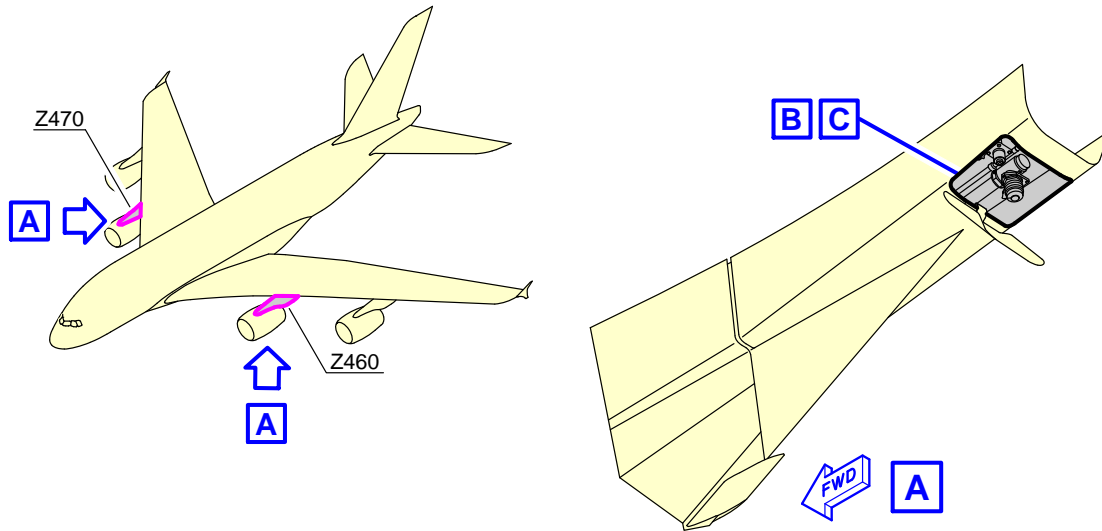

B

FOR LH PYLON

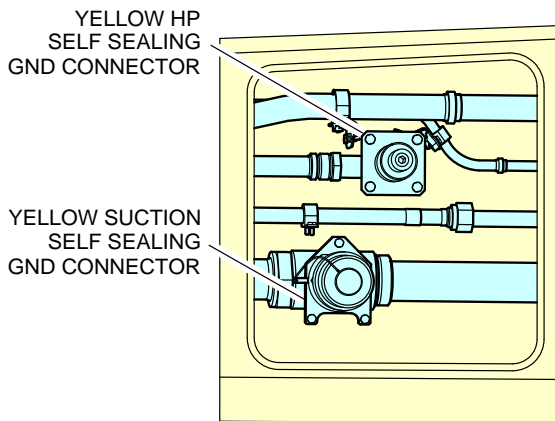

C

FOR RH PYLON

L_AC_050403_1_0020101_01_00

Ground Service Connections
Hydraulic Ground Connections
FIGURE-5-4-3-991-002-A01

5-4-4 Electrical System

****ON A/C A380-800**

Electrical Servicing

1. AC External Power

ACCESS	DISTANCE			
	AFT OF NOSE	FROM AIRCRAFT CENTERLINE		MEAN HEIGHT FROM GROUND
		LH SIDE	RH SIDE	
Right Side Access Door: 134AR	5.99 m (19.65 ft)		0.45 m (1.48 ft)	2.59 m (8.50 ft)
Left Side Access Door: 133AL	5.99 m (19.65 ft)	0.45 m (1.48 ft)		2.59 m (8.50 ft)

2. Technical Specifications

- A. External Power Receptacles:
 - Four receptacles according to MS 90362-3 (without shield MS 17845-1) - 90 kVA.
- B. Power Supply:
 - Three-phase, 115V, 400 Hz.
- C. Electrical Connectors:
 - AC outlets: HUBBELL 5258
 - DC outlets: HUBBELL 7472.

3. Tow Truck Power

ACCESS	DISTANCE			
	AFT OF NOSE	FROM AIRCRAFT CENTERLINE		MEAN HEIGHT FROM GROUND
		LH SIDE	RH SIDE	
NLG Service Panel: 24GC	4.97 m (16.31 ft)		0.25 m (0.82 ft)	1.39 m (4.56 ft)

4. Technical Specifications

- A. Power Supply:
 - Two-Phase, 115 V, 400 Hz
 - 28V DC.
- B. Electrical Connector for Servicing:
 - Bernier, 22-11-10-13 Connector.
- C. Pin Allocation:

Pin Identification	
A	28V DC
B	0V DC
D	115V AC
E	0V AC
G	PWR SPLY
H	INT LOCK

NOTE : The power cable should be extendable in order to guarantee fit and non-interference with nose gear nor tow vehicle during the pick-up and the towing process. The connector shall be secured against pull-out by means of straps against the nose gear.

5. AC Emergency Generation

ACCESS	DISTANCE			
	AFT OF NOSE	FROM AIRCRAFT CENTERLINE		MEAN HEIGHT FROM GROUND
		LH SIDE	RH SIDE	
RAT Safety-Pin Installation Access Panel: 531DL	31.00 m (101.71 ft)	9.50 m (31.17 ft)		3.20 m (10.5 ft)

****ON A/C A380-800**

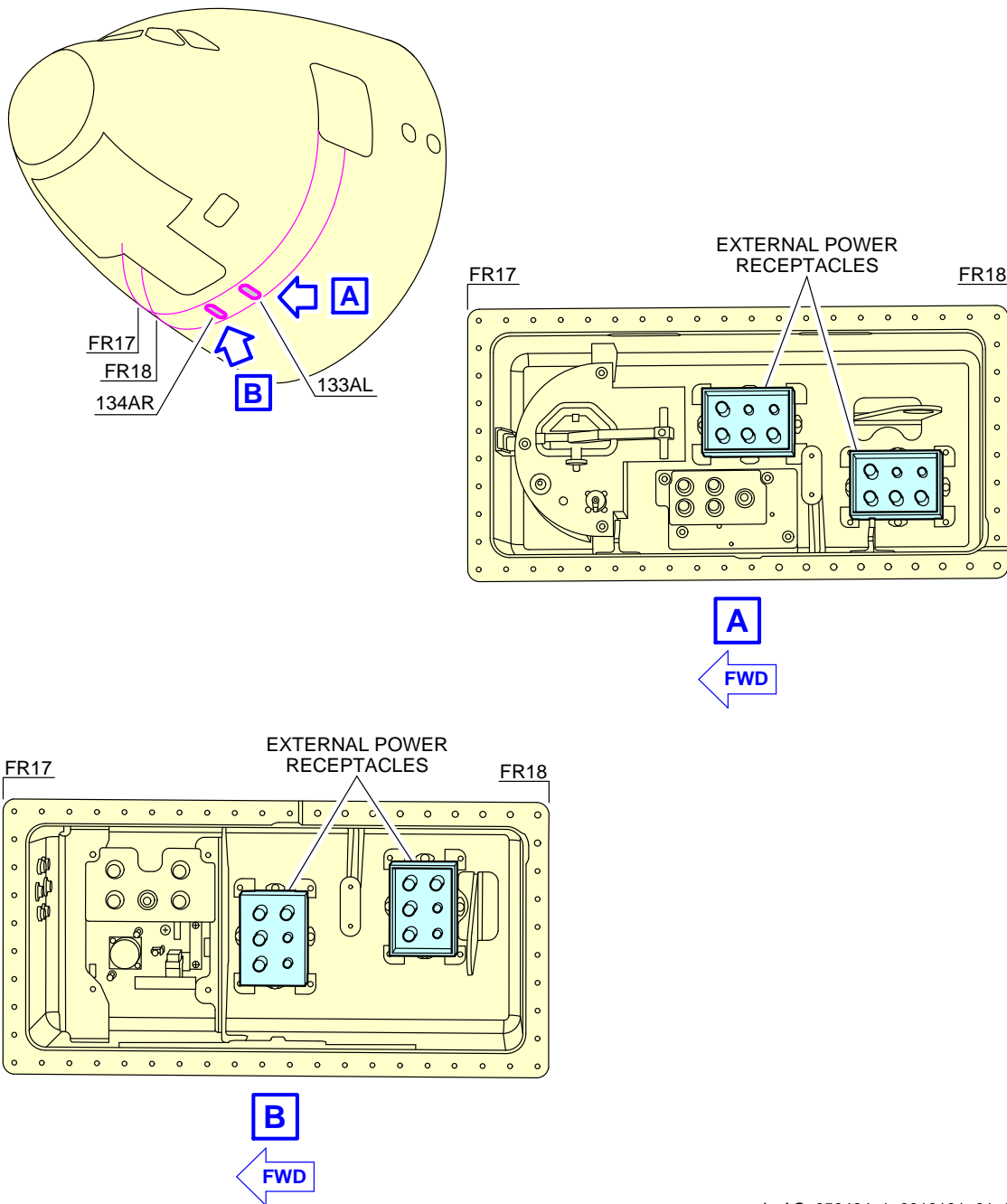

L_AC_050404_1_0010101_01_01

Ground Service Connections
Electrical Service Panel
FIGURE-5-4-4-991-001-A01

****ON A/C A380-800**

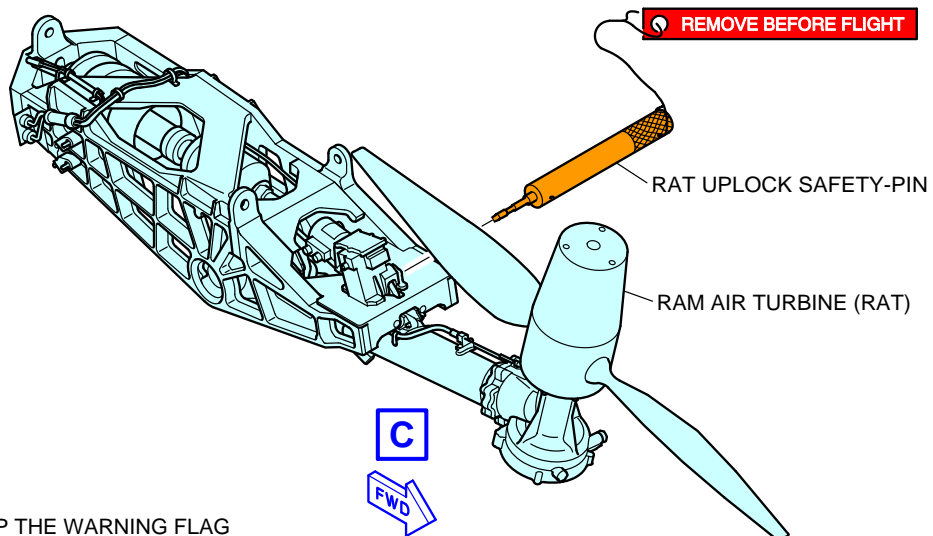
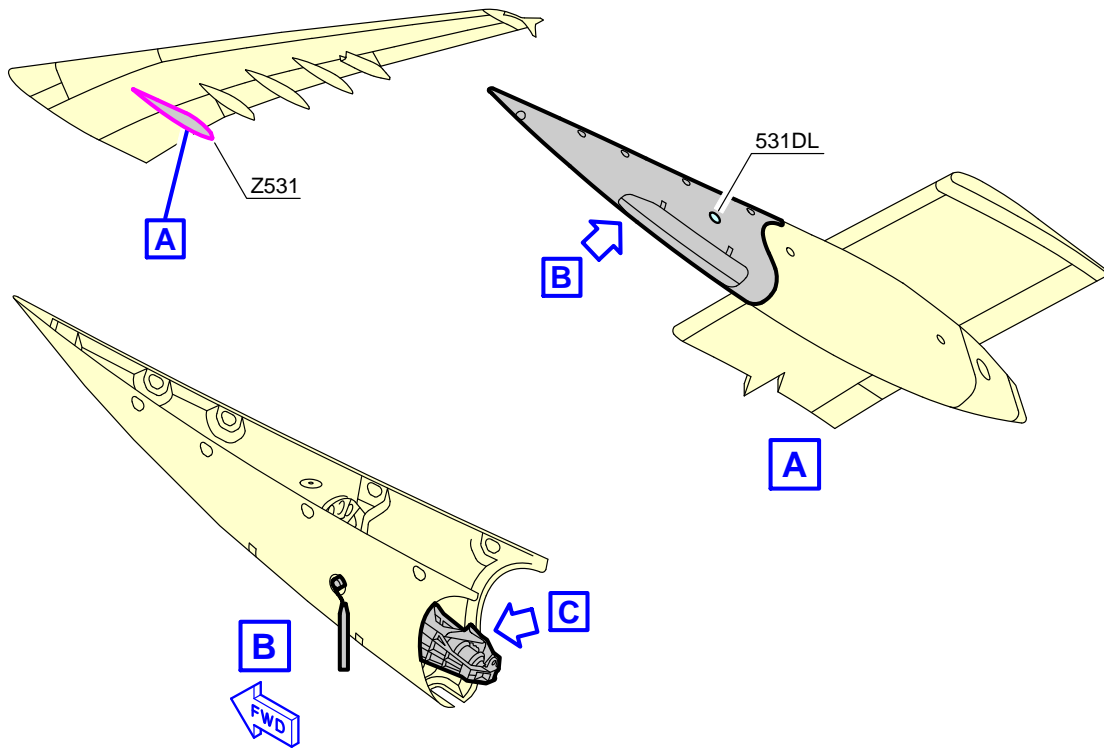

NOTE:
ALWAYS KEEP THE WARNING FLAG
OUT OF THE RAT FAIRING HAND HOLE.

L_AC_050404_1_0050101_01_00

Ground Service Connections
Ram Air Turbine Retracted
FIGURE-5-4-4-991-005-A01

****ON A/C A380-800**

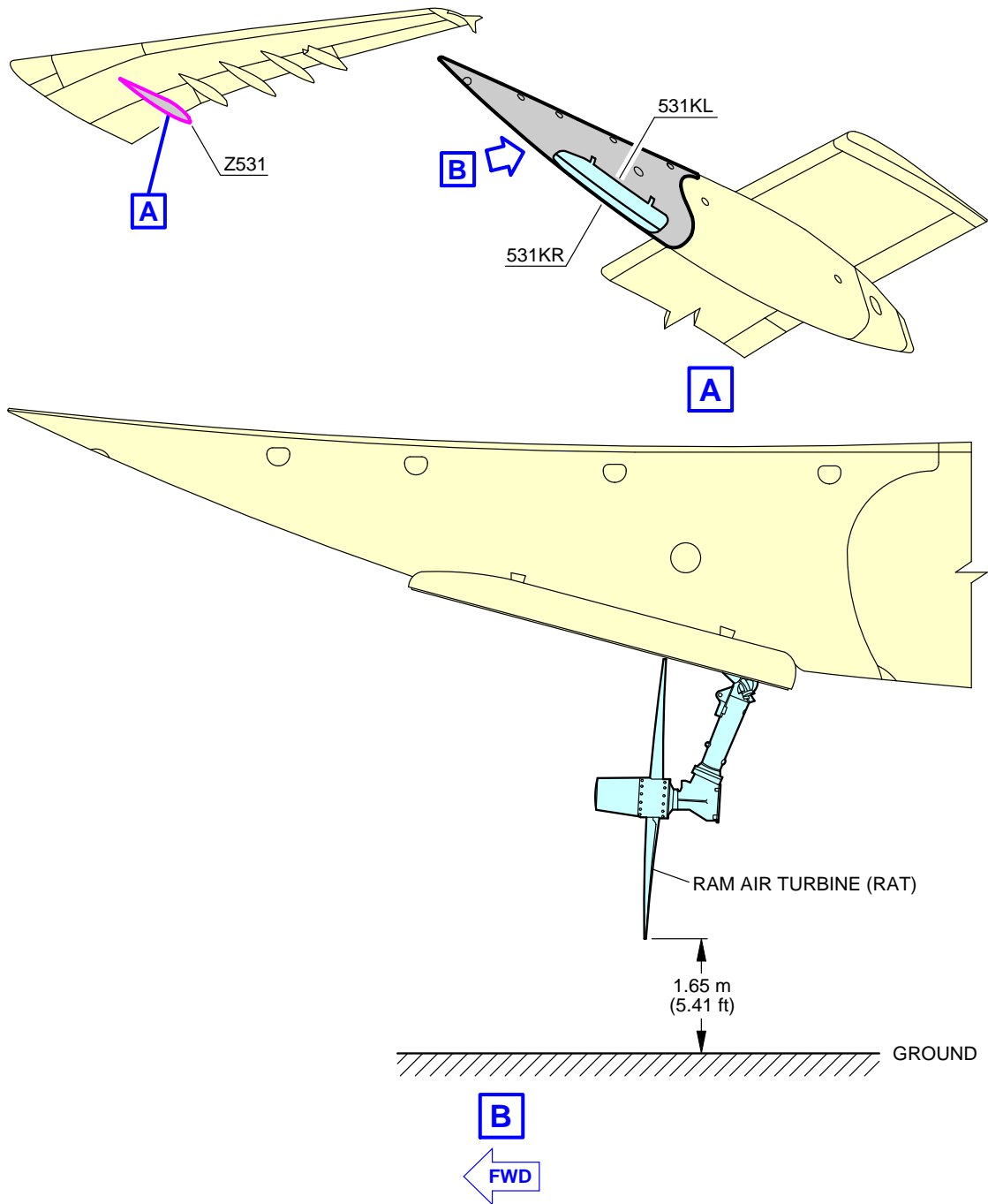

L_AC_050404_1_0060101_01_00

Ground Service Connections
Ram Air Turbine Extended
FIGURE-5-4-4-991-006-A01

5-4-5 Oxygen System

****ON A/C A380-800**

Oxygen System

1. Oxygen System

ACCESS	DISTANCE			
	AFT OF NOSE	FROM AIRCRAFT CENTERLINE		MEAN HEIGHT FROM GROUND
		LH SIDE	RH SIDE	
Access Panels:132AJW 132EJW	13.32 m (43.70 ft)		2.23 m (7.32 ft)	3.25 m (10.66 ft)

- A. Access:
 - Get access to the forward lower-deck cargo-compartment.
 - The access panel to the crew oxygen servicing point is located on the rear triangular area of the FWD cargo door.
- B. Technical Specifications:
 - MIL-DTL-7891 standard service connection
 - Zero, one or two service connections (external charging in the FWD cargo compartment).

****ON A/C A380-800**

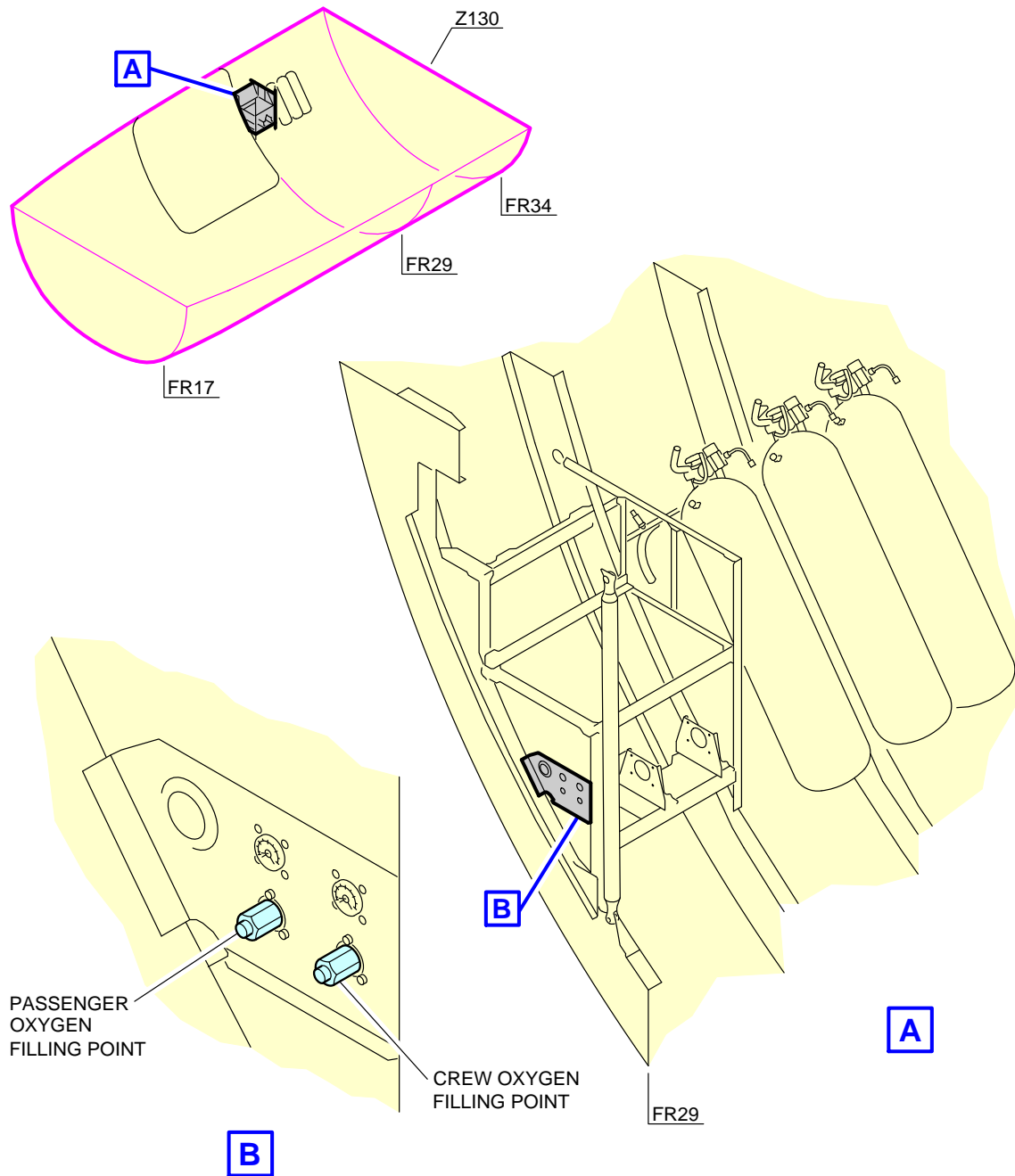

L_AC_050405_1_0020101_01_00

Ground Service Connections
Oxygen System
FIGURE-5-4-5-991-002-A01

5-4-6 Fuel System

****ON A/C A380-800**

Fuel Servicing

1. Refuel/Defuel Control Panel

ACCESS	DISTANCE			
	AFT OF NOSE	FROM AIRCRAFT CENTERLINE		MEAN HEIGHT FROM GROUND
		LH SIDE	RH SIDE	
Refuel/Defuel Control Panel: Access Door 199KB	48 m (157.48 ft)		0.68 m (2.23 ft)	1.98 m (6.50 ft)

2. Refuel/Defuel Connectors

ACCESS	DISTANCE			
	AFT OF NOSE	FROM AIRCRAFT CENTERLINE		MEAN HEIGHT FROM GROUND
		LH SIDE	RH SIDE	
Refuel/Defuel Coupling, Left: Access Door 522GB	31.89 m (104.63 ft)	17.97 m (58.96 ft)		5.94 m (19.49 ft)
Refuel/Defuel Coupling, Right: Access Door 622GB	31.89 m (104.63 ft)		17.97 m (58.96 ft)	5.94 m (19.49 ft)

- A. Refuel/Defuel couplings:
 - Four standard 2.5 in. ISO 45 connections.
- B. Refuel pressure:
 - Maximum pressure: 50 psi (3.45 bar).

3. Overpressure Protector and NACA Flame Arrestor

ACCESS	DISTANCE			
	AFT OF NOSE	FROM AIRCRAFT CENTERLINE		MEAN HEIGHT FROM GROUND
		LH SIDE	RH SIDE	
Overpressure Protector (Wing): Access Panel 550CB (650CB)	46.65 m (153.05 ft)	36.75 m (120.57 ft)	36.75 m (120.57 ft)	7.51 m (24.64 ft)
NACA Flame Arrestor (Wing): Access Panel 550BB (650BB)	46.33 m (152.00 ft)	35.98 m (118.04 ft)	35.98 m (118.04 ft)	7.44 m (24.41 ft)
Overpressure Protector (Trim Tank): Access Panel 344AB	62.75 m (205.87 ft)		5.19 m (17.03 ft)	7.68 m (25.20 ft)
NACA Flame Arrestor (Trim Tank): Access Panel 344AB	63.97 m (209.88 ft)		4.64 m (15.22 ft)	7.55 m (24.77 ft)

****ON A/C A380-800**

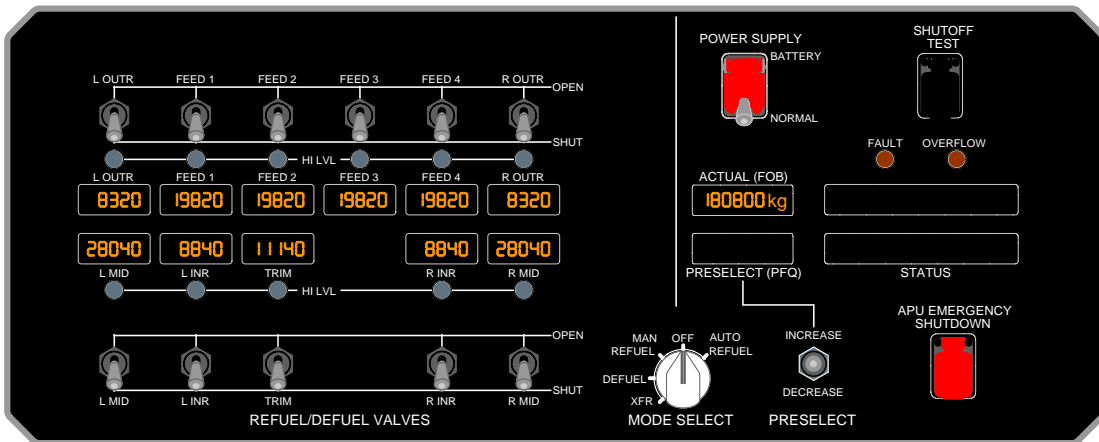
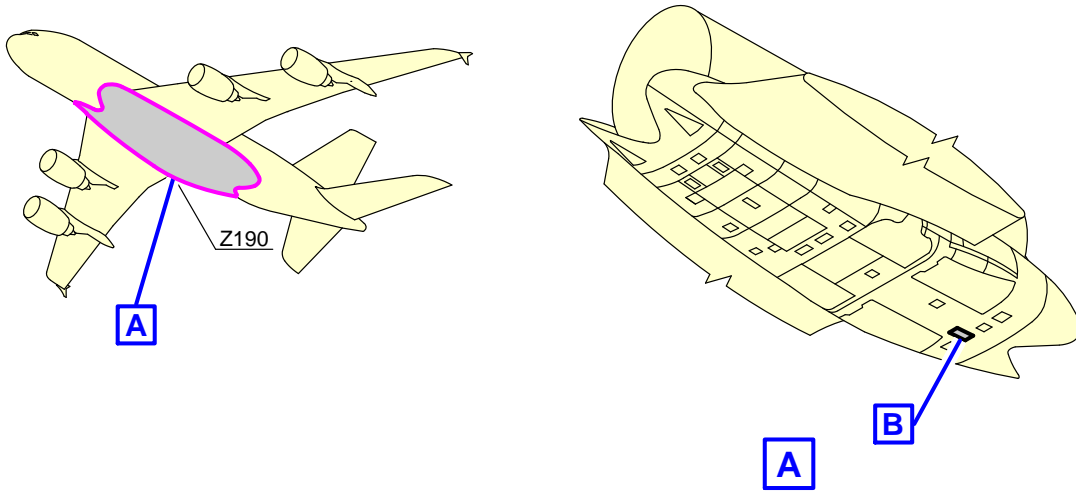

42QU

B

L_AC_050406_1_0010101_01_00

Ground Service Connections
 Refuel/Defuel Control Panel
 FIGURE-5-4-6-991-001-A01

****ON A/C A380-800**

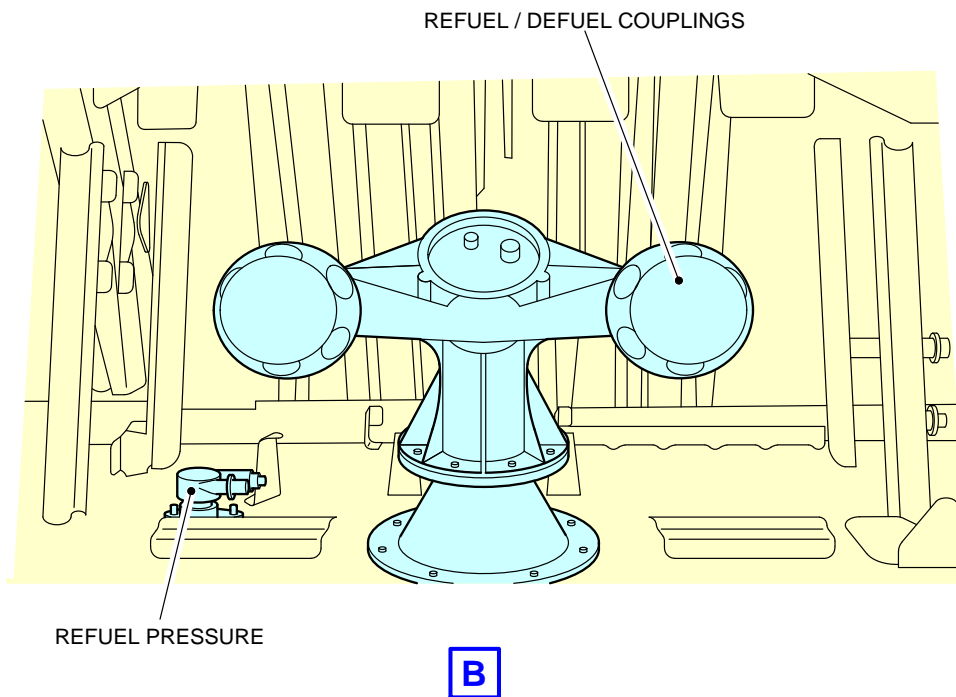
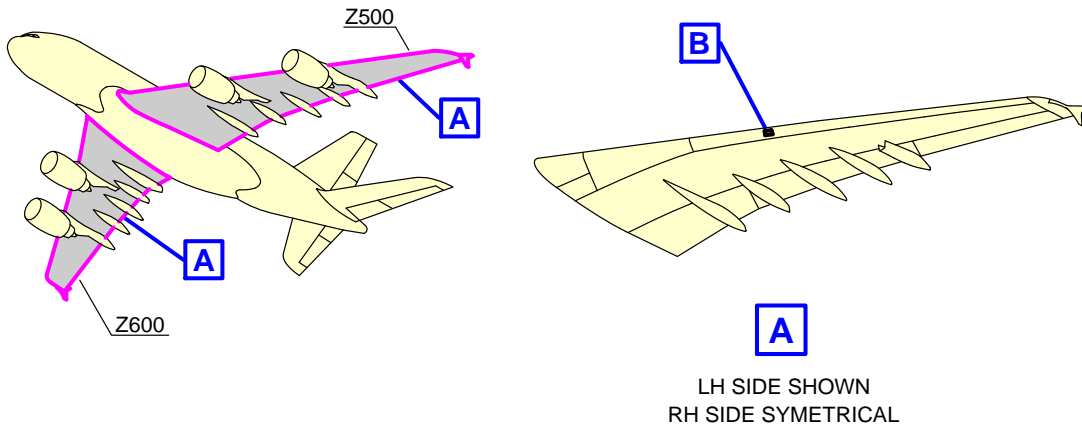

L_AC_050406_1_0020101_01_00

Ground Service Connections
Pressure Refuel Connections
FIGURE-5-4-6-991-002-A01

****ON A/C A380-800**

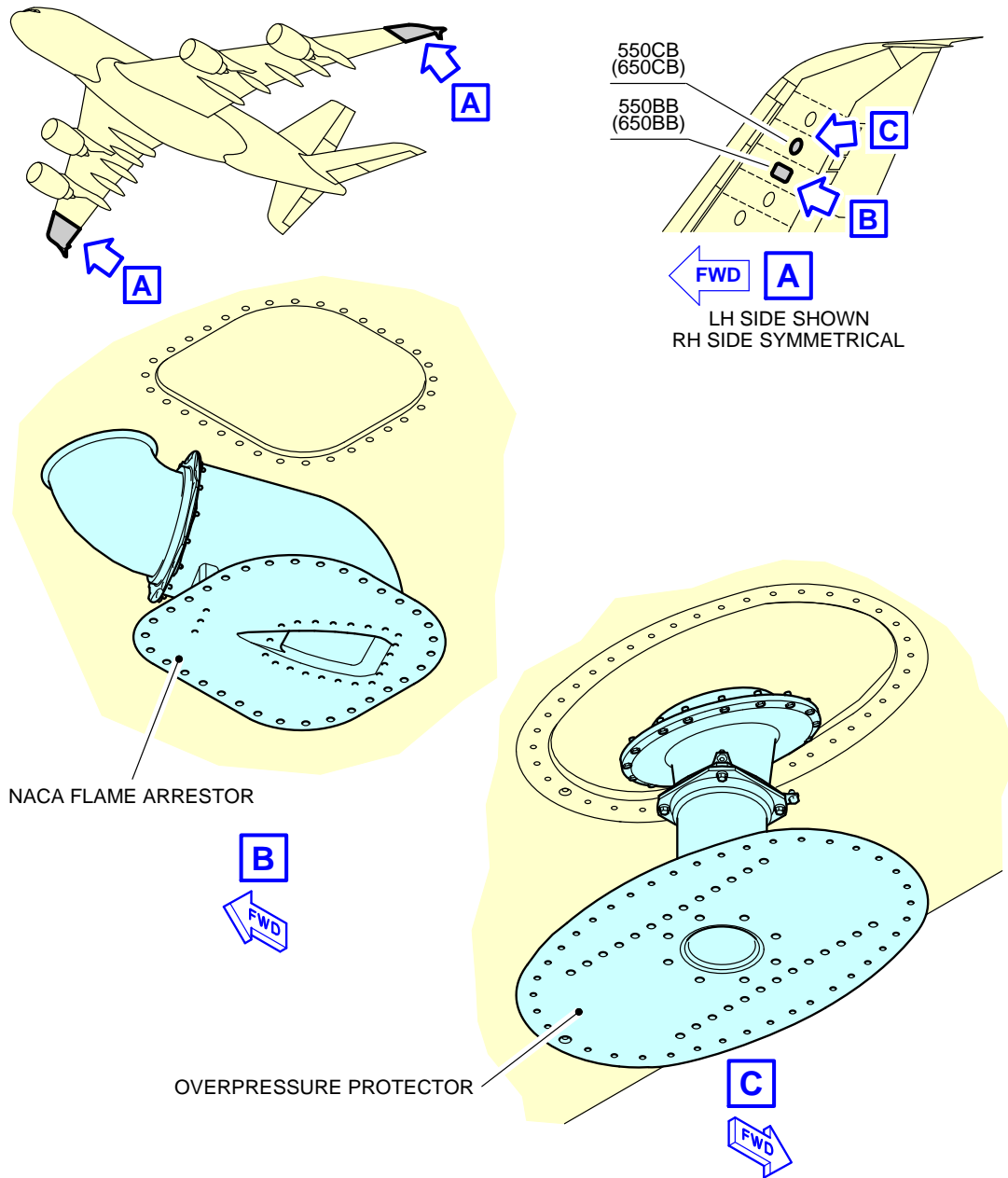

L_AC_050406_1_0030101_01_01

Ground Service Connections
Overpressure Protector and NACA Flame Arrestor - Wing
FIGURE-5-4-6-991-003-A01

****ON A/C A380-800**

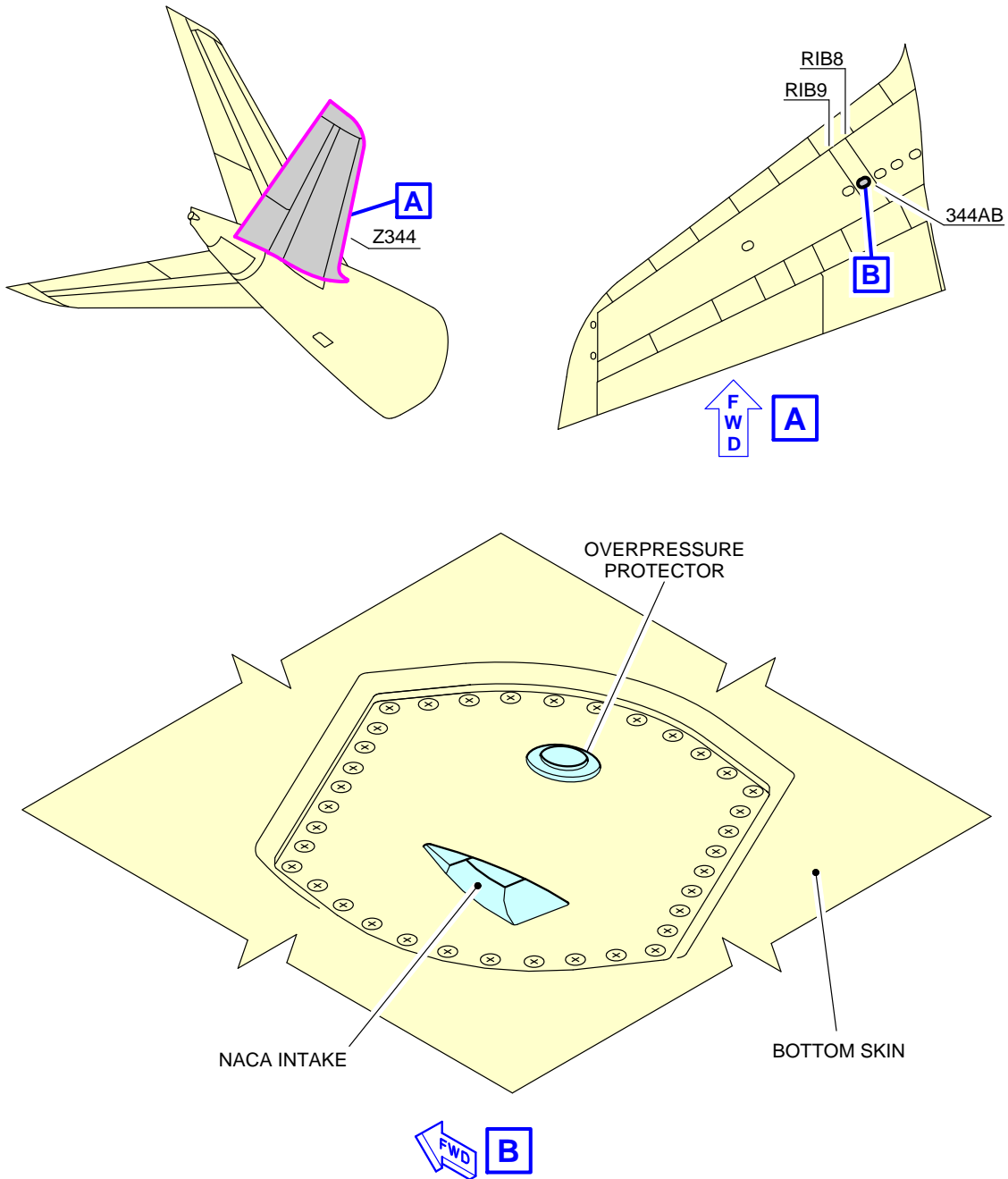

L_AC_050406_1_0040101_01_00

Ground Service Connections
Overpressure Protector and NACA Flame Arrester - Trim Tank
FIGURE-5-4-6-991-004-A01

5-4-7 Pneumatic System

****ON A/C A380-800**

Pneumatic Servicing

1. Low Pressure Connectors

ACCESS	DISTANCE			MEAN HEIGHT FROM GROUND
	AFT OF NOSE	FROM AIRCRAFT CENTERLINE		
		LH SIDE	RH SIDE	
Access Door 191GB	21.85 m (71.69 ft)	1.24 m (4.07 ft)		2.08 m (6.82 ft)
Access Door 191JB	22.36 m (73.36 ft)	1.76 m (5.77 ft)		2.08 m (6.82 ft)
Access Door 191HB	21.85 m (71.69 ft)		1.24 m (4.07 ft)	2.08 m (6.82 ft)
Access Door 191KB	22.36 m (73.36 ft)		1.76 m (5.77 ft)	2.08 m (6.82 ft)

A. Connectors:

- (1) Four standard 8 in. SAE AS4262 type B connections.

2. High Pressure Connectors

ACCESS	DISTANCE			MEAN HEIGHT FROM GROUND
	AFT OF NOSE	FROM AIRCRAFT CENTERLINE		
		LH SIDE	RH SIDE	
Access Door 193BB	25.37 m (83.23 ft)	0.2 m (0.66 ft)		1.78 m (5.84 ft)

A. Connectors:

- (1) Three standard 3 in. ISO 2026 connections.

****ON A/C A380-800**

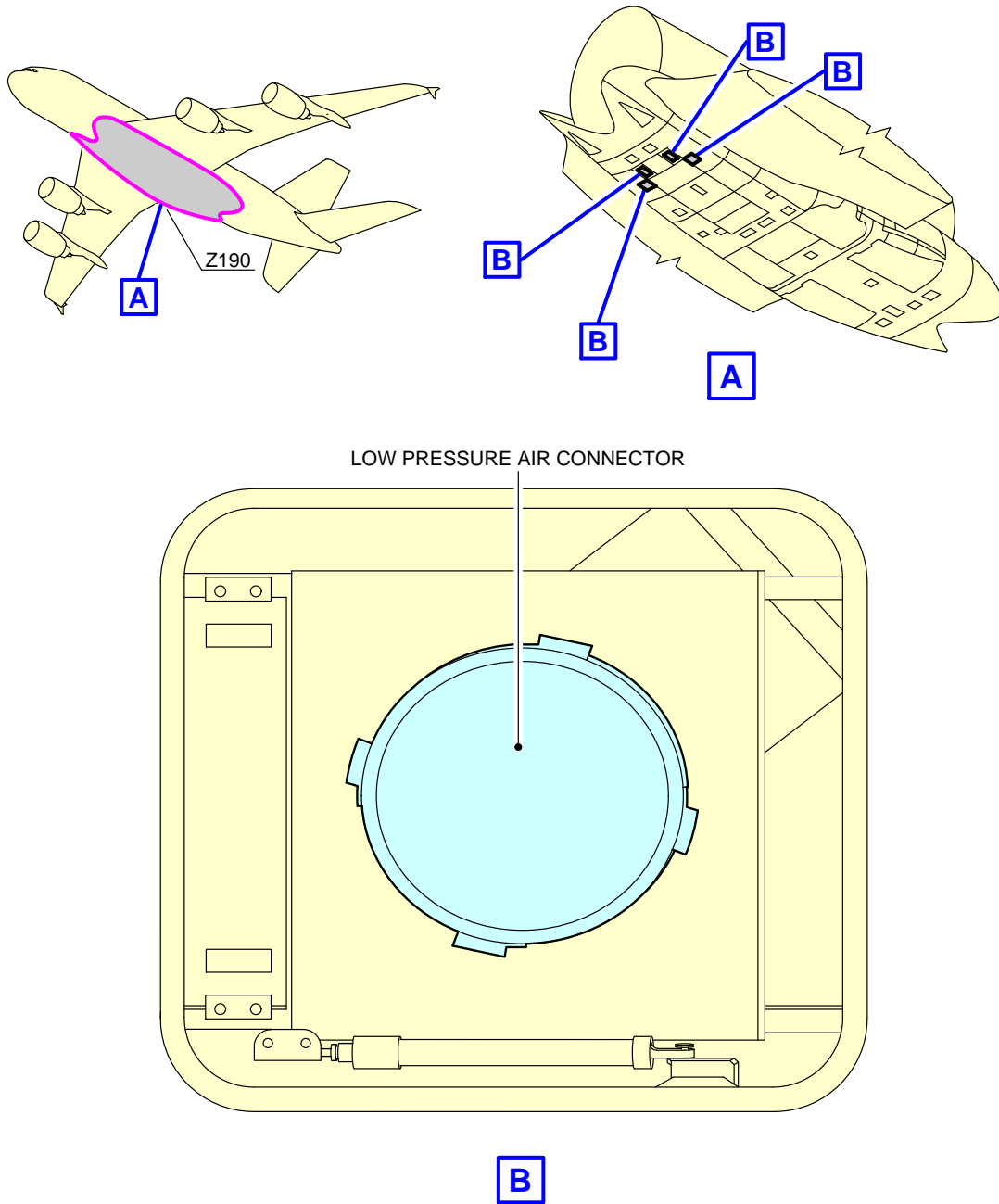

L_AC_050407_1_0010101_01_00

Ground Service Connections
Low Pressure Preconditioned Air
FIGURE-5-4-7-991-001-A01

****ON A/C A380-800**

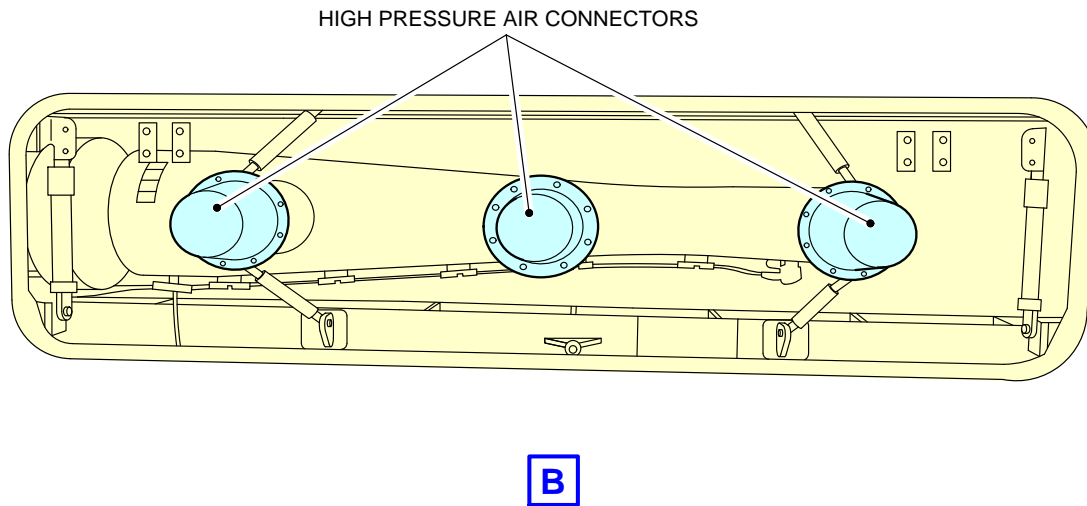
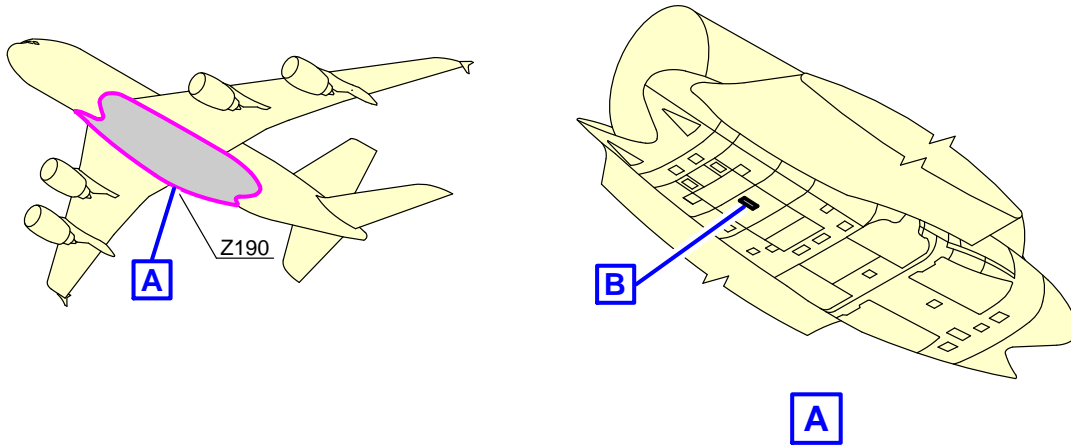

L_AC_050407_1_0020101_01_00

Ground Service Connections
High Pressure Preconditioned Air
FIGURE-5-4-7-991-002-A01

5-4-8 Oil System

****ON A/C A380-800**

Oil Servicing

1. RR TRENT 900 Engines

A. Engine Oil Servicing

ACCESS	DISTANCE			
	AFT OF NOSE	FROM AIRCRAFT CENTERLINE		MEAN HEIGHT FROM GROUND
		LH SIDE	RH SIDE	
Engine 1: Access Door 416BR	32.65 m (107.12 ft)	23.58 m (77.36 ft)		4.24 m (13.91 ft)
Engine 2: Access Door 426BR	24.98 m (81.96 ft)	12.74 m (41.80 ft)		3.08 m (10.10 ft)
Engine 3: Access Door 436BR	24.98 m (81.96 ft)		16.61 m (54.49 ft)	3.08 m (10.10 ft)
Engine 4: Access Door 446BR	32.65 m (107.12 ft)		27.45 m (90.06 ft)	4.24 m (13.91 ft)

B. VFG Oil Servicing

ACCESS	DISTANCE			
	AFT OF NOSE	FROM AIRCRAFT CENTERLINE		MEAN HEIGHT FROM GROUND
		LH SIDE	RH SIDE	
Engine 1: Access Door 415AL	33.17 m (108.83 ft)	26.14 m (85.76 ft)		2.56 m (8.40 ft)
Engine 2: Access Door 425AL	25.57 m (83.89 ft)	15.31 m (50.23 ft)		1.33 m (4.36 ft)
Engine 3: Access Door 435AL	25.57 m (83.89 ft)		13.93 m (45.70 ft)	1.33 m (4.36 ft)
Engine 4: Access Door 445AL	33.17 m (108.83 ft)		24.90 m (81.69 ft)	2.56 m (8.40 ft)

(1) For VFG oil servicing, open:

- Left Fan Exhaust Cowl.

C. Starter Oil Servicing

ACCESS	DISTANCE			
	AFT OF NOSE	FROM AIRCRAFT CENTERLINE		MEAN HEIGHT FROM GROUND
		LH SIDE	RH SIDE	
Engine 1: Access Door 415AL and 416AR	39.78 m (130.51 ft)	25.78 m (84.58 ft)		2.59 m (8.49 ft)
Engine 2: Access Door 425AL and 426AR	32.15 m (105.49 ft)	14.94 m (49.02 ft)		1.39 m (4.56 ft)
Engine 3: Access Door 435AL and 436AR	32.15 m (105.48 ft)		14.42 m (47.31 ft)	1.39 m (4.56 ft)
Engine 4: Access Door 445AL and 446AR	39.78 m (130.51 ft)		25.25 m (82.84 ft)	2.59 m (8.49 ft)

(1) For access to Starter Oil Servicing, open Fan Cowl.

2. GP7200 Engines

A. Engine Oil Servicing

ACCESS	DISTANCE			
	AFT OF NOSE	FROM AIRCRAFT CENTERLINE		MEAN HEIGHT FROM GROUND
		LH SIDE	RH SIDE	
Engine 1: Access Door 415CL	33.03 m (108.37 ft)	27.42 m (89.96 ft)		4.40 m (14.44 ft)
Engine 2: Access Door 425CL	25.35 m (83.17 ft)	16.62 m (54.53 ft)		3.13 m (10.27 ft)
Engine 3: Access Door 435CL	25.35 m (83.17 ft)		12.78 m (41.93 ft)	3.13 m (10.27 ft)
Engine 4: Access Door 445CL	33.03 m (108.37 ft)		23.62 m (77.49 ft)	4.40 m (14.44 ft)

B. VFG Oil Servicing

ACCESS	DISTANCE			
	AFT OF NOSE	FROM AIRCRAFT CENTERLINE		MEAN HEIGHT FROM GROUND
		LH SIDE	RH SIDE	
Engine 1: Access Door 415AL and 417AL	34.49 m (113.16 ft)	25.43 m (83.43 ft)		2.63 m (8.63 ft)
Engine 2: Access Door 425AL and 427AL	26.81 m (87.96 ft)	14.63 m (48.00 ft)		1.36 m (4.46 ft)
Engine 3: Access Door 435AL and 437AL	26.81 m (87.96 ft)		14.63 m (48.00 ft)	1.36 m (4.46 ft)
Engine 4: Access Door 445AL and 447AL	34.49 m (113.16 ft)		25.43 m (83.43 ft)	2.63 m (8.63 ft)

- (1) For VFG oil servicing, open:
- Left Fan Exhaust Cowl
 - Left Thrust Reverser Cowl.

C. Starter Oil Servicing

ACCESS	DISTANCE			
	AFT OF NOSE	FROM AIRCRAFT CENTERLINE		MEAN HEIGHT FROM GROUND
		LH SIDE	RH SIDE	
Engine 1: Access Door 415AL and 416AR	40.42 m (132.61 ft)	27.34 m (89.70 ft)		3.35 m (10.99 ft)
Engine 2: Access Door 425AL and 426AR	32.74 m (107.41 ft)	16.55 m (54.30 ft)		2.47 m (8.10 ft)
Engine 3: Access Door 435AL and 436AR	32.74 m (107.41 ft)		12.71 m (41.70 ft)	2.47 m (8.10 ft)
Engine 4: Access Door 445AL and 446AR	40.42 m (132.61 ft)		23.53 m (77.20 ft)	3.35 m (10.99 ft)

- (1) For access to Starter Oil Servicing, open Fan Cowl.

3. APU Oil Servicing

ACCESS	DISTANCE			
	AFT OF NOSE	FROM AIRCRAFT CENTERLINE		MEAN HEIGHT FROM GROUND
		LH SIDE	RH SIDE	
Access Doors: 315AL and 315AR	67.55 m (221.62 ft)	0.44 m (1.44 ft)		6.83 m (22.41 ft)

- A. Capacity:
- 18.13 l (4.79 US gal).

****ON A/C A380-800**

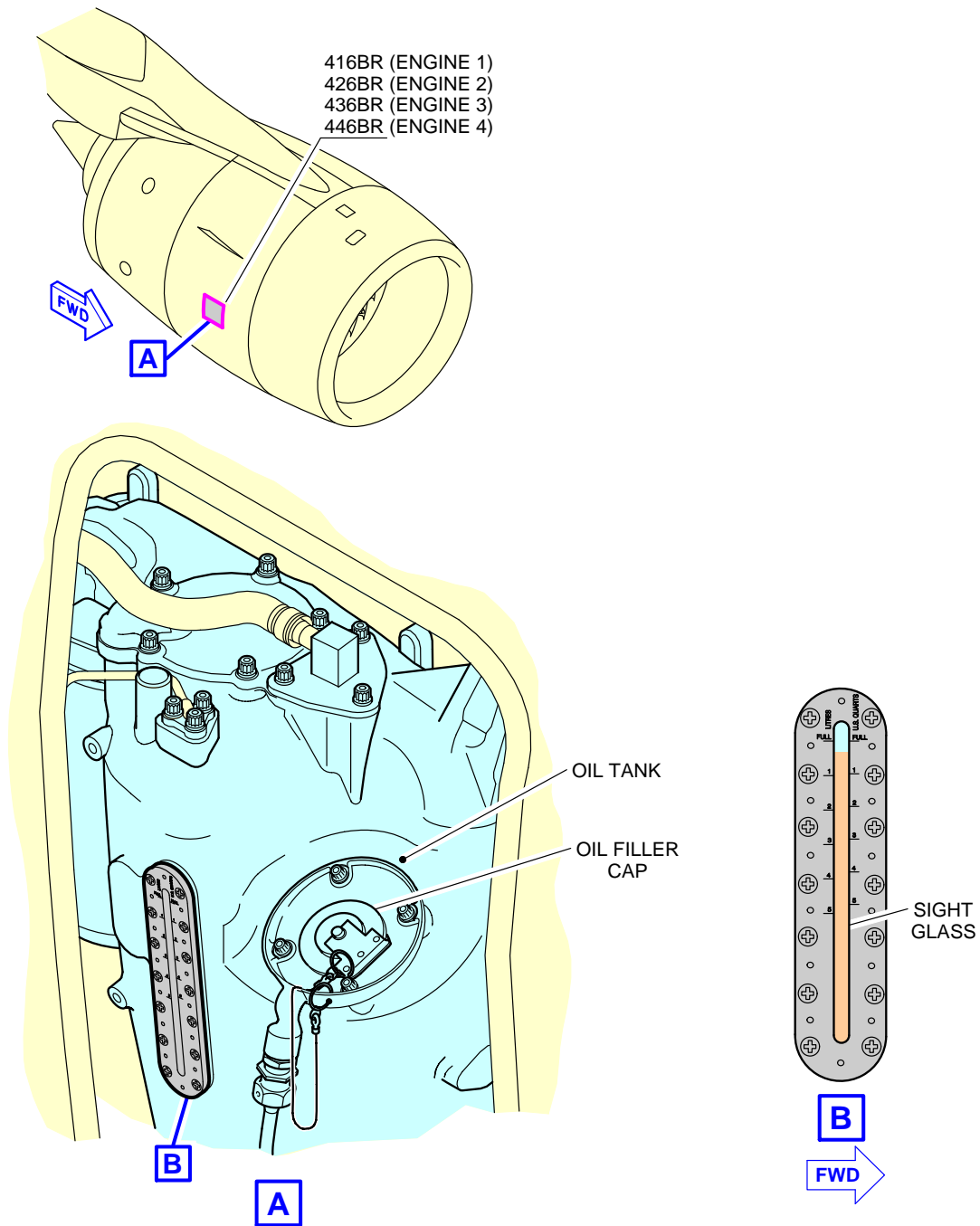

L_AC_050408_1_0060101_01_01

Ground Service Connections
Engine Oil Servicing - TRENT 900 Engines
FIGURE-5-4-8-991-006-A01

****ON A/C A380-800**

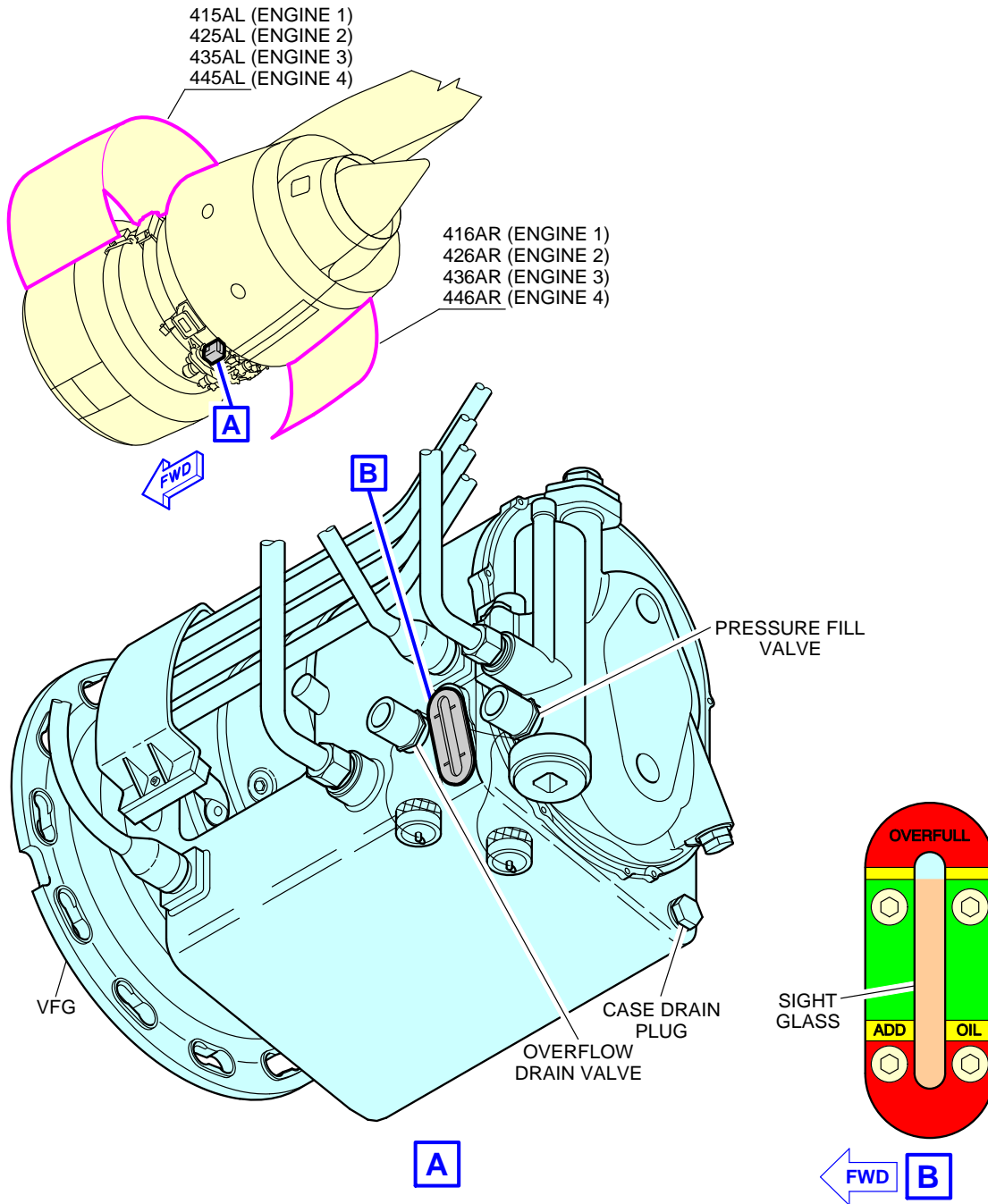

L_AC_050408_1_0070101_01_01

Ground Service Connections
VFG Oil Servicing - TRENT 900 Engines
FIGURE-5-4-8-991-007-A01

****ON A/C A380-800**

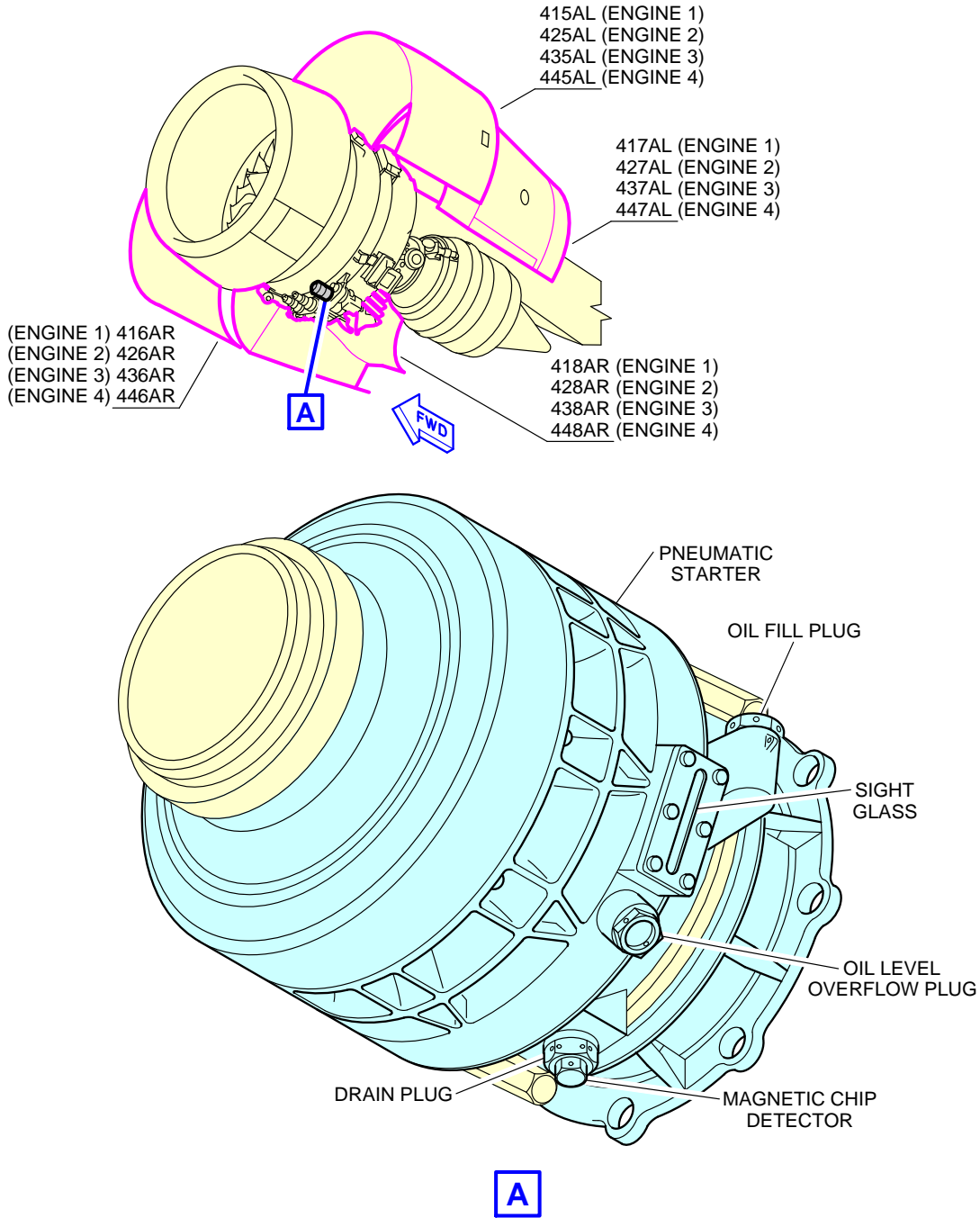

L_AC_050408_1_0130101_01_00

Ground Service Connections
Starter Oil Servicing - TRENT 900 Engines
FIGURE-5-4-8-991-013-A01

****ON A/C A380-800**

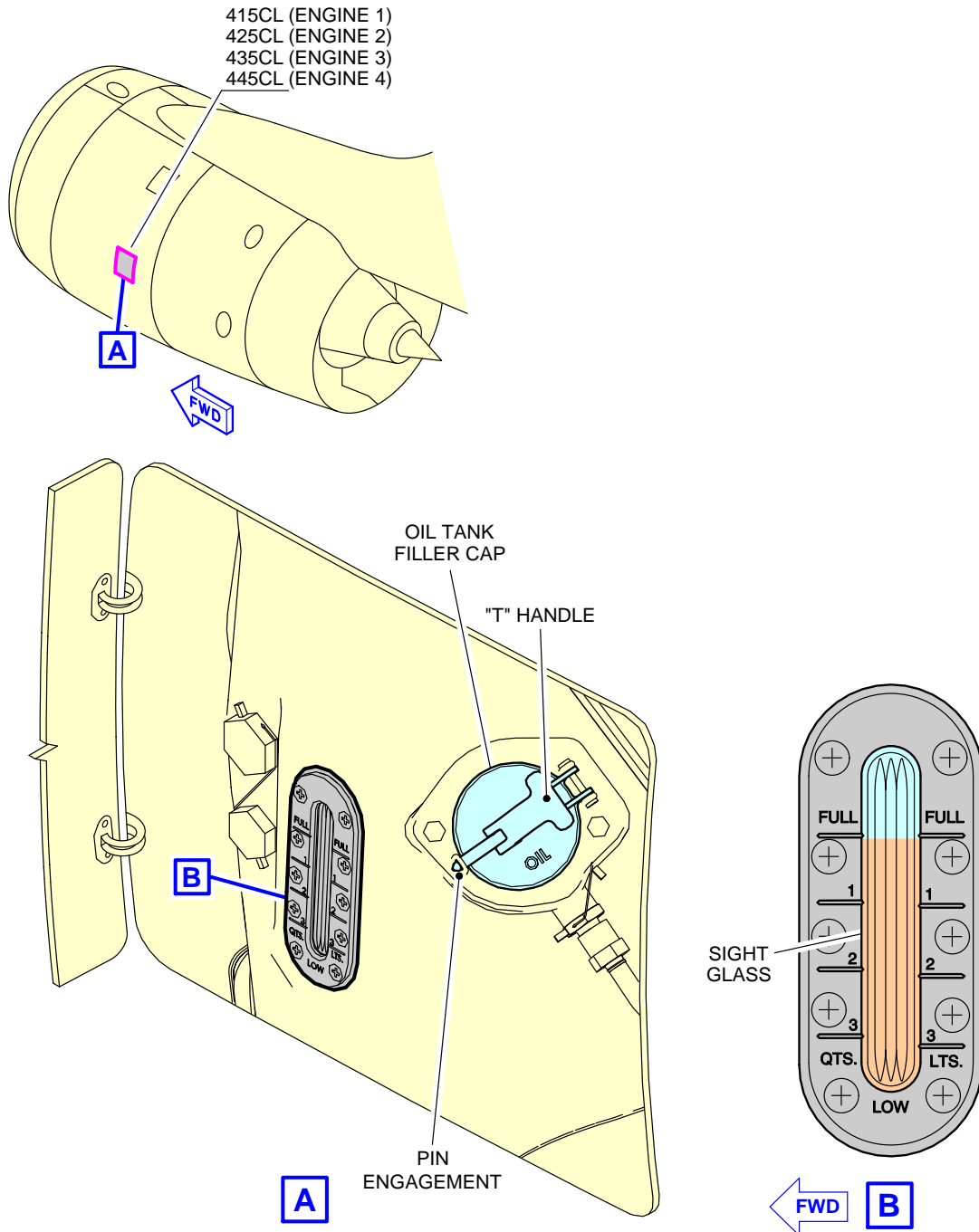

L_AC_050408_1_0140101_01_00

Ground Service Connections
Engine Oil Servicing - GP7200 Engines
FIGURE-5-4-8-991-014-A01

****ON A/C A380-800**

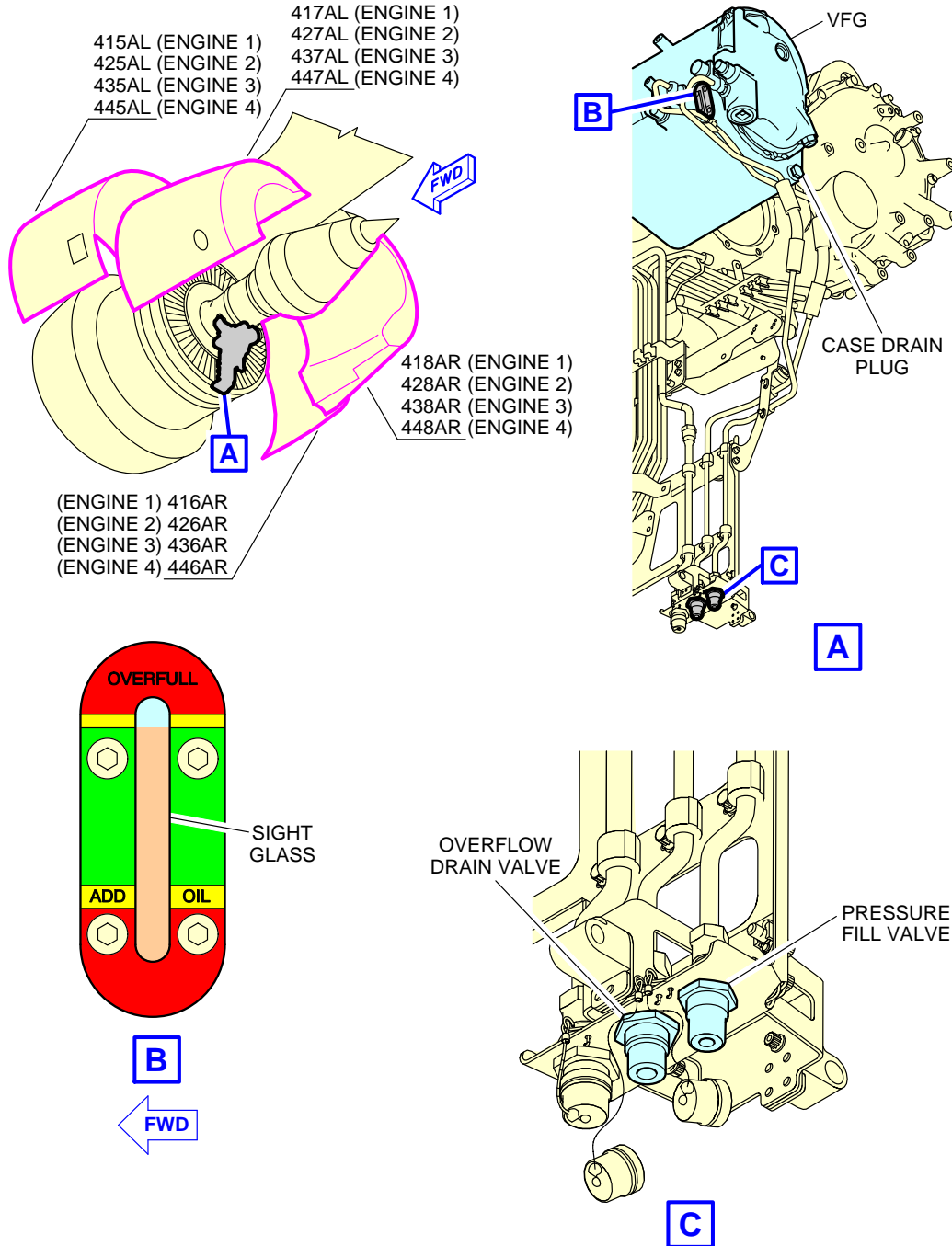

L_AC_050408_1_0150101_01_00

Ground Service Connections
VFG Oil Servicing - GP7200 Engines
FIGURE-5-4-8-991-015-A01

****ON A/C A380-800**

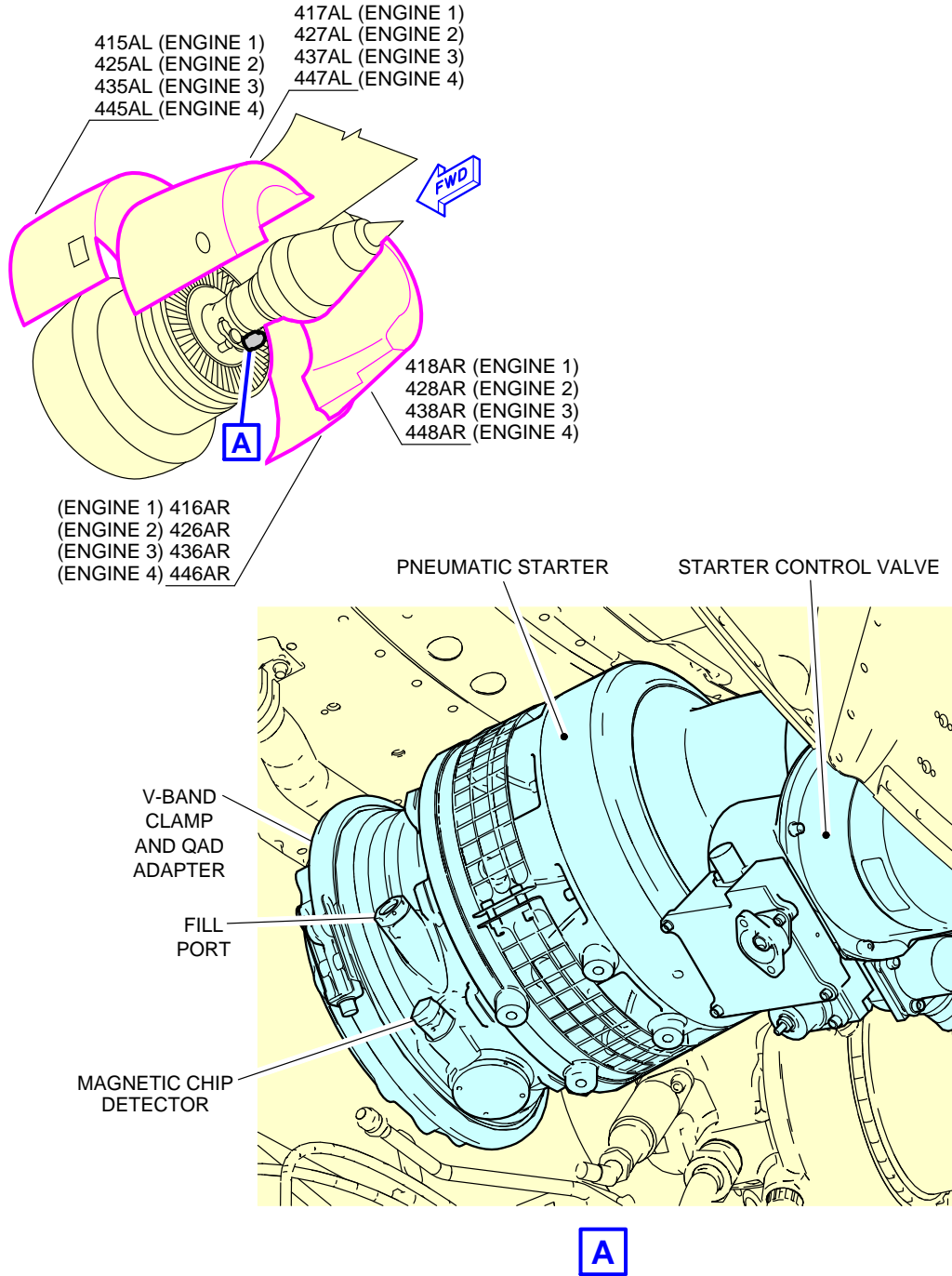

L_AC_050408_1_0160101_01_00

Ground Service Connections
Starter Oil Servicing - GP7200 Engines
FIGURE-5-4-8-991-016-A01

****ON A/C A380-800**

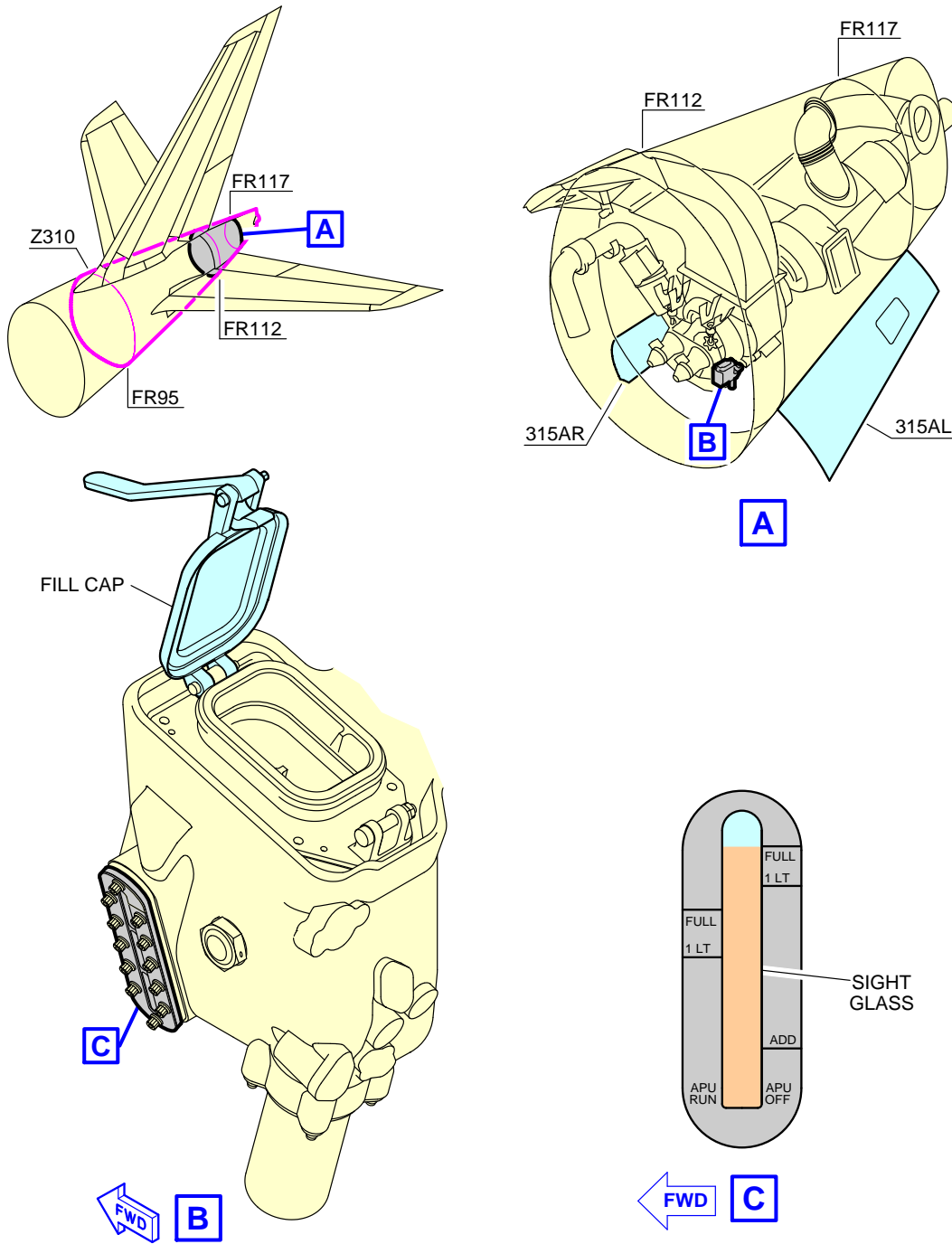

L_AC_050408_1_0170101_01_00

Ground Service Connections
 APU Oil Servicing
 FIGURE-5-4-8-991-017-A01

5-4-9 Potable Water System

****ON A/C A380-800**

Potable Water Servicing

1. Potable Water Servicing

This section provides data related to the location of the ground service connections.

ACCESS	DISTANCE			
	AFT OF NOSE	FROM AIRCRAFT CENTERLINE		MEAN HEIGHT FROM GROUND
		LH SIDE	RH SIDE	
Potable Water Ground Service Panel: Access Door 199NB	43.67 m (143.27 ft)		0.37 m (1.21 ft)	2.13 m (6.99 ft)
Potable Water Drain Panel: Access Door 133BL	9.83 m (32.25 ft)		0.30 m (0.98 ft)	2.74 m (8.99 ft)

NOTE : Distances are approximate.

A. Connections

Fill and drain port - ISO 17775, 3/4 in.

B. Capacity:

(1) Total Capacity

- Standard configuration (six tanks): 1 700 l (449 US gal)
- Optional configuration (seven tanks): 1 998 l (528 US gal)
- Optional configuration (eight tanks): 2 267 l (599 US gal).

C. Filling Pressure:

- (1) Max Filling Pressure: 8.6 bar (125 psi).

****ON A/C A380-800**

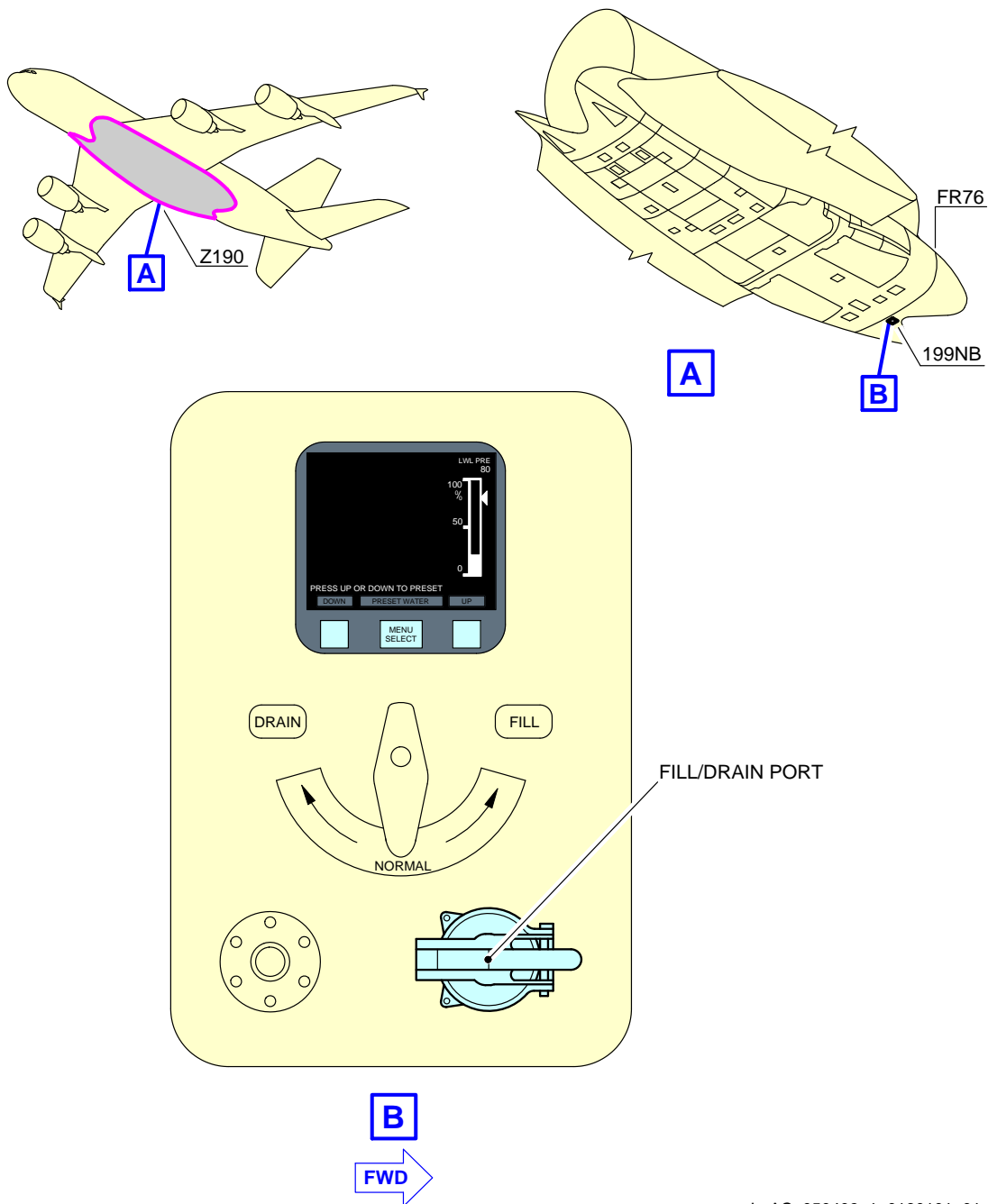

L_AC_050409_1_0160101_01_00

Ground Service Connections
Potable Water Ground Service Panel
FIGURE-5-4-9-991-016-A01

****ON A/C A380-800**

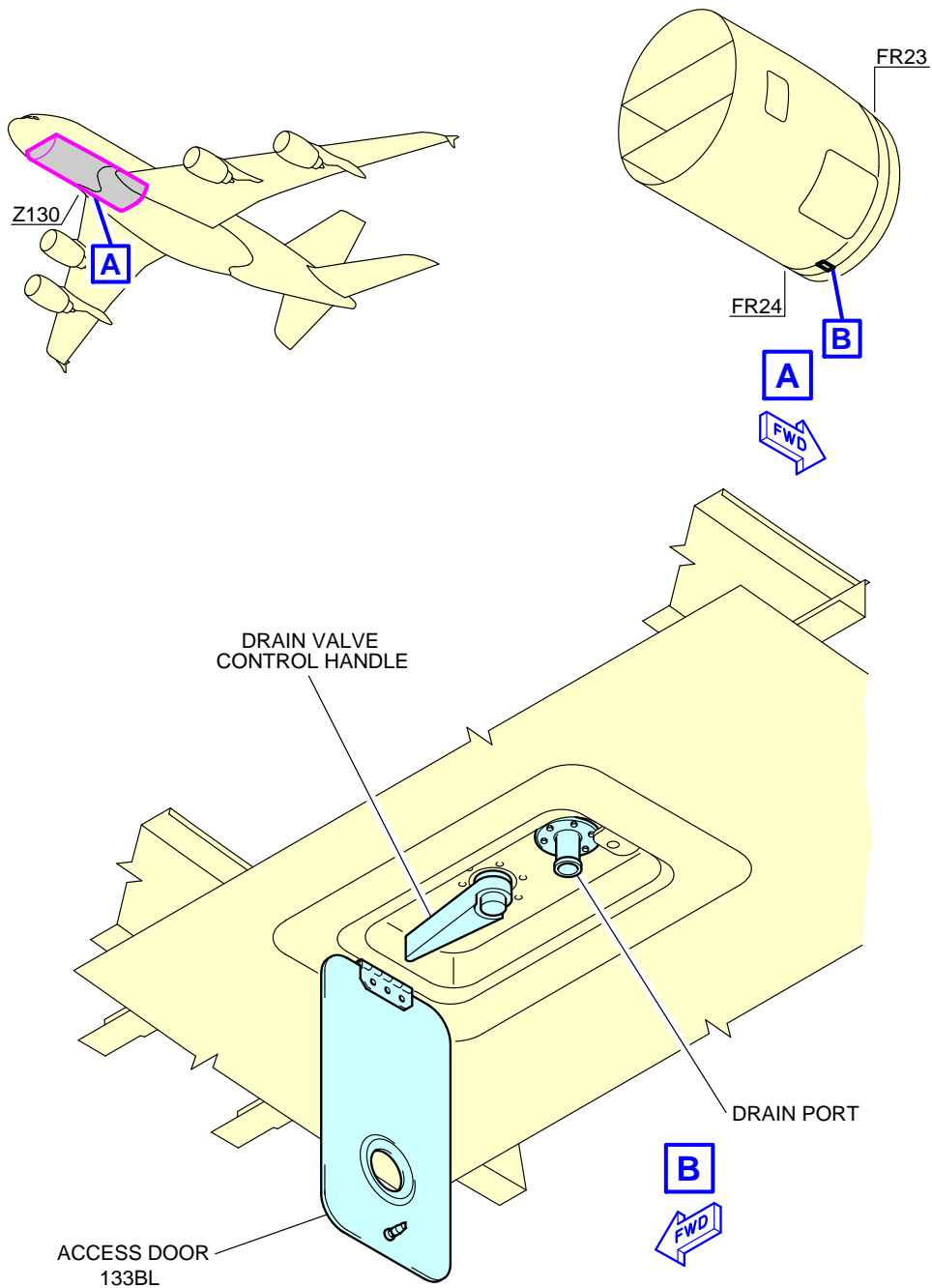

L_AC_050409_1_0170101_01_00

Ground Service Connections
Potable Water Drain Panel
FIGURE-5-4-9-991-017-A01

****ON A/C A380-800**

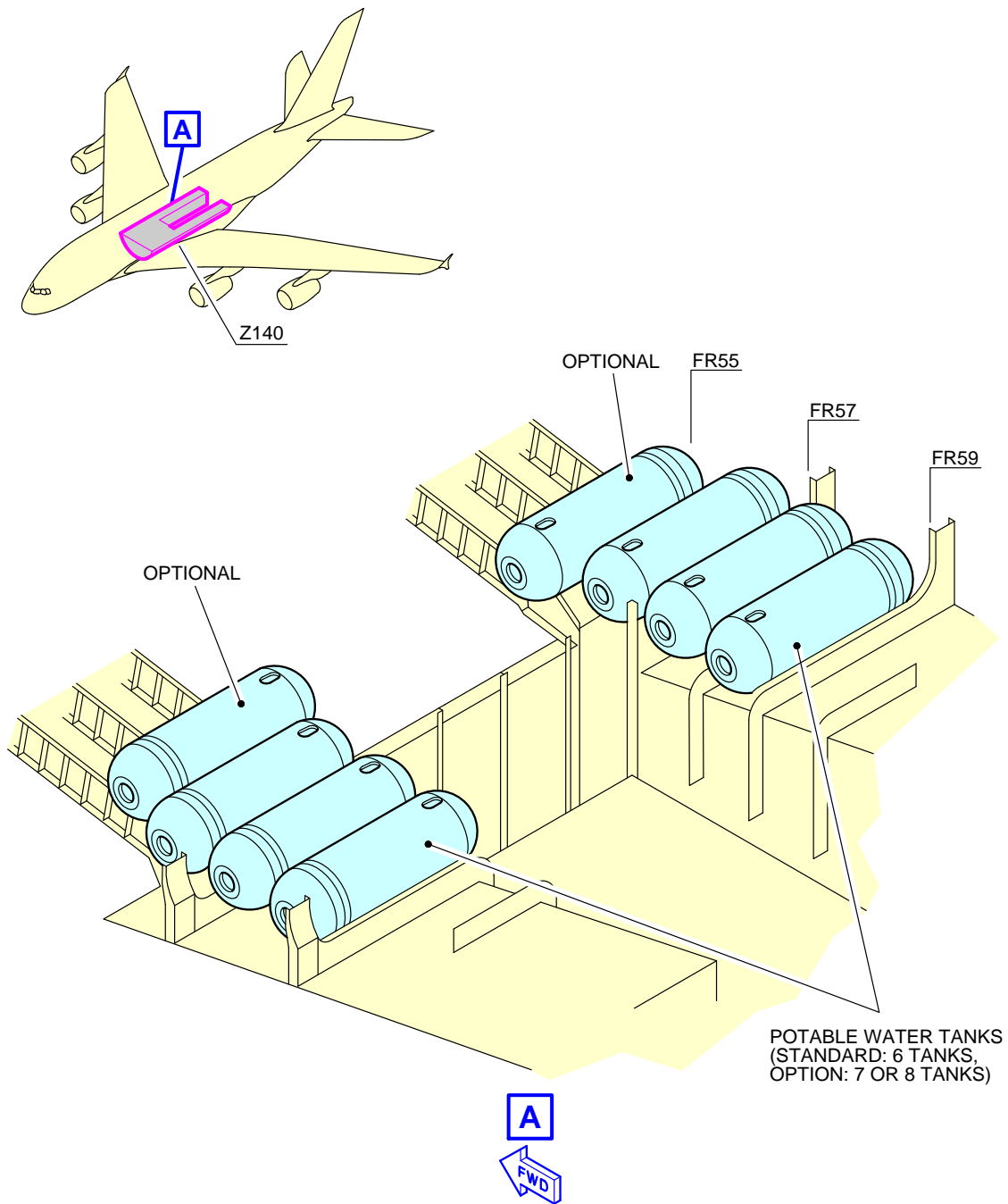

L_AC_050409_1_0180101_01_00

Ground Service Connections
Potable Water Tanks Location
FIGURE-5-4-9-991-018-A01

5-4-10 Waste Water System

****ON A/C A380-800**

Waste Water System

1. Waste Water System

This section provides data related to the location of the ground service connections.

ACCESS	DISTANCES			
	AFT OF NOSE	FROM AIRCRAFT CENTERLINE		MEAN HEIGHT FROM GROUND
		LH SIDE	RH SIDE	
Waste Water Ground Service Panel: Access door 171AL	53.31 m (174.90 ft)	0.26 m (0.85 ft)		3.40 m (11.15 ft)

NOTE : Distances are approximate.

2. Technical Specifications

A. Connectors

- (1) Waste water drain-connection - ISO 17775, 4 in.
- (2) Waste water rinse/fill port - ISO 17775, 1 in.

B. Capacity

There are four waste tanks, two upper deck tanks and two main deck tanks, see FIGURE 5-4-10-991-003-A.

- (1) Upper Deck Waste Tanks
 - Two tanks (373 l (99 US gal) each).
 - Each tank is precharged with 35 l (9 US gal) of chemical fluid.
- (2) Main Deck Waste Tanks
 - Two tanks (675 l (178 US gal) each).
 - Each tank is precharged with 35 l (9 US gal) of chemical fluid.
- (3) Total Waste Tank Capacity
 - 2096 l (554 US gal).

C. Pressure

Maximum pressure for rinsing and precharge to the rinse/fill port is 3.45 bar (50 psi).

****ON A/C A380-800**

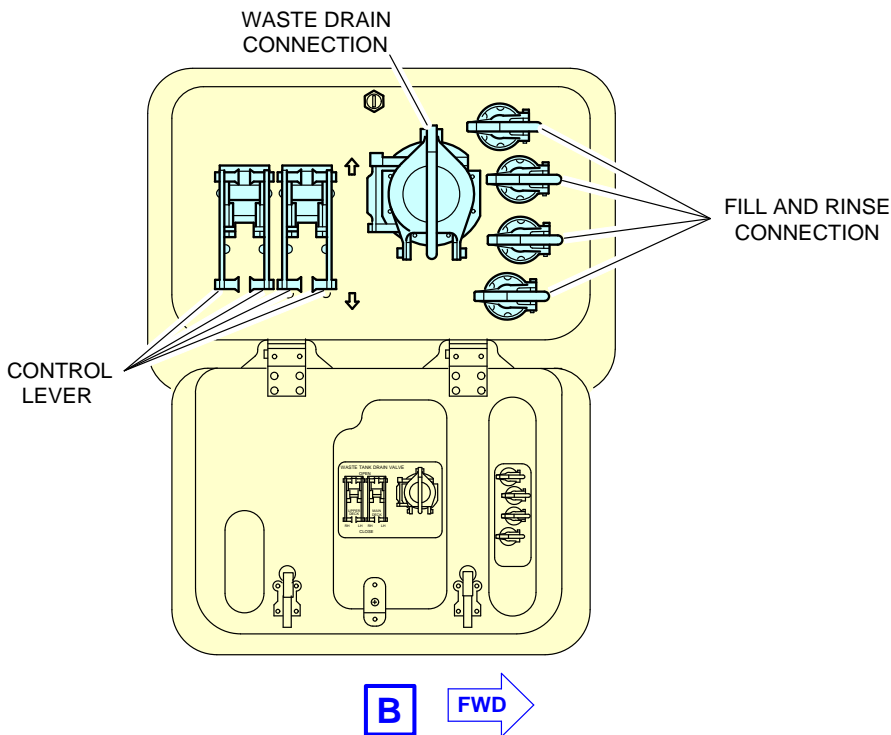
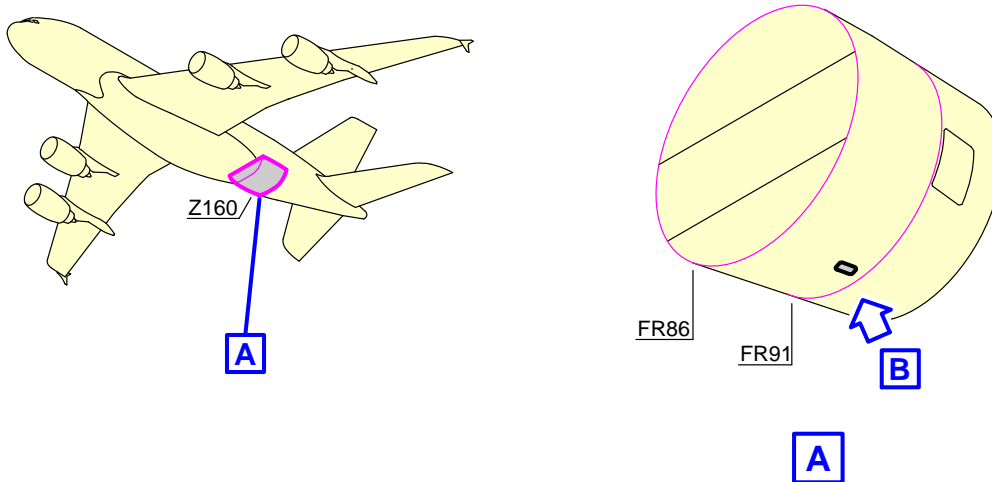

L_AC_050410_1_0010101_01_00

Ground Service Connections
Waste Water Ground Service Panel
FIGURE-5-4-10-991-001-A01

****ON A/C A380-800**

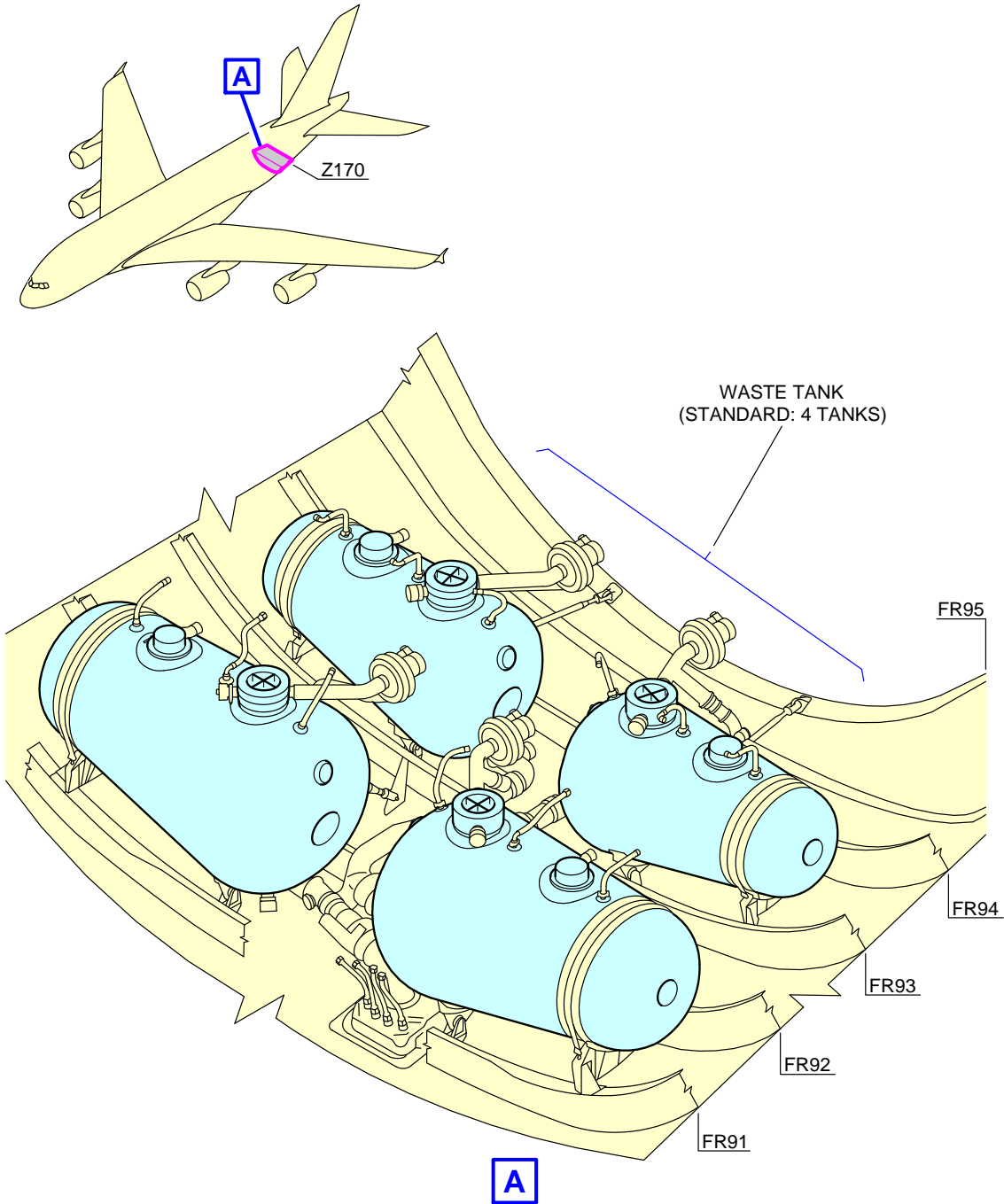

L_AC_050410_1_0030101_01_01

Ground Service Connections
Waste Tanks Location
FIGURE-5-4-10-991-003-A01

5-4-11 Cargo Control Panels

****ON A/C A380-800**

Cargo Control Panels

1. Cargo Control Panels

ACCESS	DISTANCE			
	AFT OF NOSE	FROM AIRCRAFT CENTERLINE		MEAN HEIGHT FROM GROUND
		LH SIDE	RH SIDE	
FWD CLS* Panel: Access Door 132AR	9.83 m (32.25 ft)		3.08 m (10.10 ft)	4.40 m (14.44 ft)
FWD Cargo Door Panel: Access Door 132BR	9.85 m (32.32 ft)		2.42 m (7.94 ft)	3.40 m (11.15 ft)
AFT CLS* Panel: Access Door 152AR	46.32 m (151.97 ft)		3.11 m (10.20 ft)	4.38 m (14.37 ft)
AFT Cargo Door Panel: Access Door 199DR	45.67 m (149.84 ft)		2.45 m (8.04 ft)	3.08 m (10.10 ft)

NOTE : * CLS - CARGO LOADING SYSTEMS

****ON A/C A380-800**

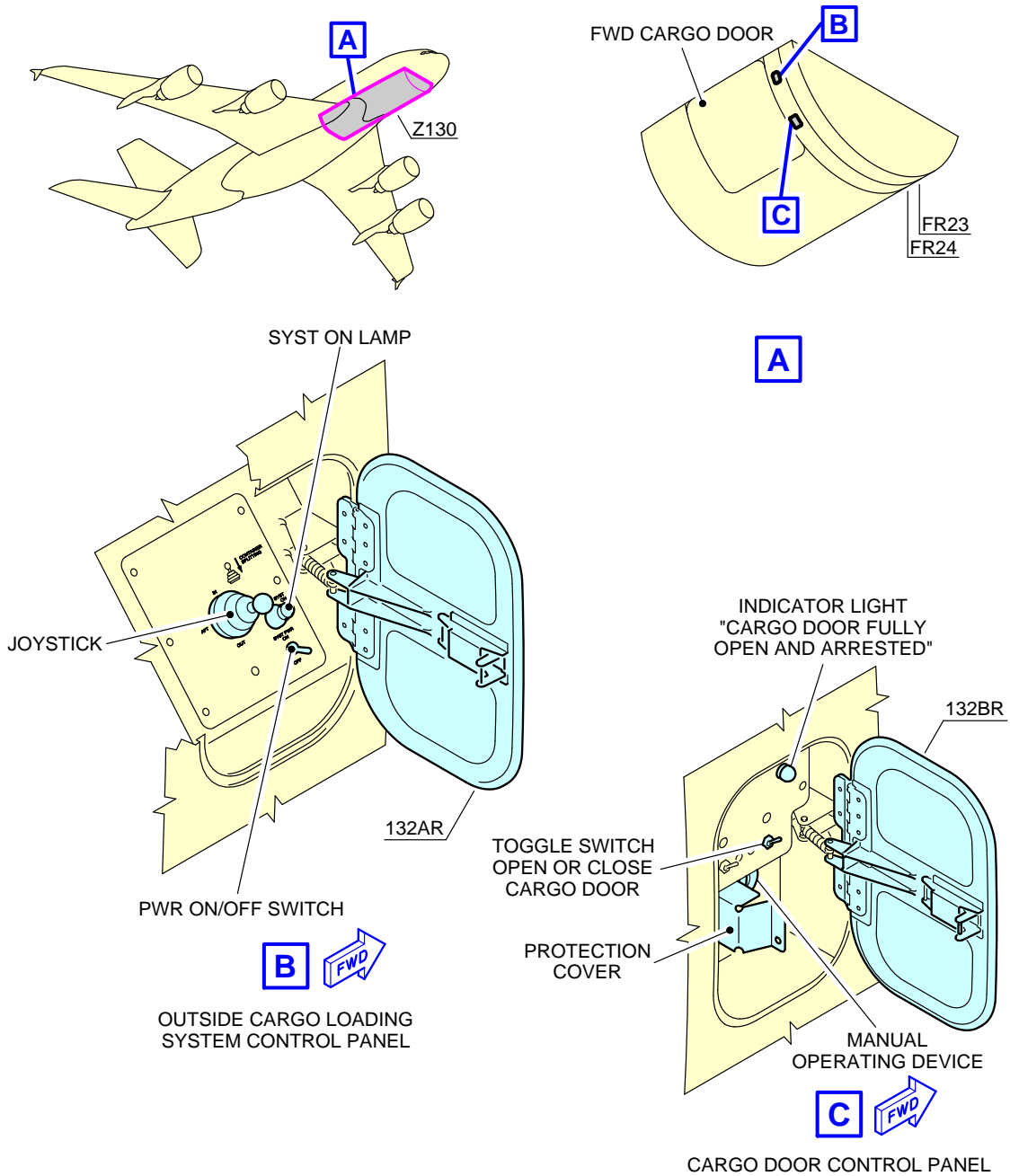

L_AC_050411_1_0010101_01_00

Forward Cargo Control Panels
FIGURE-5-4-11-991-001-A01

****ON A/C A380-800**

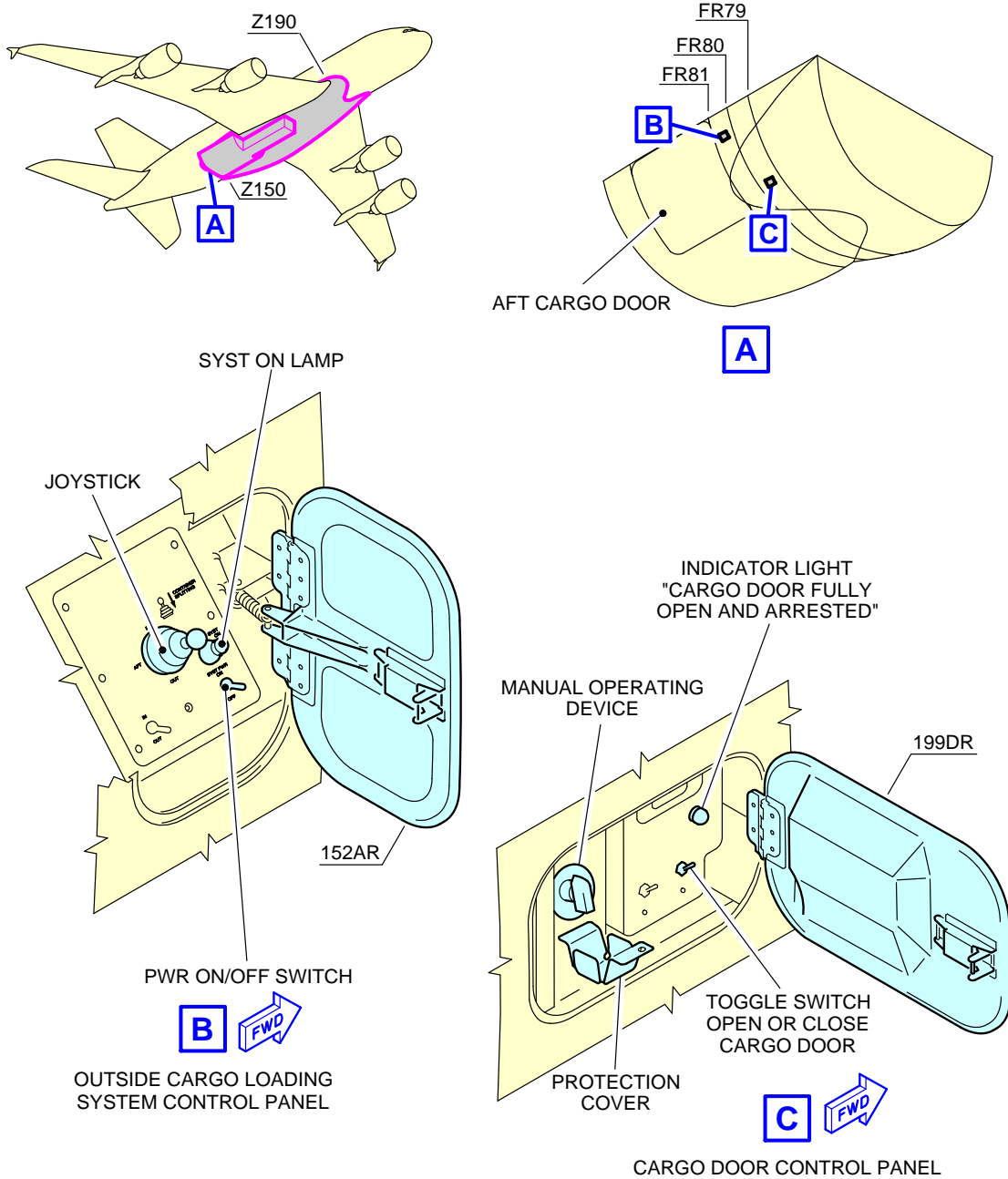

L_AC_050411_1_0020101_01_00

Aft Cargo Control Panels
 FIGURE-5-4-11-991-002-A01

5-5-0 Engine Starting Pneumatic Requirements

****ON A/C A380-800**

Engine Starting Pneumatic Requirements

1. The purpose of this section gives the minimum air data requirements at the aircraft.

ABBREVIATION	DEFINITION
ASU	Air Start Unit
HPGC	High Pressure Ground Connection
OAT	Outside Air Temperature

- A. The pressure at HPGC must not be more than 60 psig (75 psia) and less than 33 psig (48 psia). The temperature must be less than 255 °C (491 °F).
- B. The recommended pressure at HPGC is 40 psig (55 psia).
- C. The OAT and the ASU performances (see the technical data from the ASU manufacturer) effect the ASU output temperature.
- D. The tables provide the global requirements for the airflow start for one engine. If necessary, connect two ASUs in parallel which gives the same pressure (one for each HPGC) to supply the necessary airflow to the aircraft.
- E. In the altitude, the ASU is less efficient but the pressure at HPGC must stay near 40 psig (55 psia).

2. EA GP 7200 Engines for an OAT between -40 °C (-40 °F) and 55 °C (131 °F) at Sea Level

ASU OUTPUT TEMPERATURE RANGE	PRESSURE AT HPGC	MASS FLOW AT HPGC
100 °C (212 °F) - 130 °C (266 °F)	40 psig (55 psia)	284 ppm (129 kg/min)
130 °C (266 °F) - 165 °C (329 °F)	40 psig (55 psia)	273 ppm (124 kg/min)
165 °C (329 °F) - 210 °C (410 °F)	40 psig (55 psia)	262 ppm (119 kg/min)
210 °C (410 °F) - 255 °C (491 °F)	40 psig (55 psia)	249 ppm (113 kg/min)

3. RR Trent 900 Engines for an OAT between -40 °C (-40 °F) and 55 °C (131 °F) at Sea Level

ASU OUTPUT TEMPERATURE RANGE	PRESSURE AT HPGC	MASS FLOW AT HPGC
100 °C (212 °F) - 130 °C (266 °F)	40 psig (55 psia)	270 ppm (123 kg/min)
130 °C (266 °F) - 165 °C (329 °F)	40 psig (55 psia)	260 ppm (118 kg/min)
165 °C (329 °F) - 210 °C (410 °F)	40 psig (55 psia)	248 ppm (113 kg/min)
210 °C (410 °F) - 255 °C (491 °F)	40 psig (55 psia)	238 ppm (108 kg/min)

5-6-0 Ground Pneumatic Power Requirements

****ON A/C A380-800**

Ground Pneumatic Power Requirements

1. General

This section describes the required performance for the ground equipment to maintain the cabin temperature at 27 °C (80.6 °F) for the cooling or 21 °C (69.8 °F) for the heating cases after boarding (Section 5.7 - steady state), and provides the time needed to cool down or heat up the aircraft cabin to the required temperature (Section 5.6 - dynamic cases with aircraft empty).

ABBREVIATION	DEFINITION
A/C	Aircraft
AHM	Aircraft Handling Manual
AMM	Aircraft Maintenance Manual
GC	Ground Connection
GSE	Ground Service Equipment
IFE	In-Flight Entertainment
LPGC	Low Pressure Ground Connection
OAT	Outside Air Temperature
PCA	Pre-Conditioned Air

- A. The air flow rates and temperature requirements for the GSE, provided in Sections 5.6 and 5.7, are given at A/C ground connection.

NOTE : The cooling capacity of the equipment (kW) is only indicative and is not sufficient by itself to ensure the performance (outlet temperature and flow rate combinations are the requirements needed for ground power).

An example of cooling capacity calculation is given in Section 5.7.

- B. The air flow rates and temperature requirements for the GSE are given for the A/C in the configuration "4 LP ducts connected".

NOTE : The maximum air flow is driven by pressure limitation at LPGC.

- C. For temperatures at ground connection below +2 °C (+35.6 °F) (Subfreezing), the ground equipment shall be compliant with the Airbus document "Subfreezing PCA Carts - Compliance Document for Suppliers" (contact Airbus to obtain this document) defining all the requirements with which Subfreezing Pre-Conditioning Air equipment must comply to allow its use on Airbus aircraft. These requirements are in addition to the functional specifications included in the IATA AHM997.

2. Ground Pneumatic Power Requirements

This section provides the ground pneumatic power requirements for:

- Heating (pull up) the cabin, initially at OAT, up to 21 °C (69.8 °F) (see FIGURE 5-6-0-991-001-A)
- Cooling (pull down) the cabin, initially at OAT, down to 27 °C (80.6 °F) (see FIGURE 5-6-0-991-002-A).

****ON A/C A380-800**

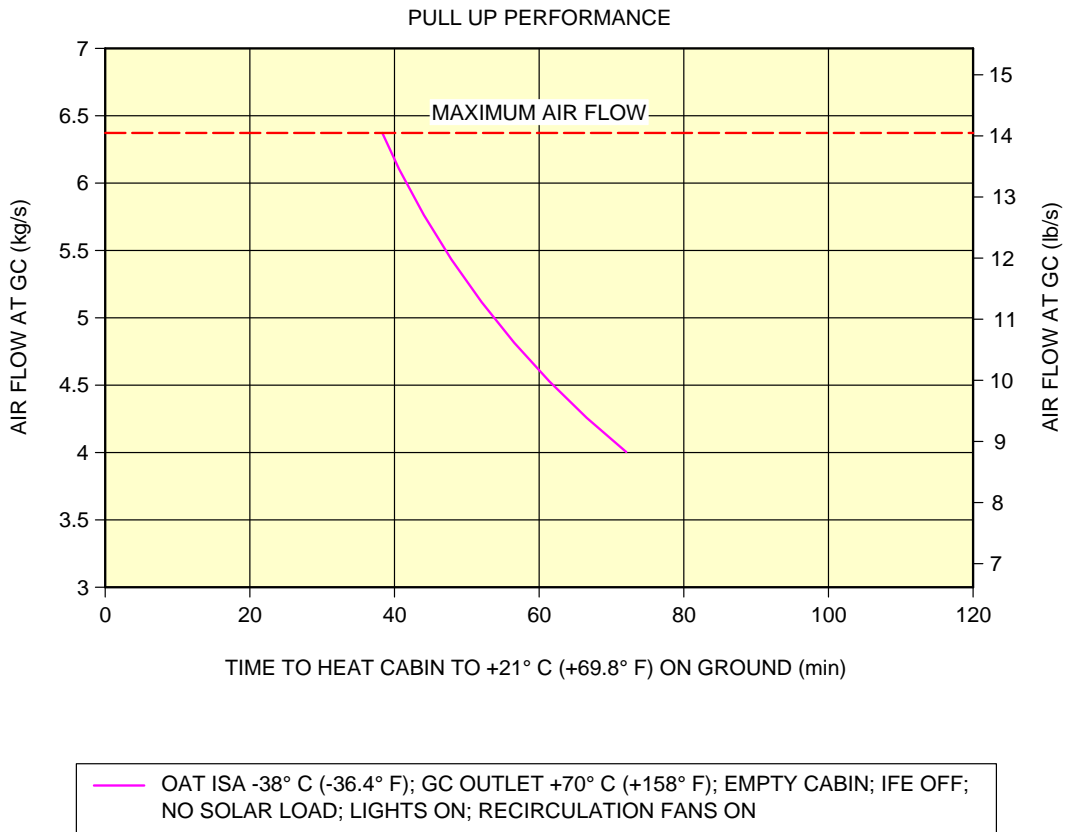

L_AC_050600_1_0010101_01_00

Ground Pneumatic Power Requirements
Heating
FIGURE-5-6-0-991-001-A01

****ON A/C A380-800**

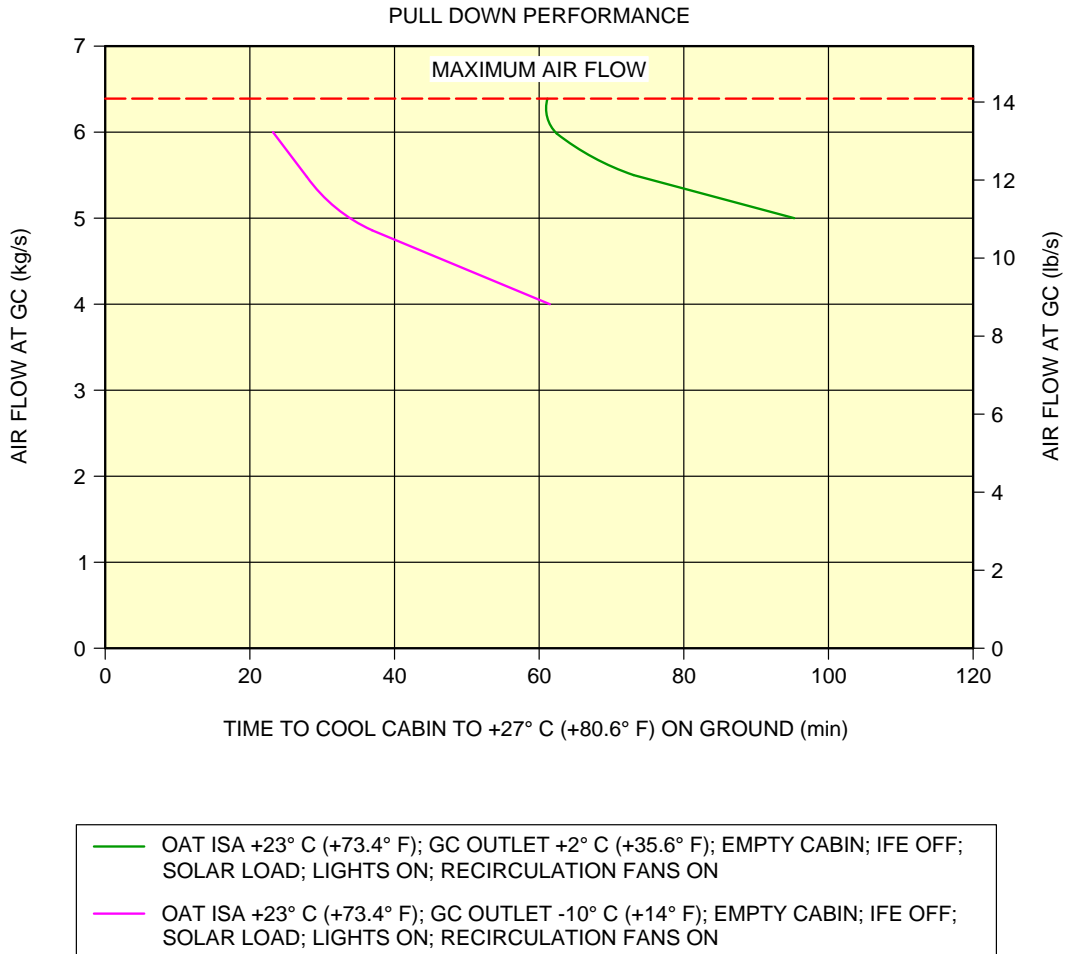

L_AC_050600_1_0020101_01_00

Ground Pneumatic Power Requirements
Cooling
FIGURE-5-6-0-991-002-A01

5-7-0 Preconditioned Airflow Requirements

****ON A/C A380-800**

Preconditioned Airflow Requirements

1. This section provides the preconditioned airflow rate and temperature needed to maintain the cabin temperature at 27 °C (80.6 °F) for the cooling or 21 °C (69.8 °F) for the heating cases.

These settings are not intended to be used for operation (they are not a substitute for the settings given in the AMM). They are based on theoretical simulations and give the picture of a real steady state.

For the air conditioning (cooling) operation, the AMM details the procedure and the preconditioned airflow settings to maintain the cabin temperature below 27 °C (80.6 °F) during boarding (therefore it is not a steady state).

****ON A/C A380-800**

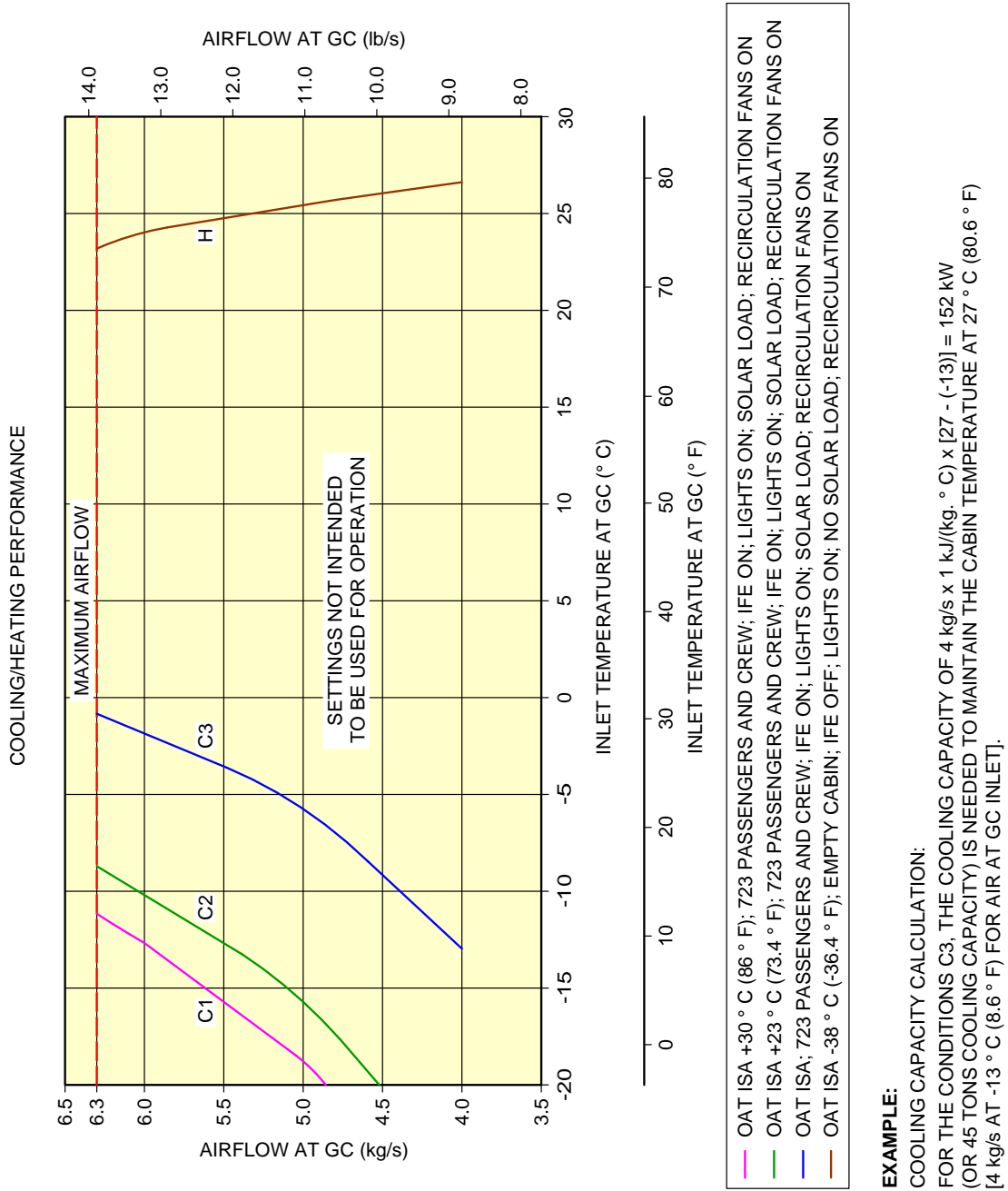

L_AC_050700_1_0010101_01_05

Preconditioned Airflow Requirements
 FIGURE-5-7-0-991-001-A01

5-8-0 Ground Towing Requirements

**ON A/C A380-800

Ground Towing Requirements

1. This section provides information on aircraft towing.

The A380-800 is designed with means for conventional or towbarless towing. Information/procedures can be found for both in AMM 09.

Status on towbarless towing equipment qualification can be found in ISI 09.11.00001.

It is possible to tow or push the aircraft, at maximum ramp weight with engines at zero or up to idle thrust, using a towbar attached to the NLG. The towbar fitting is installed at the front of the leg (optional towing fitting for towing from the rear of the NLG available).

The body gears have attachment points for towing or debogging (for details, refer ARM 07).

This section shows the chart to determine the drawbar pull and tow tractor mass requirements as a function of the following physical characteristics, see FIGURE 5-8-0-991-001-A:

- Aircraft weight,
- Number of engines at idle,
- Slope.

The chart is based on the A380-800 engine type with the highest idle thrust. The chart is therefore valid for all A380-800 models.

2. Towbar design guidelines

The aircraft towbar shall comply with the following standards:

- SAE AS 1614, "Main Line Aircraft Towbar Attach Fitting Interface",
- SAE ARP1915, "Aircraft Towbar",
- ISO 8267-1, "Aircraft - Towbar Attachment Fitting - Interface Requirements - Part 1: Main Line Aircraft",
- ISO 9667, "Aircraft Ground Support Equipment - Towbars",
- IATA Airport Handling Manual AHM 958, "Functional Specification for an Aircraft Towbar".

A conventional type towbar should be equipped with a damping system (to protect the NLG against jerks), a rotating toweye and with towing shear pins:

- A traction shear pin calibrated at 62 000 daN (139 382 lbf),
- A torsion pin calibrated at 4 800 m.daN (424 779 lbf.in).

The towing head is designed according to ISO 8267-1, cat. V.

****ON A/C A380-800**

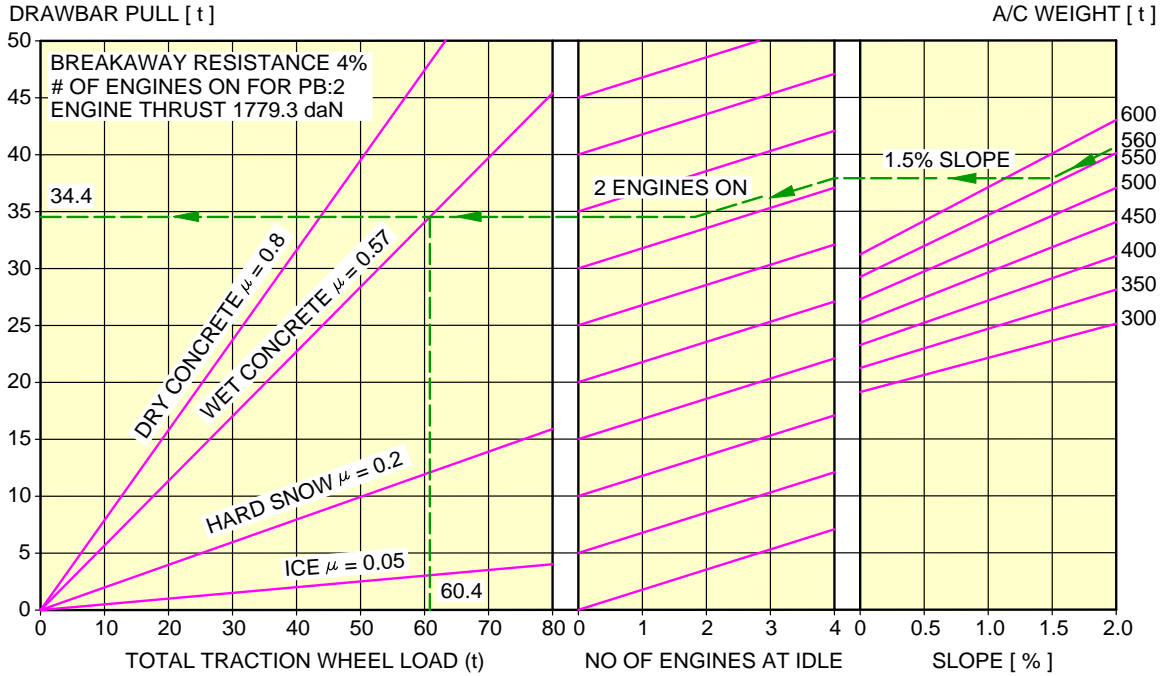

EXAMPLE HOW TO DETERMINE THE TRACTION WHEEL LOAD REQUIREMENT TO TOW A A380 AT 560 t, AT 1.5% SLOPE, 2 ENGINES AT IDLE AND FOR WET TARMAC CONDITIONS:

- ON THE RIGHT HAND SIDE OF THE GRAPH, CHOOSE THE RELEVANT AIRCRAFT WEIGHT (560 t),
- FROM THIS POINT DRAW A PARALLEL LINE TO THE REQUIRED SLOPE PERCENTAGE (1.5%),
- FROM THE POINT OBTAINED DRAW A STRAIGHT HORIZONTAL LINE UNTIL No. OF ENGINES AT IDLE = 4,
- FROM THIS POINT DRAW A PARALLEL LINE TO THE REQUESTED NUMBER OF ENGINES (2),
- FROM THIS POINT DRAW A STRAIGHT HORIZONTAL LINE TO THE DRAWBAR PULL AXIS,
- THE Y-COORDINATE OBTAINED IS THE NECESSARY DRAWBAR PULL FOR THE TRACTOR (34.4 t),
- SEARCH THE INTERSECTION WITH THE "WET CONCRETE" LINE.
- THE OBTAINED X-COORDINATE IS THE RECOMMENDED MINIMUM TRACTION WHEEL LOAD (60.4 t).

NOTE:

FOR ALL WHEEL-DRIVEN VEHICLES, THE TOTAL TRACTION WHEEL LOAD IS THE TRACTOR WEIGHT.

L_AC_050800_1_0010101_01_04

Ground Towing Requirements
FIGURE-5-8-0-991-001-A01

****ON A/C A380-800**

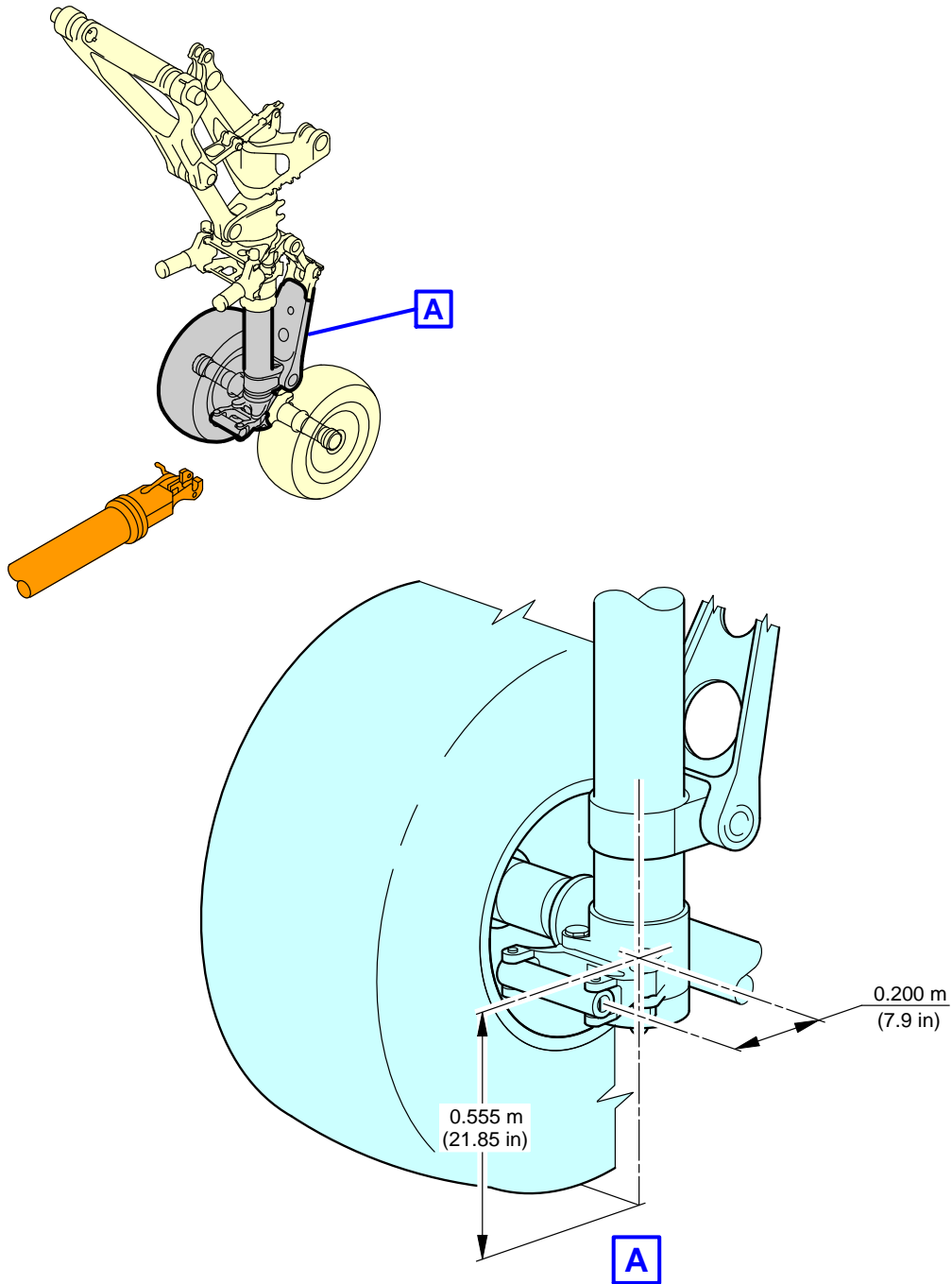

L_AC_050800_1_0040101_01_00

Ground Towing Requirements
Nose Gear Towing Fittings
FIGURE-5-8-0-991-004-A01

5-9-0 De-icing and External Cleaning

****ON A/C A380-800**

De-icing and External Cleaning

1. De-icing and External Cleaning on Ground

The mobile equipment for aircraft de-icing and external cleaning must be capable of reaching heights up to approximately 24 m (79 ft).

2. De-icing

AIRCRAFT TYPE	Wing Top Surface (Both Sides)	Wingtip Devices (Both Inside and Outside Surfaces) (Both Sides)	HTP Top Surface (Both Sides)	VTP (Both Sides)
A380 - 800	723 m ² (7 782 ft ²)	10 m ² (108 ft ²)	186 m ² (2 002 ft ²)	230 m ² (2 476 ft ²)

AIRCRAFT TYPE	Fuselage Top Surface (Top Third - 120° Arc)	Nacelle and Pylon (Top Third - 120° Arc) (All Engines)	Total De-Iced Area
A380 - 800	497 m ² (5 350 ft ²)	112 m ² (1 206 ft ²)	1 757 m ² (18 912 ft ²)

NOTE : Dimensions are approximate.

3. External Cleaning

AIRCRAFT TYPE	Wing Top Surface (Both Sides)	Wing Lower Surface (Including Flap Track Fairing) (Both Sides)	Wingtip Devices (Both Inside and Outside Surfaces) (Both Sides)	HTP Top Surface (Both Sides)	HTP Lower Surface (Both Sides)
A380 - 800	723 m ² (7 782 ft ²)	794 m ² (8 547 ft ²)	10 m ² (108 ft ²)	186 m ² (2 002 ft ²)	186 m ² (2 002 ft ²)



AIRCRAFT CHARACTERISTICS - AIRPORT AND MAINTENANCE PLANNING

AIRCRAFT TYPE	VTP (Both Sides)	Fuselage and Belly Fairing	Nacelle and Pylon (All Engines)	Total Cleaned Area
A380 - 800	230 m ² (2 476 ft ²)	1 531 m ² (16 480 ft ²)	373 m ² (4 015 ft ²)	4 034 m ² (43 422 ft ²)

NOTE : Dimensions are approximate.

OPERATING CONDITIONS**6-1-0 Engine Exhaust Velocities and Temperatures******ON A/C A380-800**Engine Exhaust Velocities and Temperatures

1. General

This section provides the estimated engine exhaust efflux velocity and temperature contours for Maximum Take-off, Breakaway and Idle conditions for the A380 engine.

Contours are available for both Rolls-Royce's Trent 900 engine and the Engine Alliance's GP7200 engine.

The Maximum Take-off data are presented at the maximum thrust rating for all the A380 engine.

The Breakaway data are presented at a rating corresponding to the minimum thrust level required to initiate movement of an A380-800 at its maximum ramp weight from static position and on uphill ground.

The Idle data are directly provided by the engine manufacturers.

In the charts, longitudinal distances are measured from the inboard engine core nozzle exit station, while lateral distances are measured from the aircraft fuselage centerline.

A. Data from Rolls-Royce's Trent 900:

The estimated efflux data are presented at ISA +15°C (+59°F), Sea Level Static and negligible wind conditions.

The analysis assumes that the core and bypass streams are fully mixed and calculates the jet behaviour in free, still air and therefore does not take into account effects such as on-wing installation, ground entrainment and ambient wind conditions.

Velocity contours are presented at 50 ft/s (15 m/s), 100 ft/s (30 m/s) and 150 ft/s (46 m/s), while temperature contours are presented at 104 °F (40°C), 122°F (50°C) and 140°F (60 °C).

B. Data from Engine Alliance's GP7200:

The estimated efflux data are presented at ISA +15°C (+59°F), Sea Level Static with 20 kt headwind. It also assumed ground plane and proximity effects. Velocity contours are presented at 35 mph (16 m/s), 65 mph (29 m/s) and 105 mph (47 m/s), while temperature contours are presented at 122°F (50°C), 212°F (100°C) and 392°F (200°C). Engine Alliance strongly recommends that jet blast studies using their contours include the effect of a 20 kt headwind.

6-1-1 Engine Exhaust Velocities - Ground Idle Power****ON A/C A380-800**Engine Exhaust Velocities - Ground Idle Power

1. This section gives engine exhaust velocities at ground idle power.

****ON A/C A380-800**

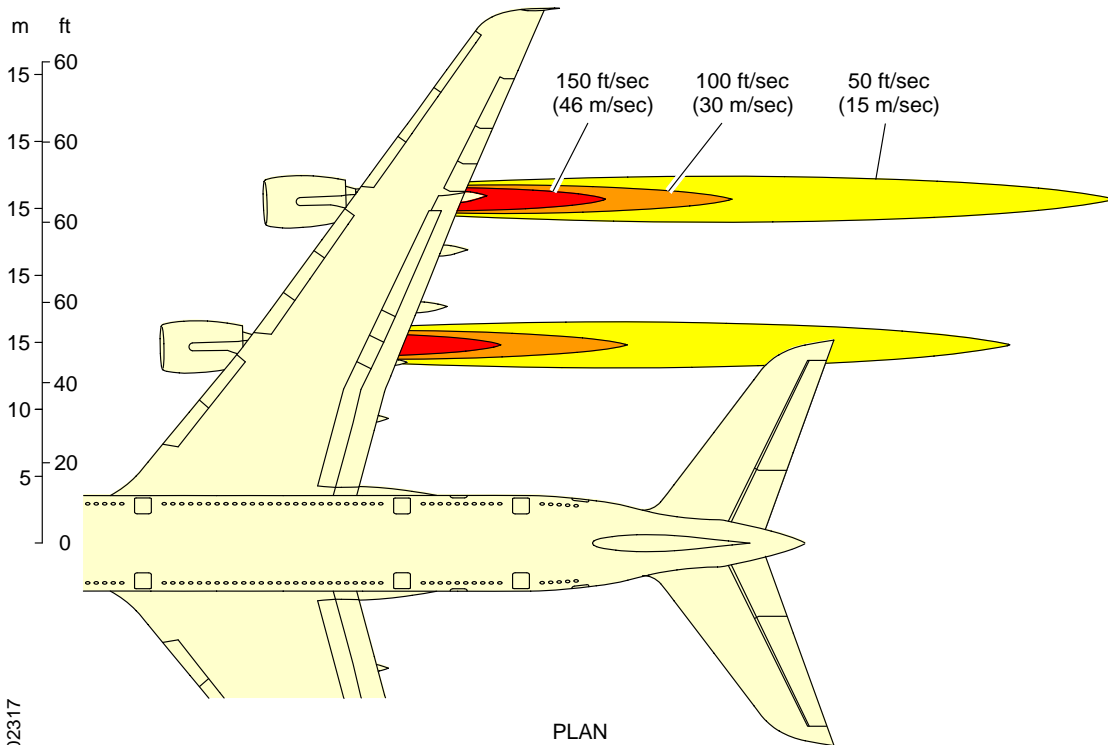
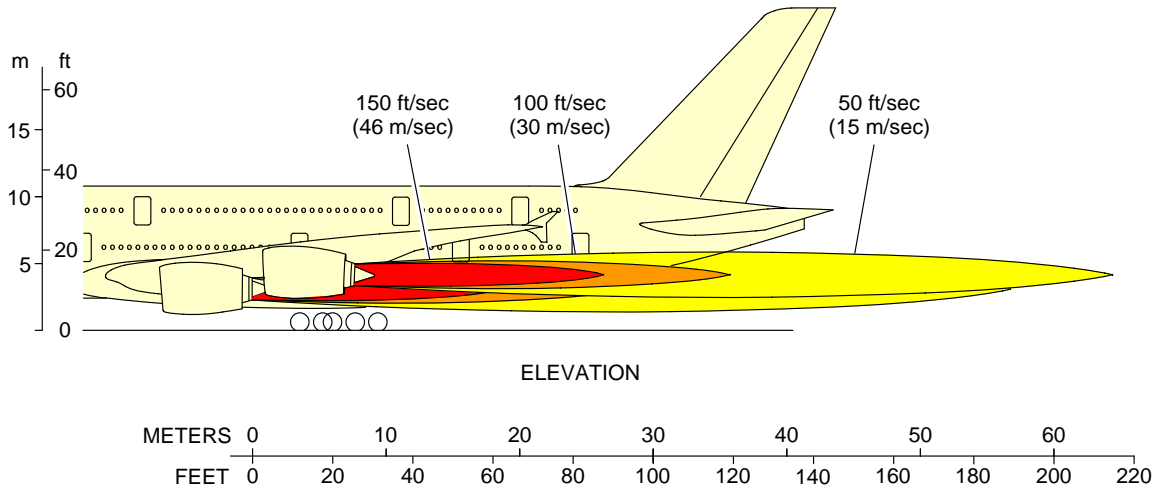

deh0002317

L_AC_060101_1_0010101_01_00

Engine Exhaust Velocities
Ground Idle Power - TRENT 900 Engines
FIGURE-6-1-1-991-001-A01

**ON A/C A380-800

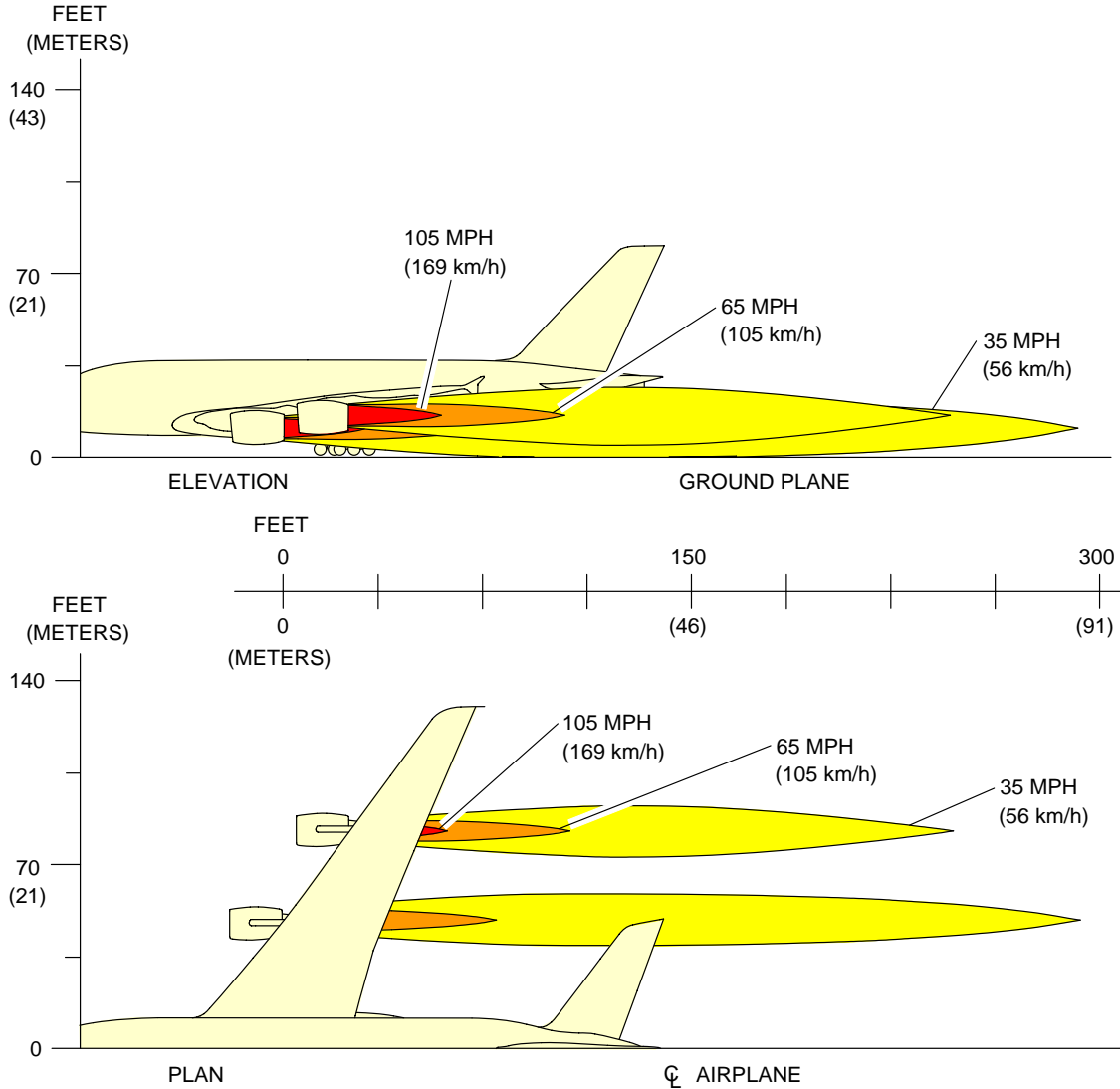

NOTE: ALL VELOCITY VALUES ARE IN STATUE MILES PER HOUR.
 CONVERSION FACTOR
 1 MPH = 1.6 km/h
 DANGER (KEEP OUT) ZONES \geq 35 MPH

E-00224 (0207)
 PW V

L_AC_060101_1_0020101_01_01

Engine Exhaust Velocities
 Ground Idle Power - GP 7200 Engines
 FIGURE-6-1-1-991-002-A01

6-1-2 Engine Exhaust Temperatures - Ground Idle Power****ON A/C A380-800**Engine Exhaust Temperatures - Ground Idle Power

1. This section gives engine exhaust temperatures at ground idle power.

****ON A/C A380-800**

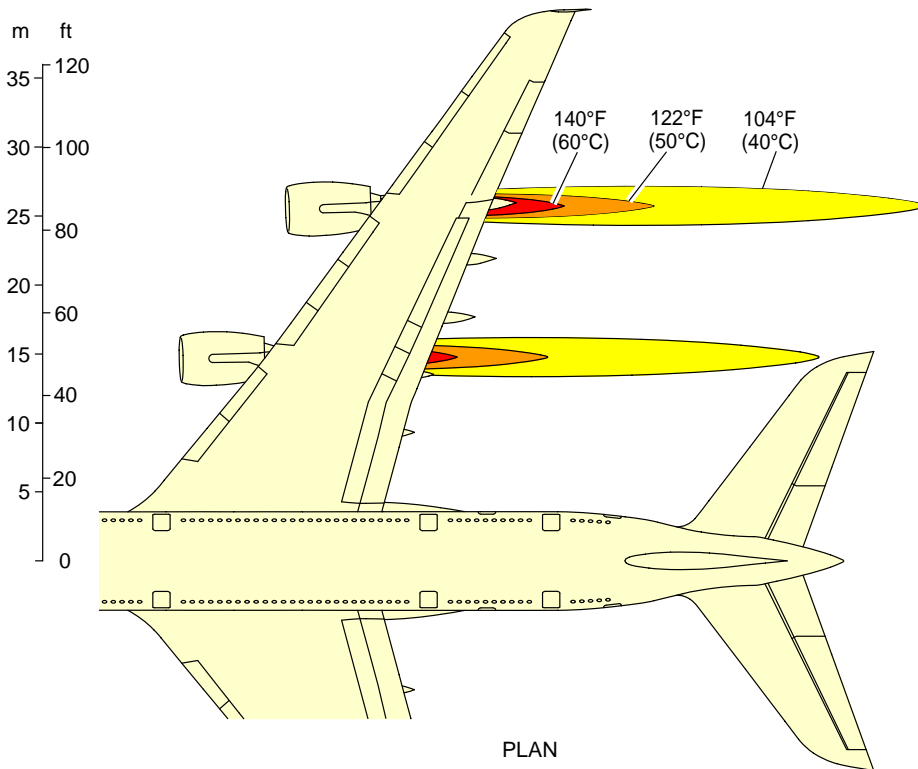
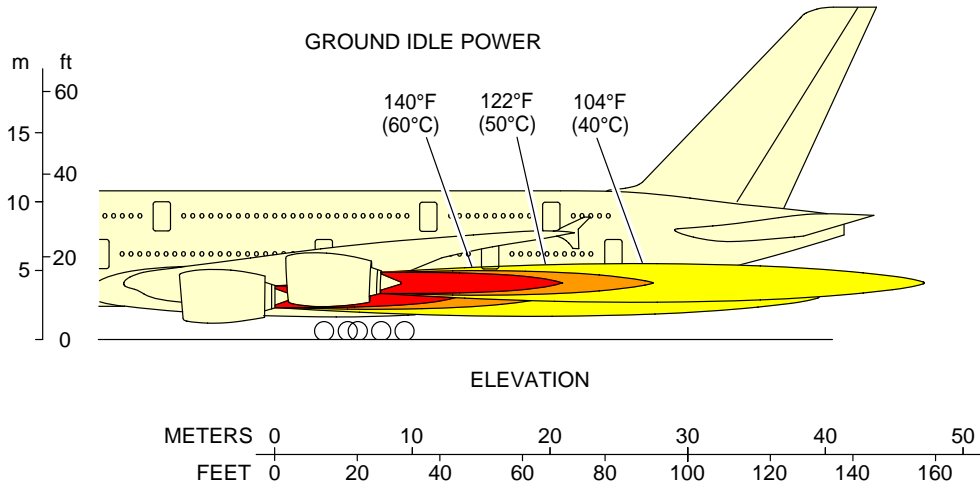

deh0002316

L_AC_060102_1_0010101_01_01

Engine Exhaust Temperatures
Ground Idle Power - TRENT 900 Engines
FIGURE-6-1-2-991-001-A01

****ON A/C A380-800**

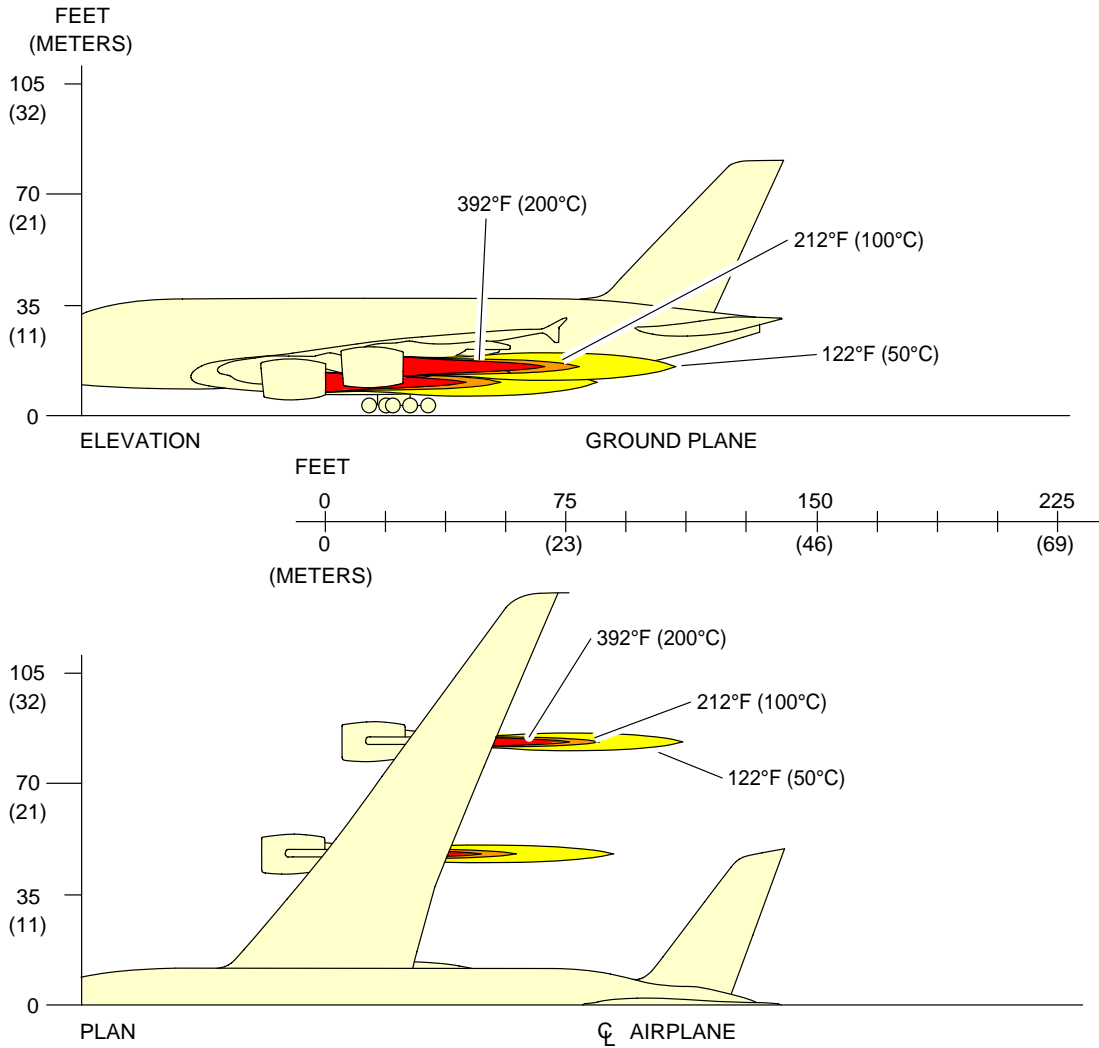

NOTE: ALL TEMPERATURES ARE IN FAHRENHEIT (CELSIUS).

E-002226 (0207)
PW V

L_AC_060102_1_0020101_01_01

Engine Exhaust Temperatures
 Ground Idle Power - GP 7200 Engines
 FIGURE-6-1-2-991-002-A01

6-1-3 Engine Exhaust Velocities - Breakaway Power****ON A/C A380-800**Engine Exhaust Velocities - Breakaway Power

1. This section gives engine exhaust velocities at breakaway power.

****ON A/C A380-800**

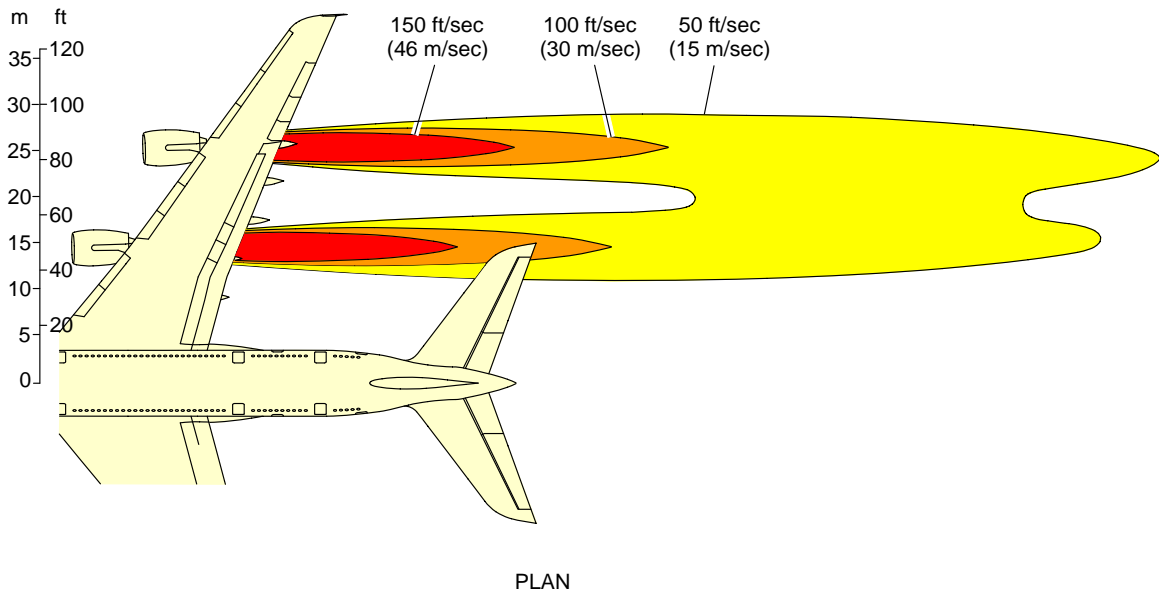
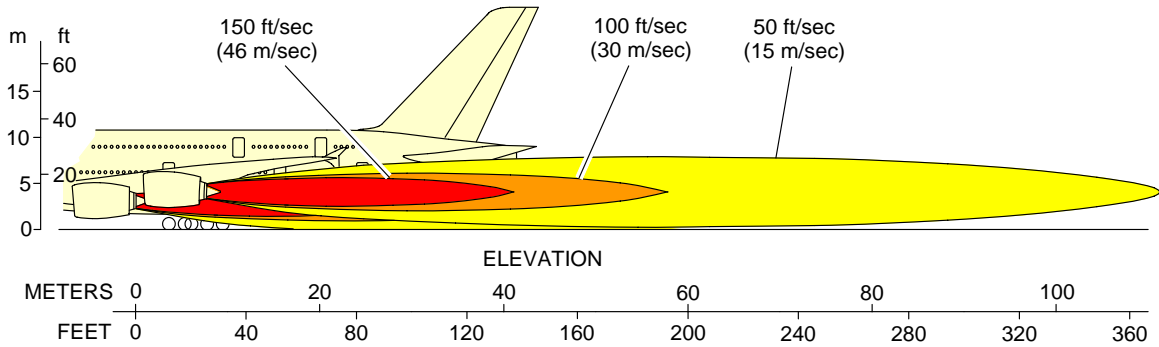

deh0002319

L_AC_060103_1_0010101_01_00

Engine Exhaust Velocities
Breakaway Power - TRENT 900 Engines
FIGURE-6-1-3-991-001-A01

****ON A/C A380-800**

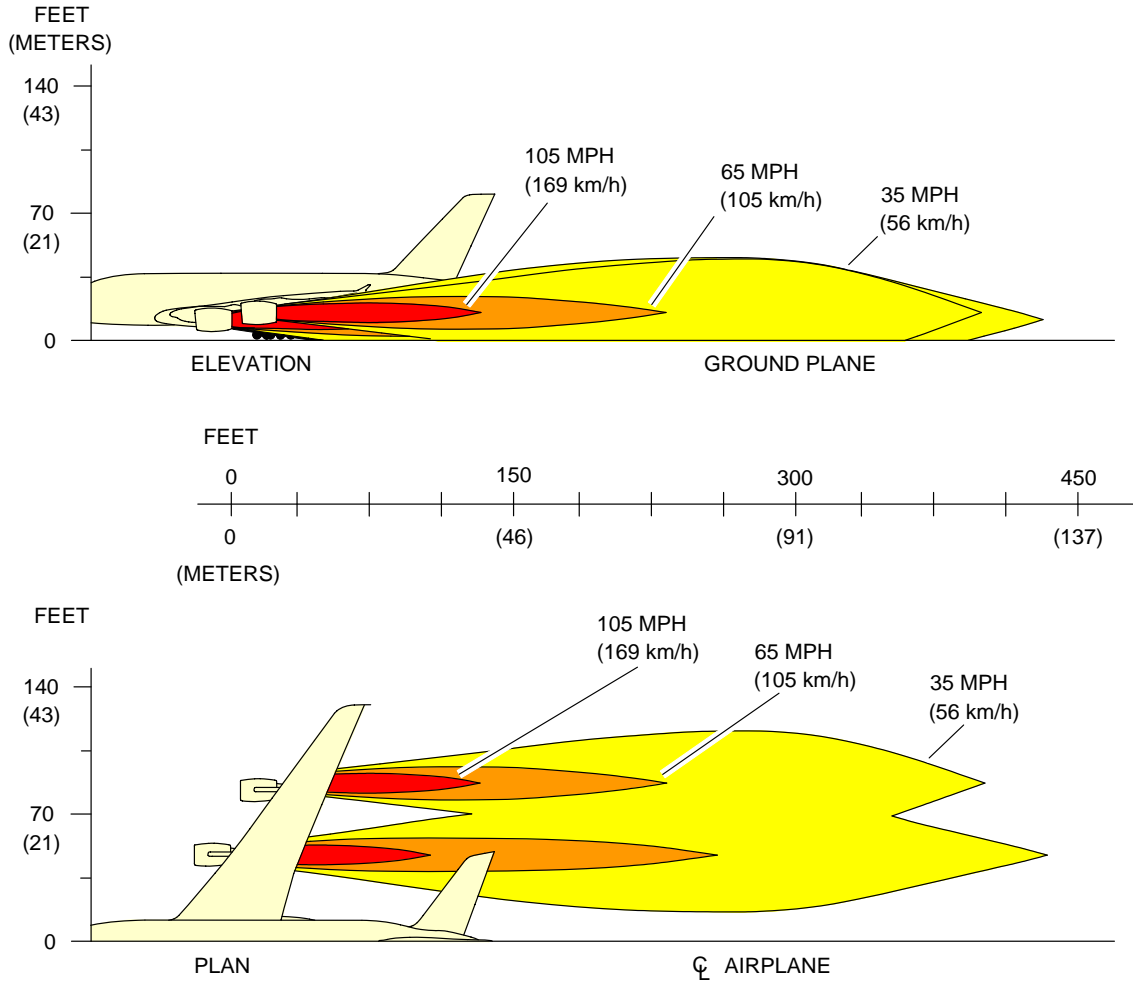

E-02200 (0207)
PW V

NOTE: ALL VELOCITY VALUES ARE IN STATUE MILES PER HOUR.
CONVERSION FACTOR
1 MPH = 1.6 km/h
DANGER (KEEP OUT) ZONES \geq 35 MPH

L_AC_060103_1_0020101_01_01

Engine Exhaust Velocities
Breakaway Power - GP 7200 Engines
FIGURE-6-1-3-991-002-A01

6-1-4 Engine Exhaust Temperatures - Breakaway Power****ON A/C A380-800**Engine Exhaust Temperatures - Breakaway Power

1. This section gives engine exhaust temperatures at breakaway power.

****ON A/C A380-800**

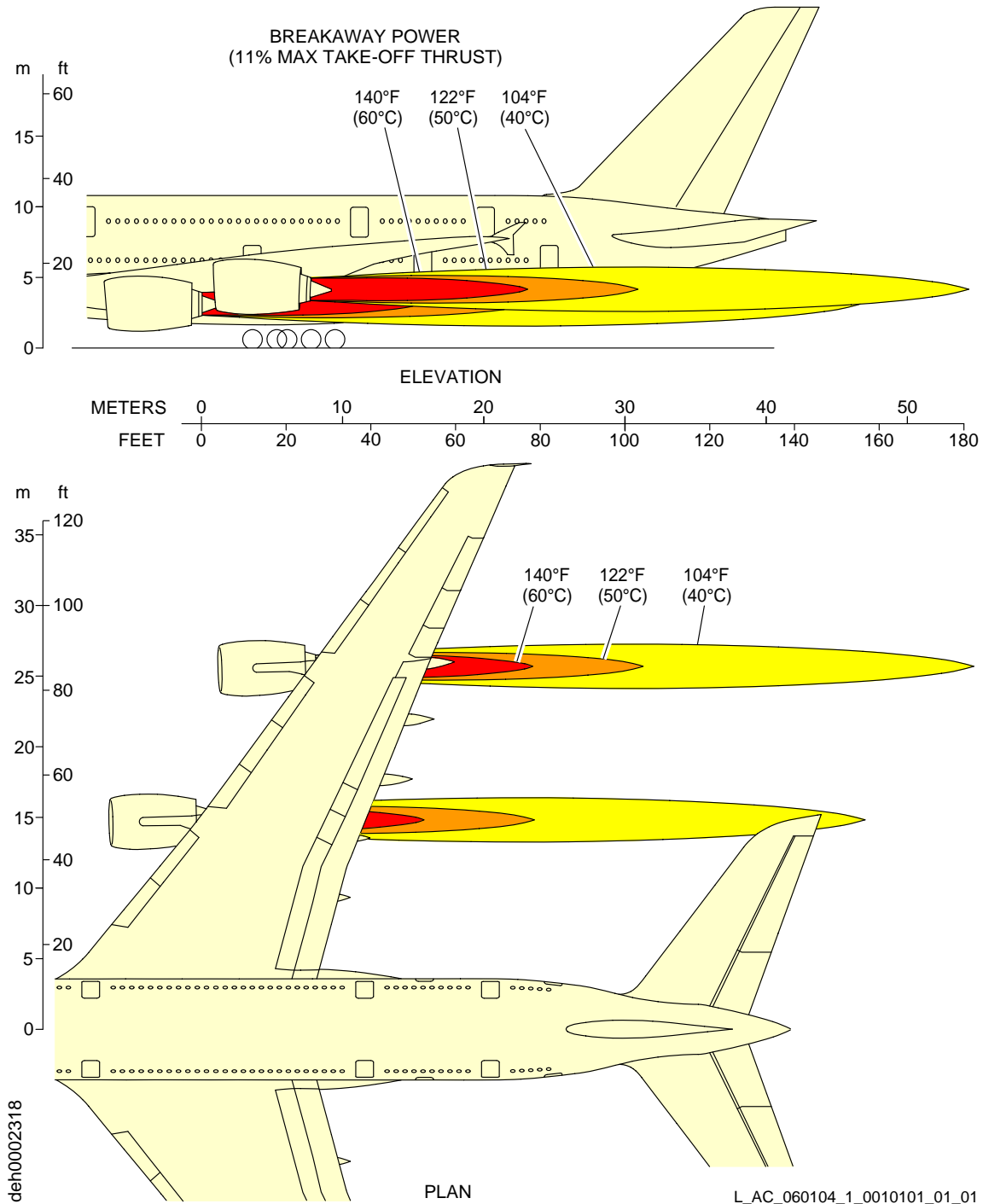

Engine Exhaust Temperatures
Breakaway Power - TRENT 900 Engines
FIGURE-6-1-4-991-001-A01

****ON A/C A380-800**

E-02201 (0805)
PW V

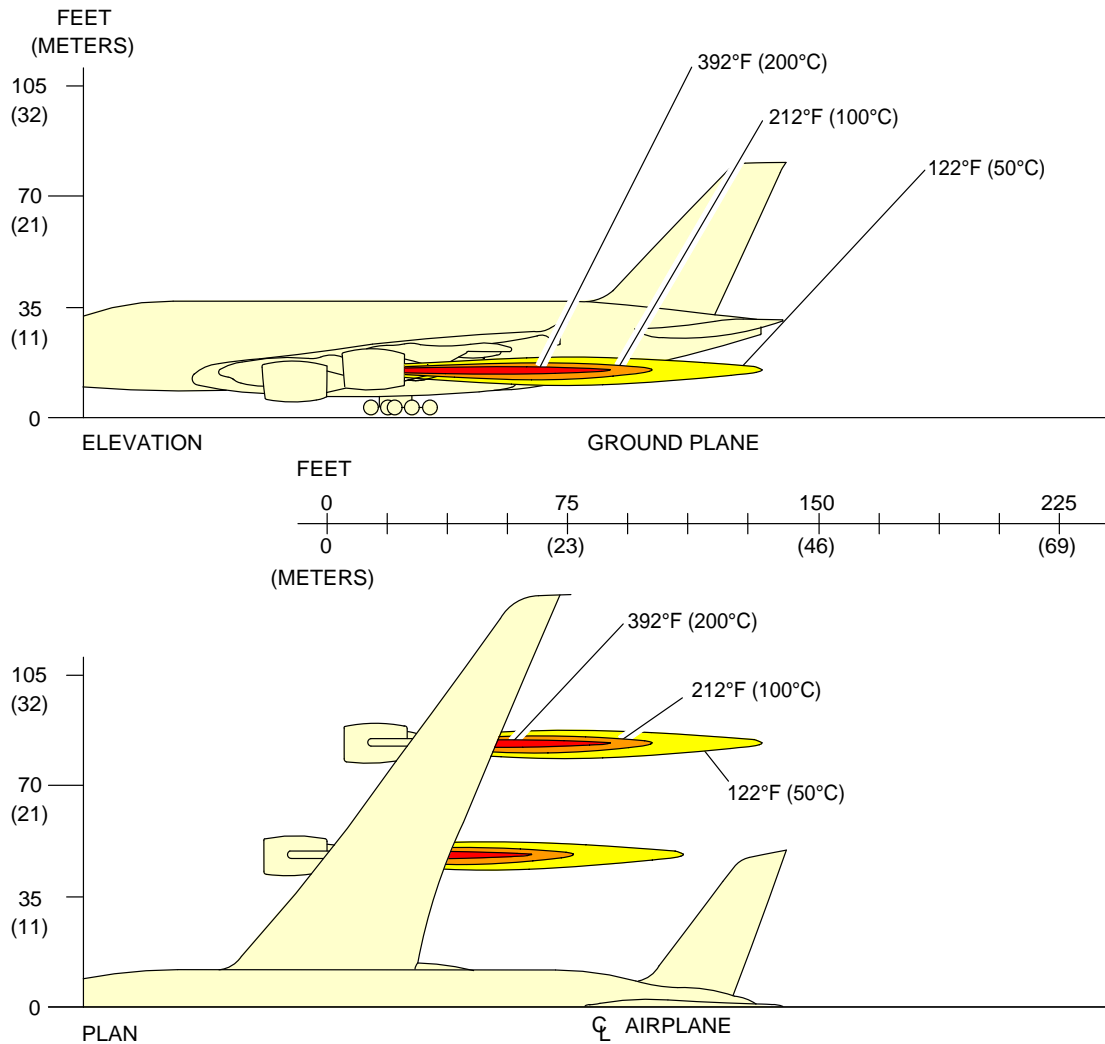

NOTE : ALL TEMPERATURES ARE IN FAHRENHEIT (CELSIUS).

L_AC_060104_1_0020101_01_00

Engine Exhaust Temperatures
Breakaway Power - GP 7200 Engines
FIGURE-6-1-4-991-002-A01

6-1-5 Engine Exhaust Velocities - Max Take-off Power****ON A/C A380-800**Engine Exhaust Velocities - Max Take-off Power

1. This section gives engine exhaust velocities at max take-off power.

****ON A/C A380-800**

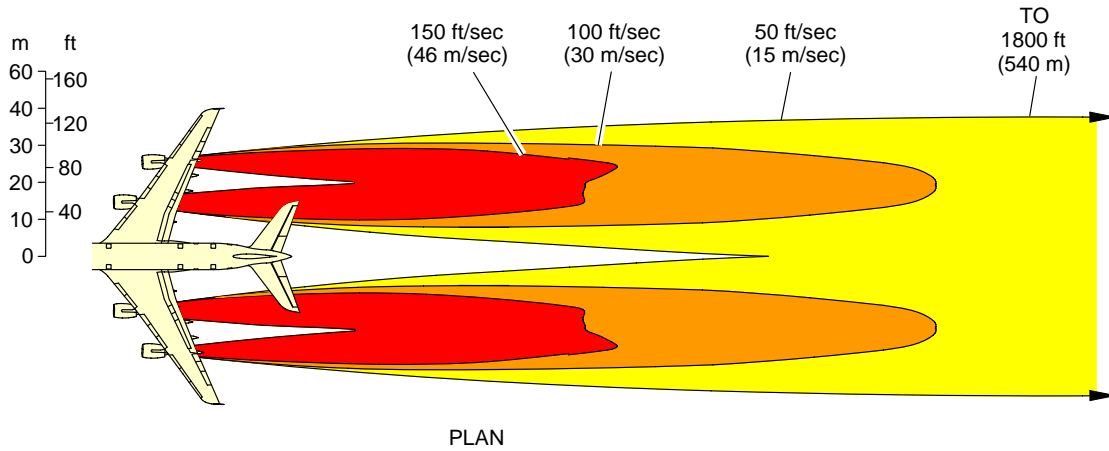
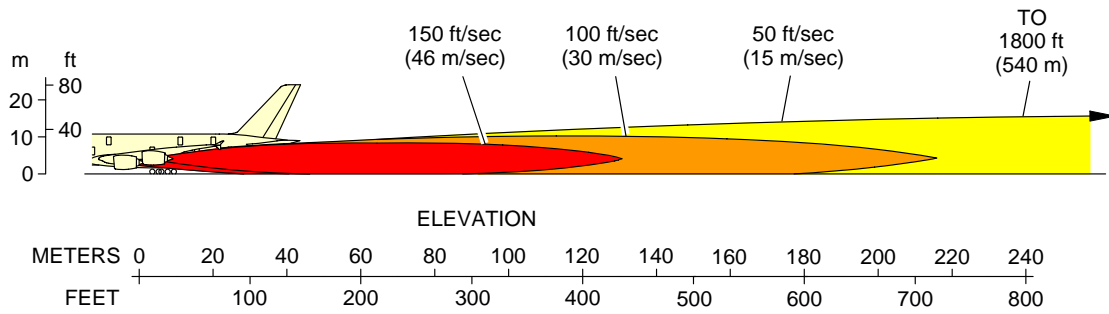

deh0002315

L_AC_060105_1_0010101_01_00

Engine Exhaust Velocities
Max. Take-Off Power - TRENT 900 Engines
FIGURE-6-1-5-991-001-A01

****ON A/C A380-800**

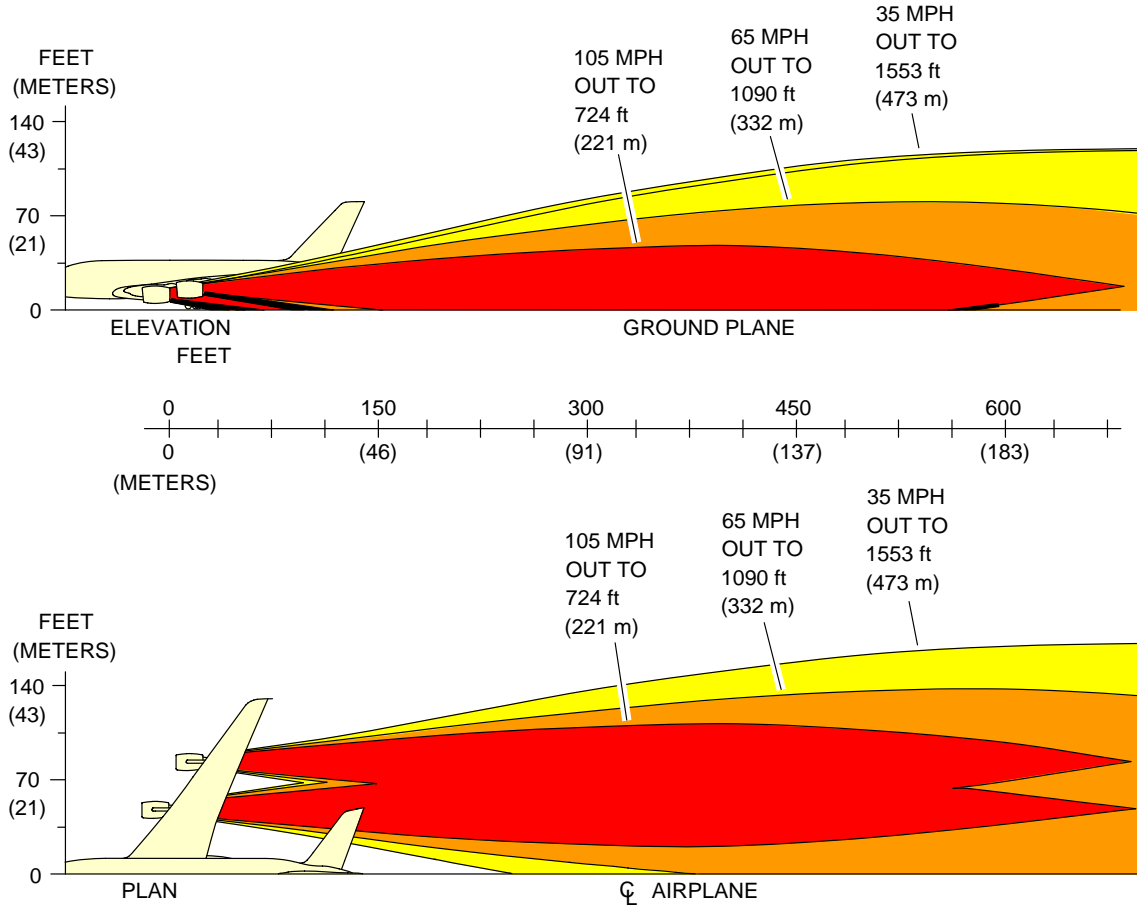

E-00225 (0207)
PW V

NOTE: ALL VELOCITY VALUES ARE IN STATUE MILES PER HOUR.
CONVERSION FACTOR
1 MPH = 1.6 km/h
DANGER (KEEP OUT) ZONES \geq 35 MPH

L_AC_060105_1_0020101_01_01

Engine Exhaust Velocities
Max. Take-Off Power - GP 7200 Engines
FIGURE-6-1-5-991-002-A01

6-1-6 Engine Exhaust Temperatures - Max Take-off Power****ON A/C A380-800**Engine Exhaust Temperatures - Max Take-off Power

1. This section gives engine exhaust temperatures at max take-off power.

****ON A/C A380-800**

MAX TAKE-OFF POWER

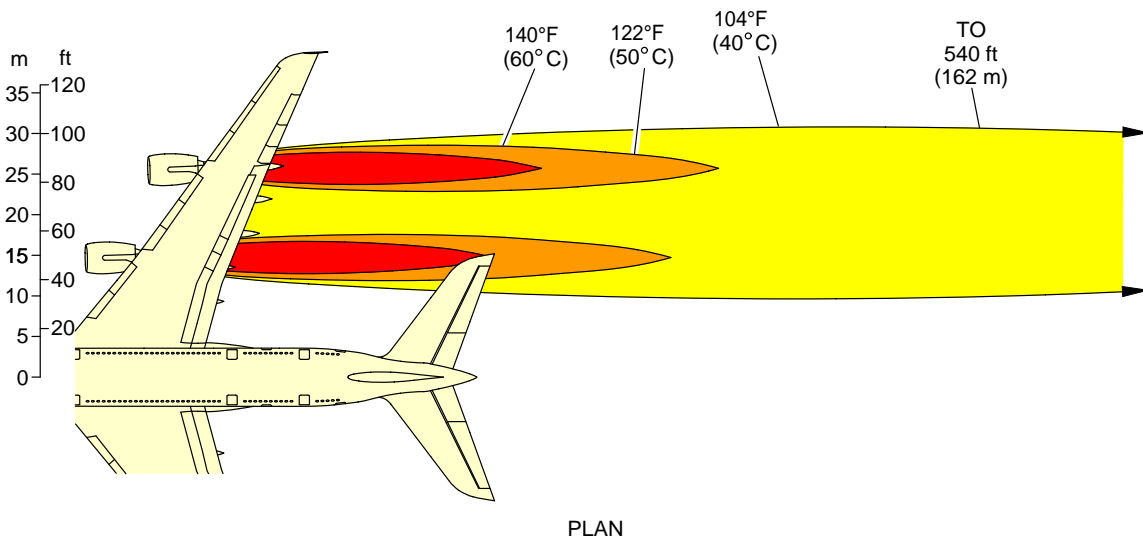
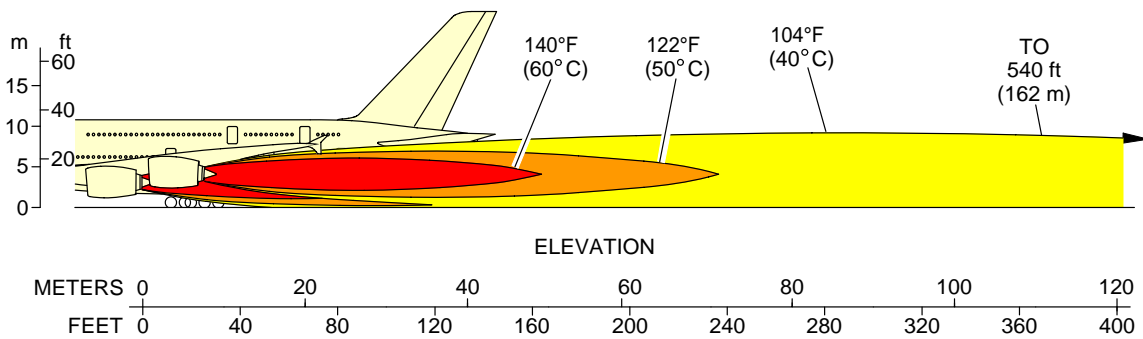

deh0002314

L_AC_060106_1_0010101_01_01

Engine Exhaust Temperatures
Max Take-Off Power - TRENT 900 Engines
FIGURE-6-1-6-991-001-A01

****ON A/C A380-800**

E-00227 (0704)
PW V

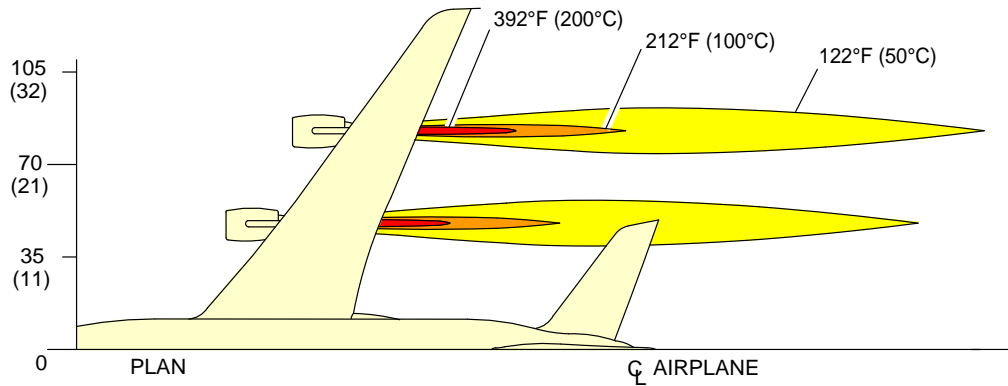
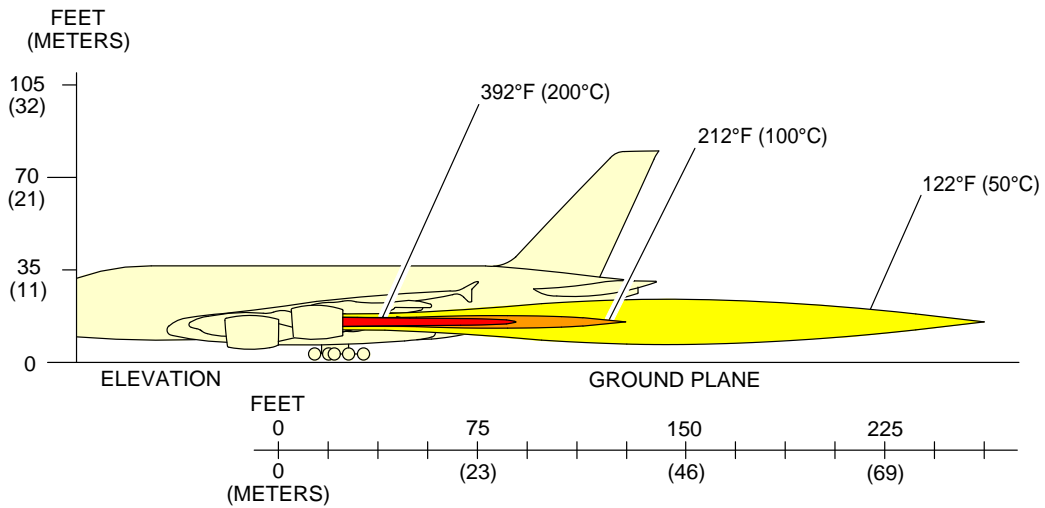

NOTE : ALL TEMPERATURES ARE IN FAHRENHEIT (CELSIUS).

L_AC_060106_1_0020101_01_00

Engine Exhaust Temperatures
Max Take-Off Power - GP 7200 Engines
FIGURE-6-1-6-991-002-A01

6-3-0 Danger Areas of the Engines

****ON A/C A380-800**

Danger Areas of the Engines

1. Danger Areas of the Engines

The intake suction danger areas, which are plotted in this chapter, correspond to very low suction velocities in order to prevent very low density objects (hat, handkerchief) from ingestion by engines. The primary aim of those danger areas is to protect the people working around the engines.

The A380 outer engines are high enough above ground to prevent the ingestion of typical loose objects, which can be found on ground at the edge of runways/taxiways paved areas (loose gravels for example), in the following conditions:

- at usual taxiway thrust (i.e. up to the breakaway power setting), even if the loose objects are below the A380 outer engines.
- at usual take-off thrust (i.e. up to the maximum take-off power setting), if the loose objects are beyond 3 meters from the A380 outer engines centreline.

6-3-1 Danger Areas of the Engines - Ground Idle Power****ON A/C A380-800**Danger Areas of the Engines - Ground Idle Power



1. This section gives danger areas of the engines at ground idle power conditions.

NOTE : The access to the inner engine is possible only if the outer engine is off.

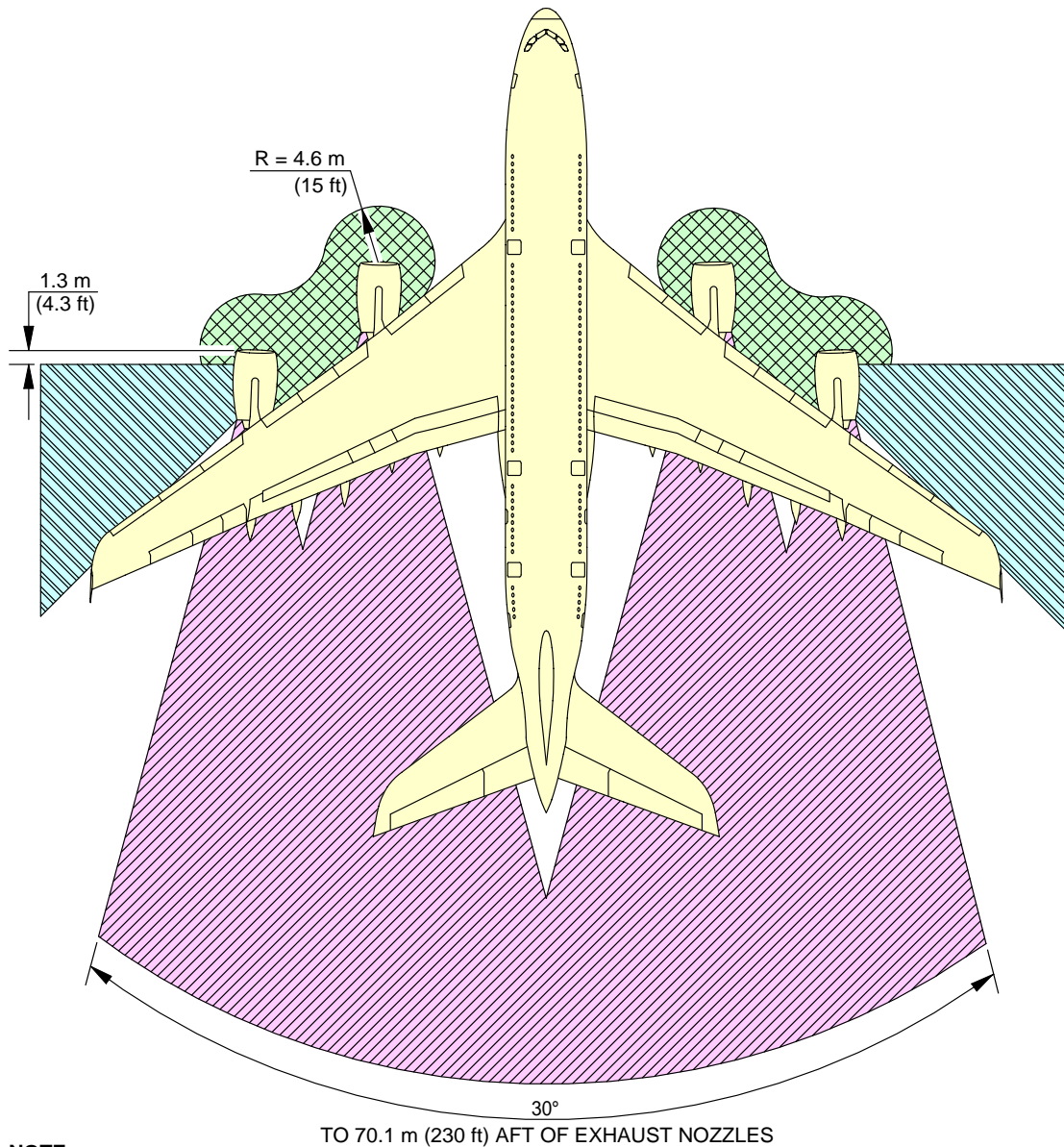
****ON A/C A380-800**



NOTE:

-  INTAKE SUCTION DANGER AREA MINIMUM IDLE POWER
-  EXHAUST DANGER AREA
-  ENTRY CORRIDOR

L_AC_060301_1_0010101_01_01

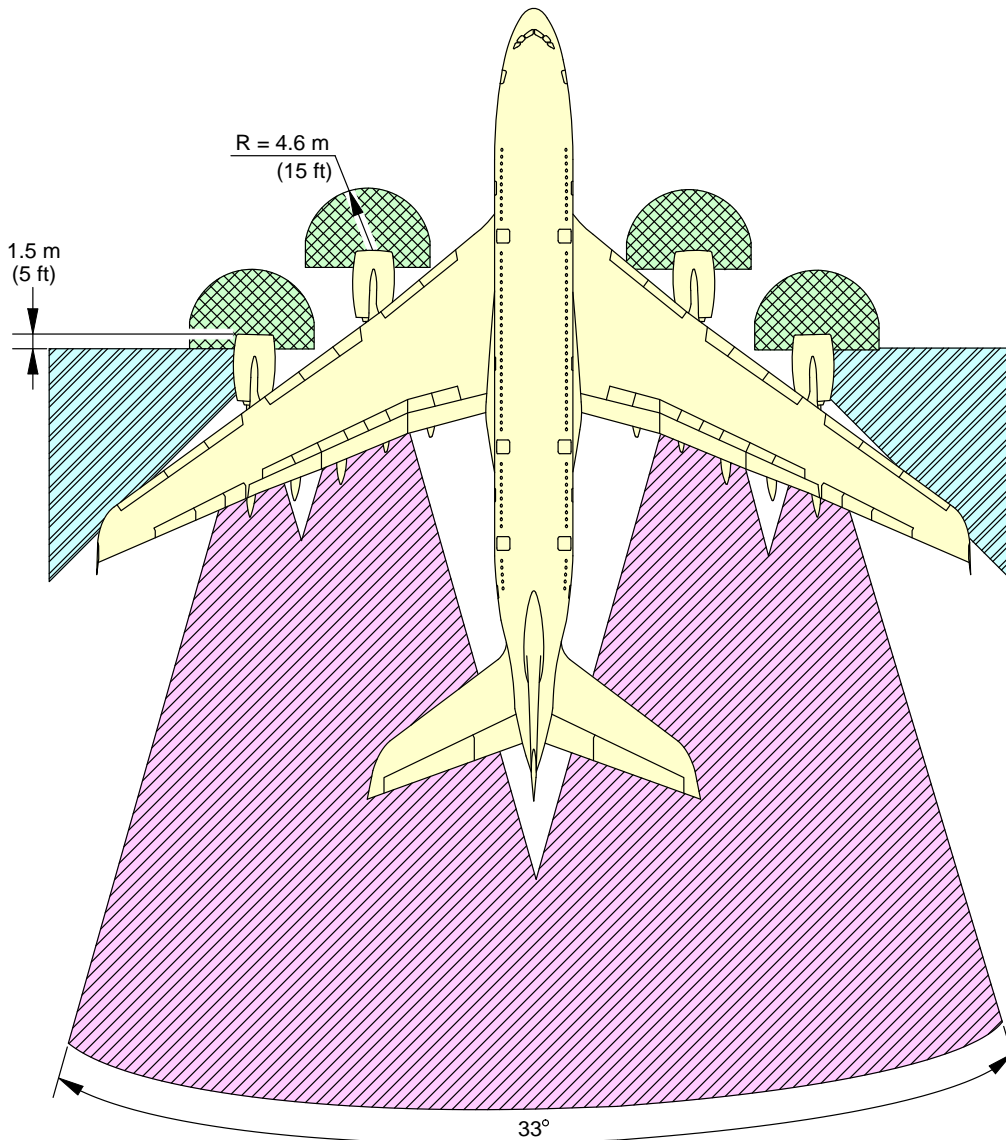

Danger Areas of the Engines
Ground Idle Power - TRENT 900 Engines
FIGURE-6-3-1-991-001-A01

****ON A/C A380-800**



UP TO 84.4 m (277 ft) AFT OF EXHAUST NOZZLES
(20 kt HEADWIND)

NOTE:

-  INTAKE SUCTION DANGER AREA
-  ENTRY CORRIDOR
-  EXHAUST DANGER AREA

L_AC_060301_1_0020101_01_02

Danger Areas of the Engines
Ground Idle Power - GP 7200 Engines
FIGURE-6-3-1-991-002-A01

6-3-2 Danger Areas of the Engines - Max. Take-Off Power****ON A/C A380-800**Danger Areas of the Engines - Max. Take-Off Power

1. This section gives danger areas of the engines at max take-off power conditions.

****ON A/C A380-800**

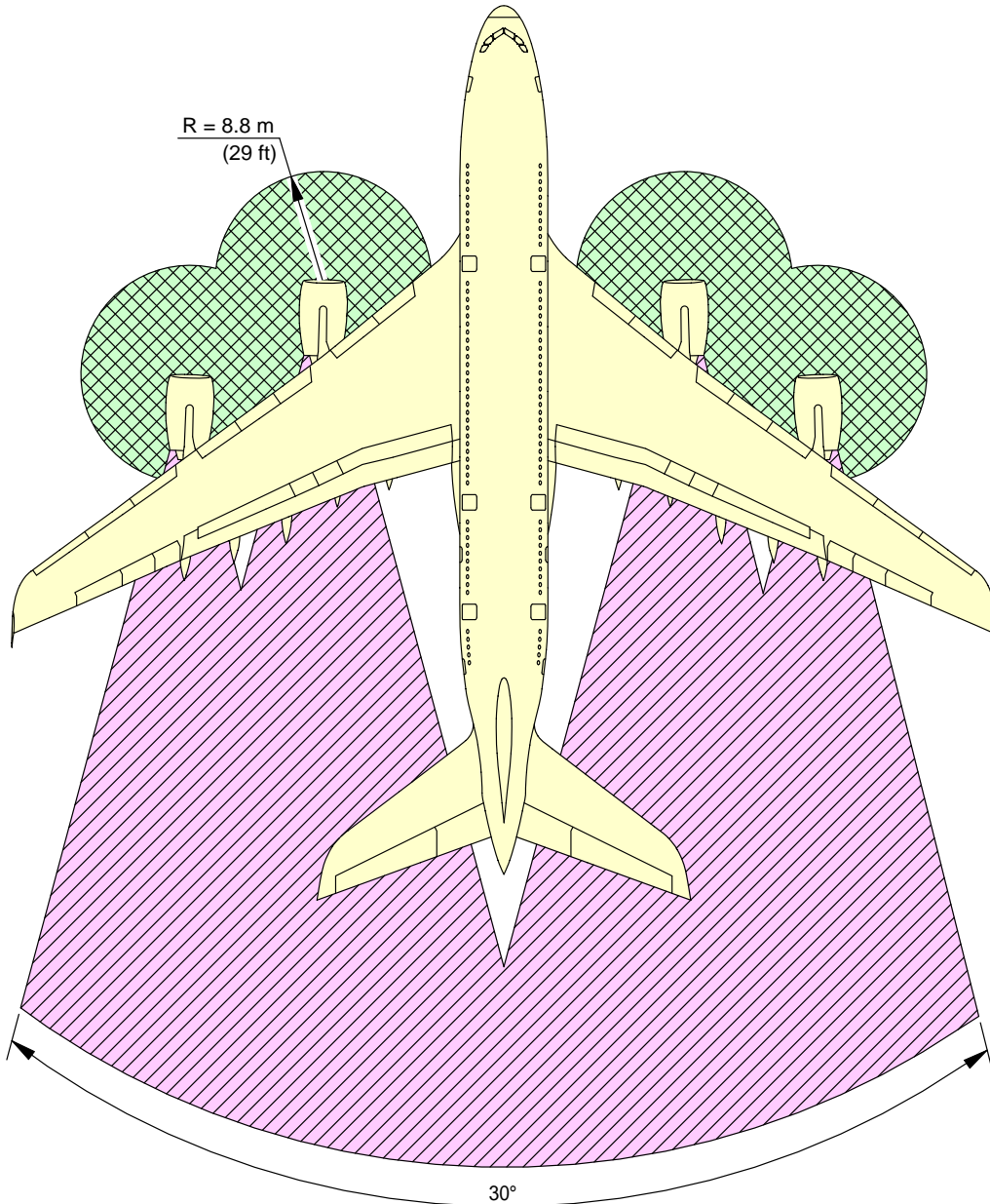

NOTE:



INTAKE SUCTION DANGER AREA MAX TAKE-OFF POWER



EXHAUST DANGER AREA



L_AC_060302_1_0010101_01_01

Danger Areas of the Engines
Max Take-Off Power - TRENT 900 Engines
FIGURE-6-3-2-991-001-A01

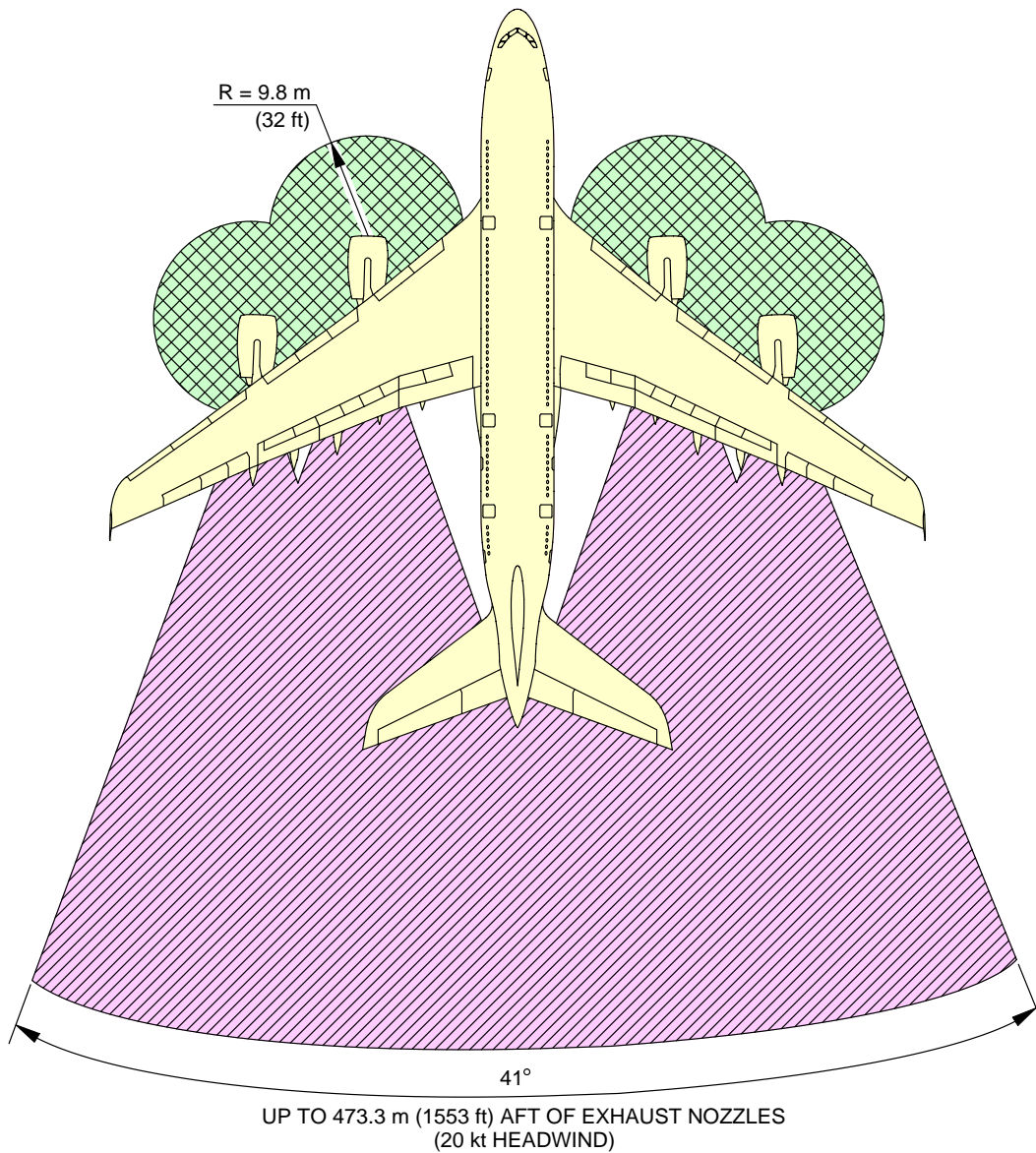
****ON A/C A380-800**



NOTE:

-  INTAKE SUCTION DANGER AREA
-  EXHAUST DANGER AREA

L_AC_060302_1_0020101_01_02

Danger Areas of the Engines
Max Take-Off Power - GP 7200 Engines
FIGURE-6-3-2-991-002-A01

6-3-3 Danger Areas of the Engines - Breakaway Power

****ON A/C A380-800**

Danger Areas of the Engines - Breakaway Power

1. This section gives danger areas of the engines at breakaway power.

****ON A/C A380-800**

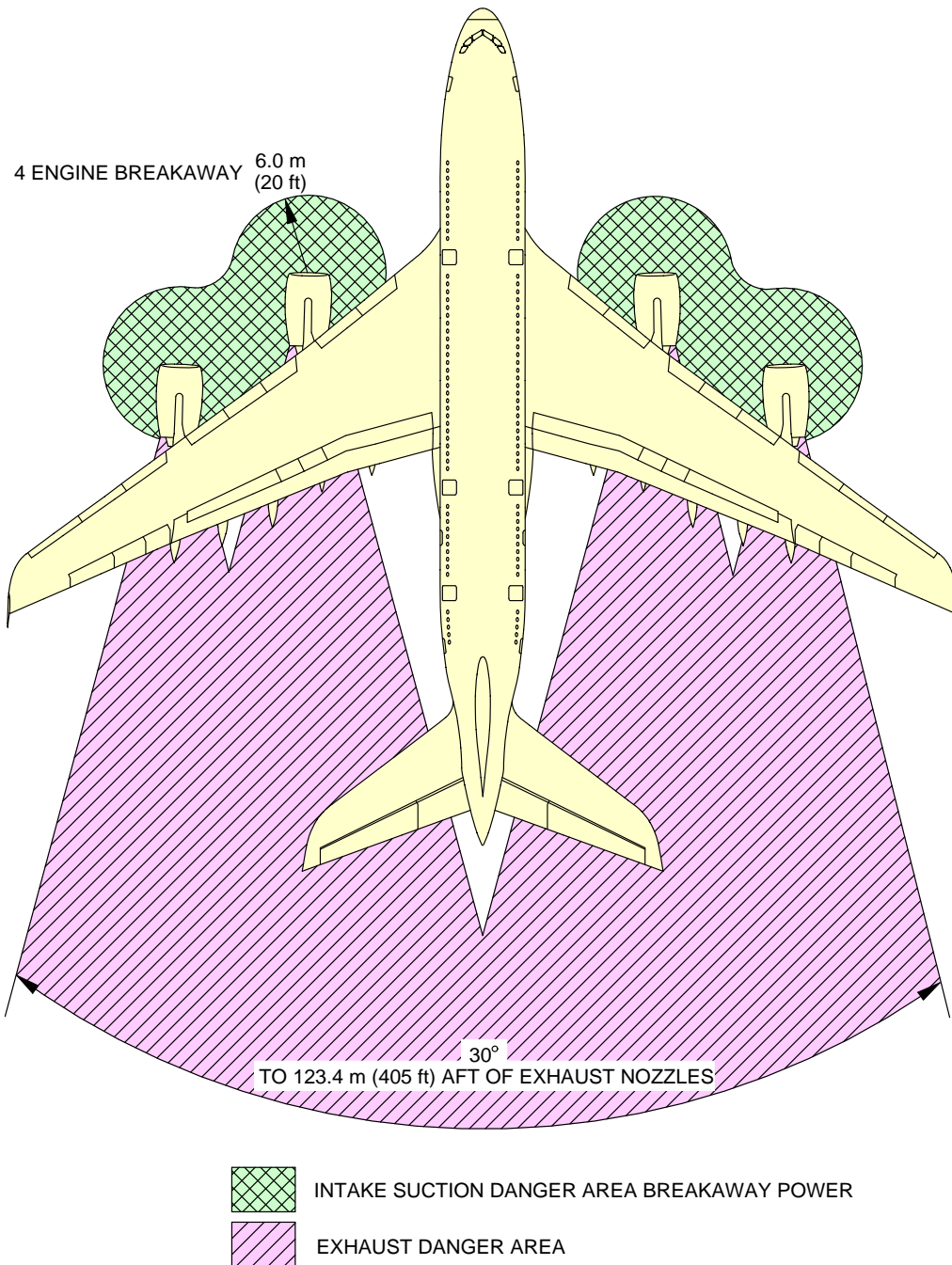

deh0001514

L_AC_060303_1_0010101_01_00

Danger Areas of the Engines
Breakaway Power - TRENT 900 Engines
FIGURE-6-3-3-991-001-A01

****ON A/C A380-800**

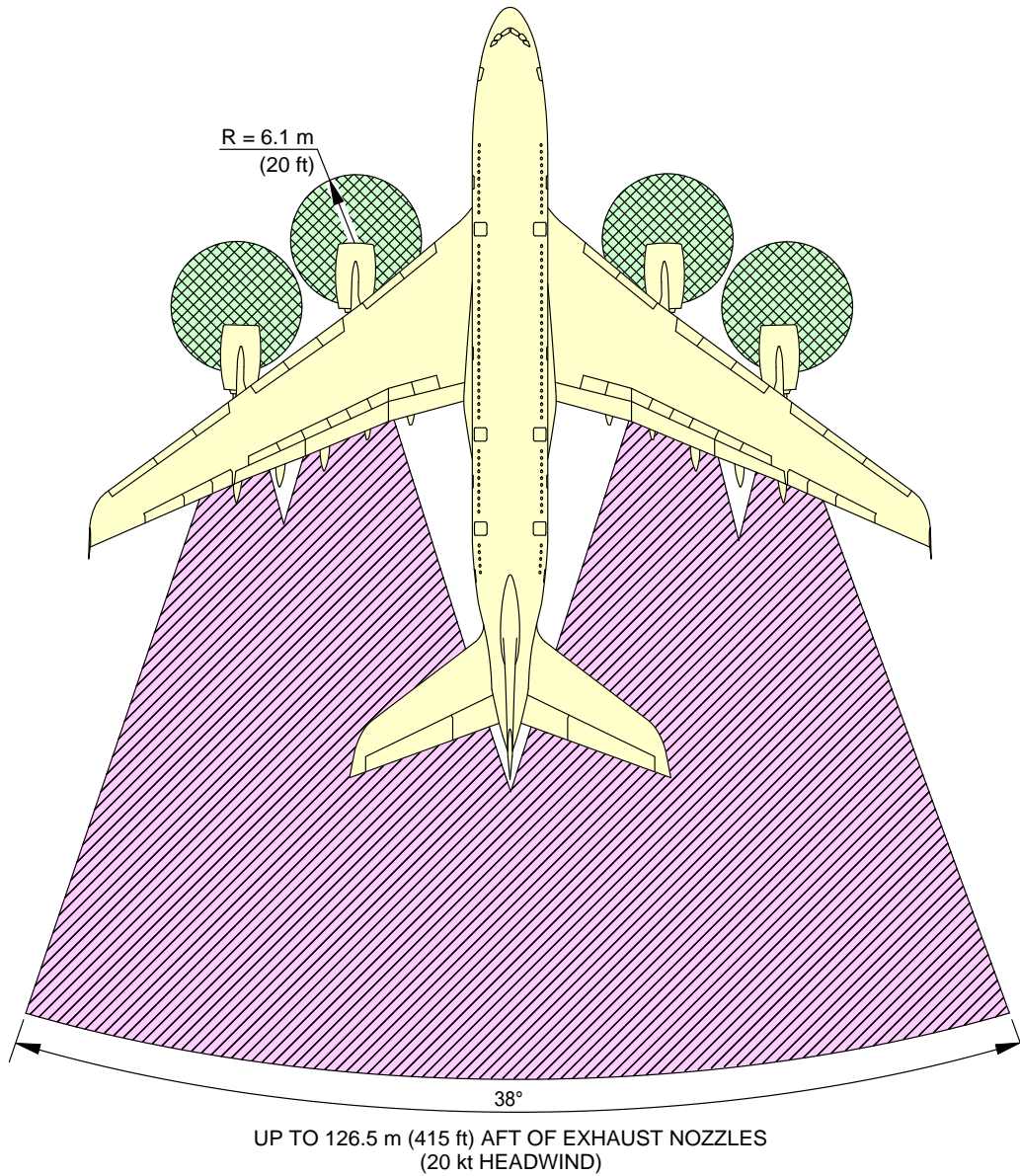

NOTE:



INTAKE SUCTION DANGER AREA



EXHAUST DANGER AREA

L_AC_060303_1_0020101_01_02

Danger Areas of the Engines
Breakaway Power - GP 7200 Engines
FIGURE-6-3-3-991-002-A01

6-4-1 APU Exhaust Velocities and Temperatures

****ON A/C A380-800**

APU Exhaust Velocities and Temperatures - ECS Conditions

1. This section provides APU exhaust velocities and temperatures in max. ECS conditions.

****ON A/C A380-800**

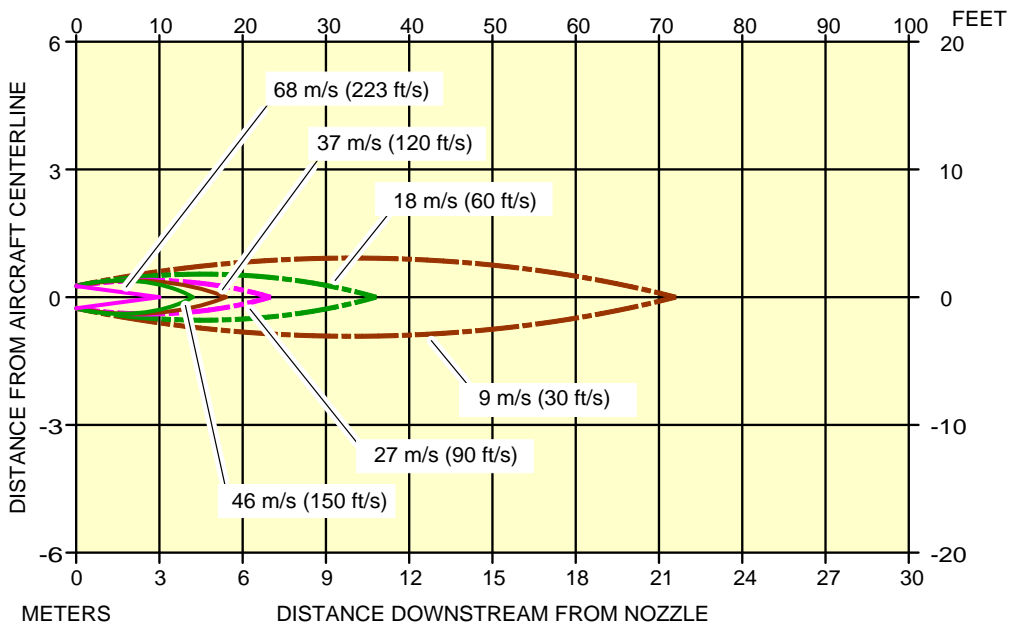
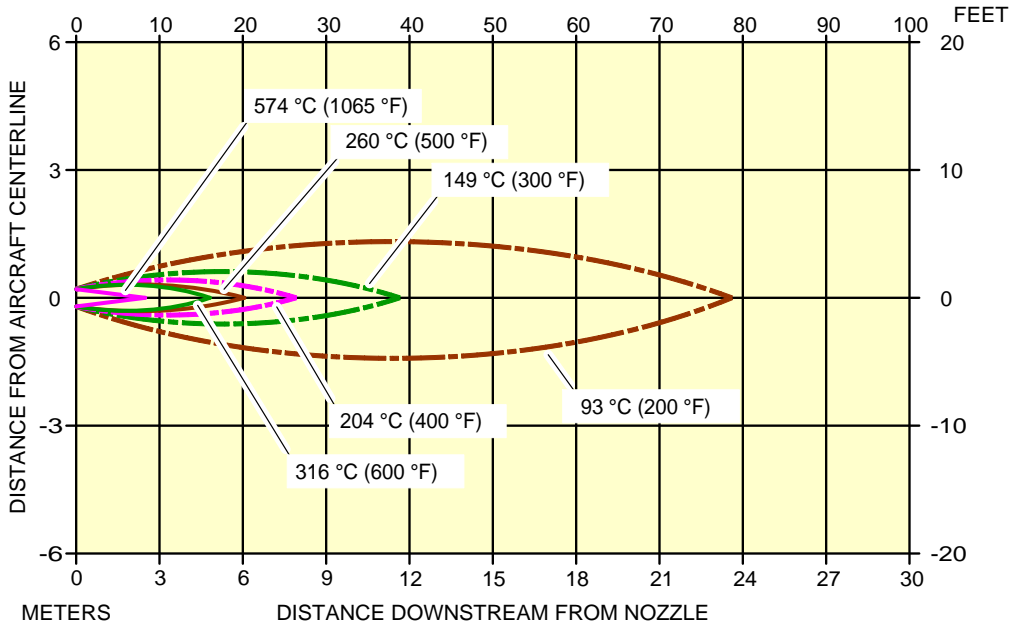

NOTE: THE DATA GIVEN IS BASED ON THE FOLLOWING ASSUMPTIONS:
 -SEA LEVEL STATIC CONDITIONS
 -ISA + 23 °C (73 °F)
 -NO WIND

L_AC_060401_1_0010101_01_00

APU Exhaust Velocities and Temperatures
 Max. ECS Conditions
 FIGURE-6-4-1-991-001-A01

6-4-2 APU Exhaust Velocities and Temperatures - MES Conditions****ON A/C A380-800**APU Exhaust Velocities and Temperatures - MES Conditions

1. This section gives the APU exhaust velocities and temperatures in MES conditions.

****ON A/C A380-800**

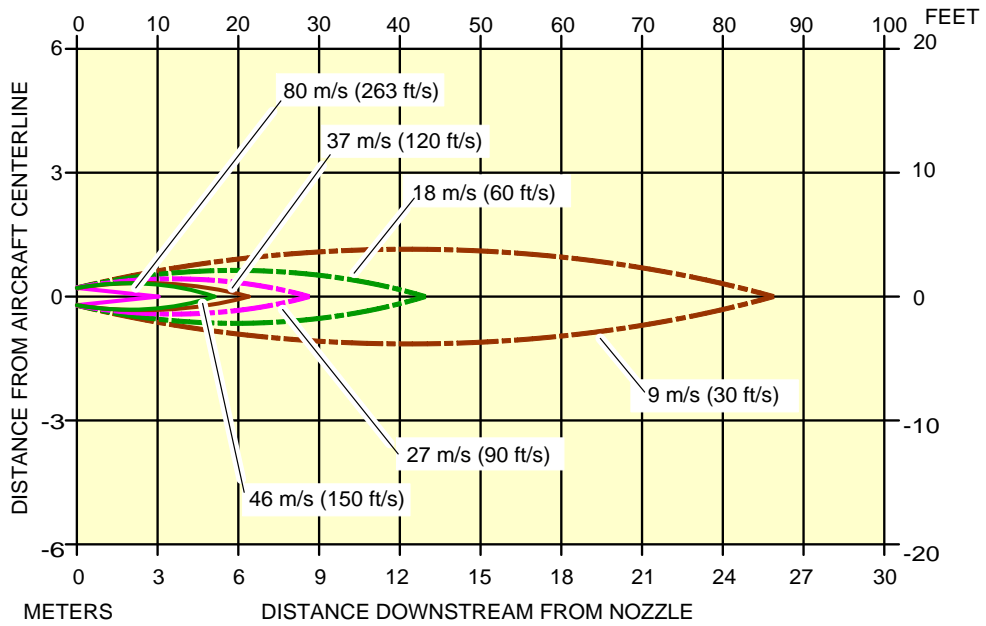
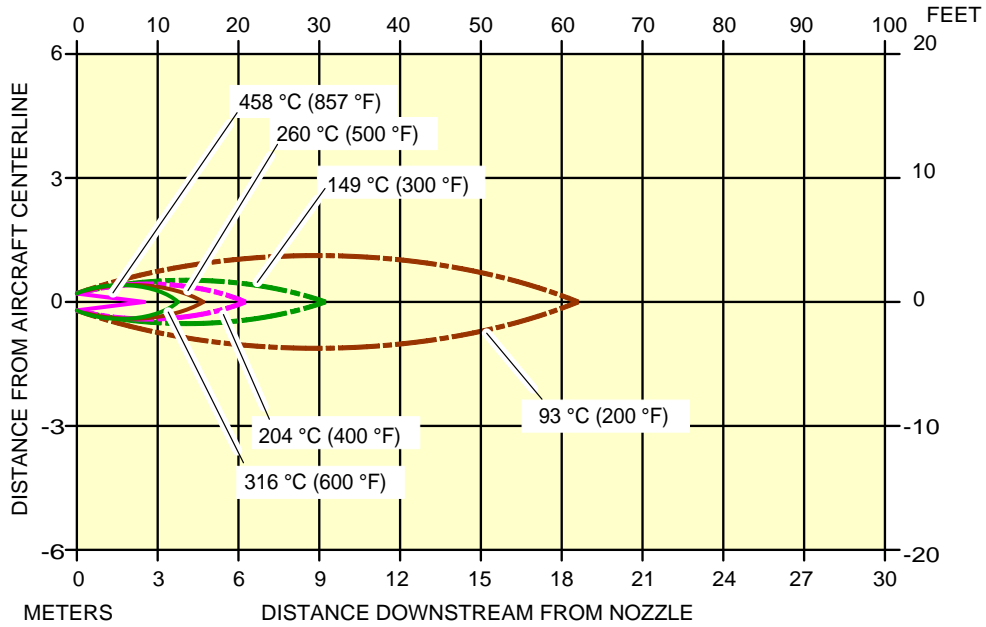

NOTE: THE DATA GIVEN IS BASED ON THE FOLLOWING ASSUMPTIONS:

- SEA LEVEL STATIC CONDITIONS
- ISA + 23 °C (73 °F)
- NO WIND

L_AC_060402_1_0010101_01_00

APU Exhaust Velocities and Temperatures
MES Conditions
FIGURE-6-4-2-991-001-A01

PAVEMENT DATA**7-1-0 General Information******ON A/C A380-800**General Information

1. A brief description of the pavement charts that follow will help in airport planning.

To aid in the interpolation between the discrete values shown, each aircraft configuration is shown with a minimum range of five loads on the Main Landing Gear (MLG).

All curves on the charts represent data at a constant specified tire pressure with:

- The aircraft loaded to the Maximum Ramp Weight (MRW),
- The CG at its maximum permissible aft position.

Pavement requirements for commercial aircraft are derived from the static analysis of loads imposed on the MLG struts.

Landing Gear Footprint:

Section 07-02-00 presents basic data on the landing gear footprint configuration, MRW and tire sizes and pressures.

Maximum Pavement Loads:

Section 07-03-00 shows maximum vertical and horizontal pavement loads for certain critical conditions at the tire-ground interfaces.

Landing Gear Loading on Pavement:

The landing gear loading on pavement curves are no longer provided in section 07-04-00 since the relationship between the aircraft weight, center of gravity and landing gear loading on the pavement is not strictly linear and can hardly be presented in chart format.

The maximum vertical and horizontal pavement loads for some critical conditions at the tire-ground interfaces can be found in section 07-03-00 for all the operational weight variants of the aircraft.

For questions regarding landing gear loading on pavement, contact Airbus.

Flexible Pavement Requirements - US Army Corps of Engineers Design Method:

The flexible pavement requirements curves as per as US Army Corps of Engineers Design Method are no longer provided in section 07-05-00 since the corresponding data is available through free software.

Sections 07-02-00 and 07-03-00 provide all the inputs data required for the use of such software.

For questions regarding flexible pavement requirements, contact Airbus.

Flexible Pavement Requirements - LCN Conversion Method:

The Load Classification Number (LCN) curves are no longer provided in section 07-06-00 since the LCN system for reporting pavement strength is obsolete, having been replaced by the ICAO recommended ACN/PCN system in 1983 and ACR/PCR system in 2020.

For questions regarding the LCN system, contact Airbus.

Rigid Pavement Requirements - PCA (Portland Cement Association) Design Method:

The rigid pavement requirements curves as per as Portland Cement Association Design Method are no longer provided in section 07-07-00 since the corresponding data is available through free software.

Sections 07-02-00 and 07-03-00 provide all the inputs data required for the use of such software.

For questions regarding rigid pavement requirements, contact Airbus.

Rigid Pavement Requirements - LCN Conversion:

The Load Classification Number (LCN) curves are no longer provided in section 07-08-00 since the LCN system for reporting pavement strength is obsolete, having been replaced by the ICAO recommended ACN/PCN system in 1983 and ACR/PCR system in 2020.

For questions regarding the LCN system, contact Airbus.

ACN/PCN Reporting System:

Section 07-09-00 provides ACN data prepared according to the ACN/PCN system as referenced in ICAO Annex 14, "Aerodromes", Volume 1 "Aerodrome Design and Operations".

Eighth Edition July 2018, incorporating Amendments 1 to 14 and ICAO doc 9157, "Aerodrome Design Manual", part 3 "Pavements" Second Edition 1983.

The ACN/PCN system is applicable until November 2024.

ACN is the Aircraft Classification Number and PCN is the corresponding Pavement Classification Number.

An aircraft having an ACN equal to or less than the PCN can operate without restriction on the pavement.

Numerically the ACN is two times the derived single wheel load expressed in thousands of kilograms.

The derived single wheel load is defined as the load on a single tire inflated to 1.25 MPa (181 psi) that would have the same pavement requirements as the aircraft.

Computationally the ACN/PCN system uses PCA program PDILB for rigid pavements and S-77-1 for flexible pavements to calculate ACN values.

The Airport Authority must decide on the method of pavement analysis.
The results of their evaluation should be reported using the following format:

PCN			
PAVEMENT TYPE	SUBGRADE CATEGORY	TIRE PRESSURE CATEGORY	EVALUATION METHOD
R - Rigid	A - High	W - No pressure limit	T - Technical
F - Flexible	B - Medium	X - High pressure limited to 1.75 MPa (254 psi)	U - Using aircraft
	C - Low	Y - Medium pressure limited to 1.25 MPa (181 psi)	
	D - Ultra low	Z - Low pressure limited to 0.5 MPa (73 psi)	

Section 07-09-00 shows the aircraft ACN values.

For flexible pavements, the four subgrade categories (CBR) are:

A - High strength	CBR 15
B - Medium strength	CBR 10
C - Low strength	CBR 6
D - Ultra low strength	CBR 3

For rigid pavements, the four subgrade categories (k) are:

A - High strength	k = 150 MN/m ³ (550 pci)
B - Medium strength	k = 80 MN/m ³ (300 pci)
C - Low strength	k = 40 MN/m ³ (150 pci)
D - Ultra low strength	k = 20 MN/m ³ (75 pci)

ACR/PCR Reporting System:

Section 07-10-00 provides ACR data prepared according to the ACR/PCR system as referenced in ICAO Annex 14, "Aerodromes", Volume 1 "Aerodrome Design and Operations".

Ninth Edition November 2020, incorporating Amendments 1 to 15 and ICAO doc 9157, "Aerodrome Design Manual", part 3 "Pavements" Third Edition 2020.

The ACR/PCR system is effective from November 2020 and will be applicable in November 2024.

ACR is the Aircraft Classification Rating and PCR is the corresponding Pavement Classification Rating.

An aircraft having an ACR equal to or less than the PCR can operate without restriction on the pavement.

Numerically the ACR is two times the derived single wheel load expressed in hundreds of kilograms.

The derived single wheel load is defined as the load on a single tire inflated to 1.50 Mpa (218 psi) that would have the same pavement requirements as the aircraft.

Computationally the ACR/PCR system relies on the Linear Elastic Analysis (LEA). The ACR are computed using the official ICAO-ACR software.

States may develop their own methods for PCR determination, consistent with the overall parameters of the ACR/PCR method.

The results of their evaluation should be reported using the following format:

PCR			
PAVEMENT TYPE	SUBGRADE CATEGORY	TIRE PRESSURE CATEGORY	EVALUATION METHOD
R - Rigid	A - High	W - No pressure limit	T - Technical
F - Flexible	B - Medium	X - High pressure limited to 1.75 MPa (254 psi)	U - Using aircraft
	C - Low	Y - Medium pressure limited to 1.25 MPa (181 psi)	
	D - Ultra low	Z - Low pressure limited to 0.5 MPa (73 psi)	

Section 07-10-00 shows the aircraft ACR values.

For flexible and rigid pavements, the four subgrade categories are defined based on the subgrade modulus of elasticity (E):

- | | |
|------------------------|--------------------------|
| A - High strength | E = 200 MPa (29 008 psi) |
| B - Medium strength | E = 120 MPa (17 405 psi) |
| C - Low strength | E = 80 MPa (11 603 psi) |
| D - Ultra low strength | E = 50 MPa (7 252 psi) |

7-2-0 Landing Gear Footprint

****ON A/C A380-800**

Landing Gear Footprint

1. This section provides data about the landing gear footprint in relation with the aircraft Maximum Ramp Weight (MRW) and tire sizes and pressures.

The landing-gear footprint information is given for all the operational weight variants of the aircraft.

****ON A/C A380-800**

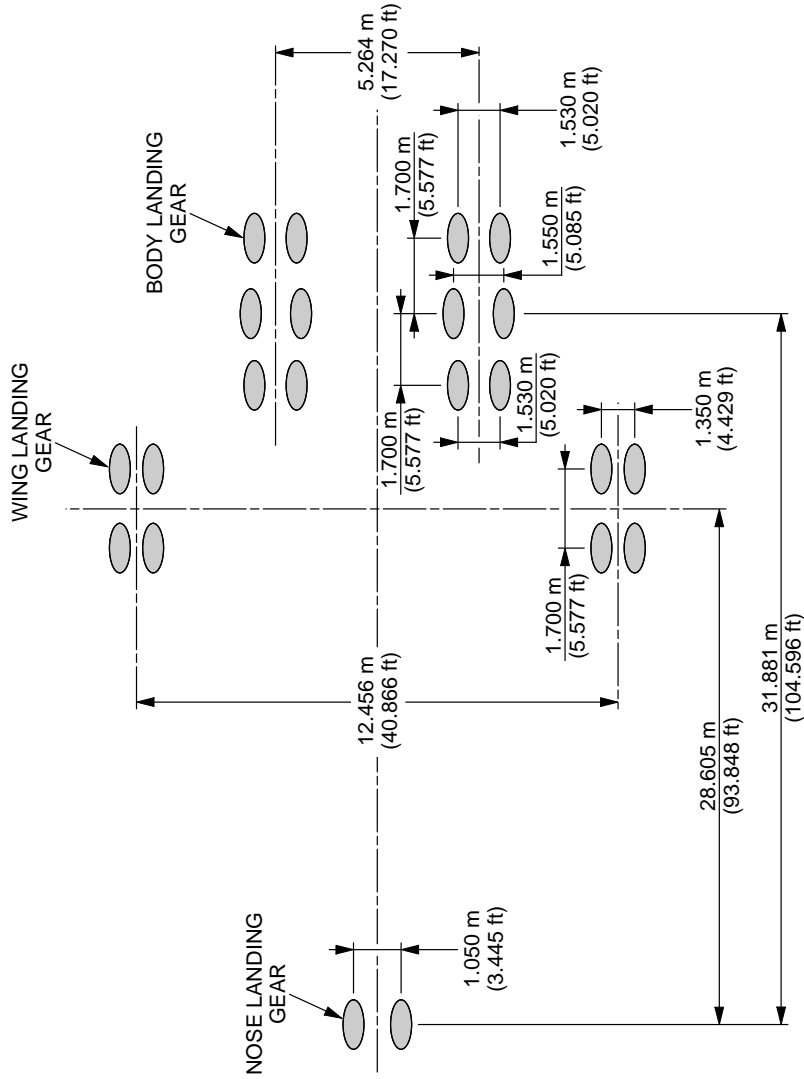

L_AC_070200_1_0030101_01_01

Landing Gear Footprint
(Sheet 1 of 2)
FIGURE-7-2-0-991-003-A01

** ON A/C A380-800

WEIGHT VARIANT	MAXIMUM RAMP WEIGHT	PERCENTAGE OF WEIGHT ON MAIN GEAR GROUP	NOSE GEAR TIRE SIZE	NOSE GEAR TIRE PRESSURE	WING GEAR TIRE SIZE	WING GEAR TIRE PRESSURE	BODY GEAR TIRE SIZE	BODY GEAR TIRE PRESSURE
WV000	562 000 kg (1 239 000 lb)	95.1%	1 270x455 R22 32PR OR 50x20 R22 34PR	14.1 bar (205 psi)	1 400x530 R23 40PR	15 bar (218 psi)	1 400x530 R23 40PR	15 bar (218 psi)
WV001	512 000 kg (1 128 775 lb)	95.1%	1 270x455 R22 32PR OR 50x20 R22 34PR	14.1 bar (205 psi)	1 400x530 R23 40PR	14 bar (203 psi)	1 400x530 R23 40PR	14 bar (203 psi)
WV002	571 000 kg (1 258 850 lb)	94.3%	1 270x455 R22 32PR OR 50x20 R22 34PR	14.1 bar (205 psi)	1 400x530 R23 40PR	15 bar (218 psi)	1 400x530 R23 40PR	15 bar (218 psi)
WV003	512 000 kg (1 128 775 lb)	95.1%	1 270x455 R22 32PR OR 50x20 R22 34PR	14.1 bar (205 psi)	1 400x530 R23 40PR	14 bar (203 psi)	1 400x530 R23 40PR	14 bar (203 psi)
WV004	562 000 kg (1 239 000 lb)	95.1%	1 270x455 R22 32PR OR 50x20 R22 34PR	14.1 bar (205 psi)	1 400x530 R23 40PR	15 bar (218 psi)	1 400x530 R23 40PR	15 bar (218 psi)
WV005	562 000 kg (1 239 000 lb)	95.1%	1 270x455 R22 32PR OR 50x20 R22 34PR	14.1 bar (205 psi)	1 400x530 R23 40PR	15 bar (218 psi)	1 400x530 R23 40PR	15 bar (218 psi)
WV006	575 000 kg (1 267 650 lb)	94.4%	50x20 R22 34PR	14.1 bar (205 psi)	1 400x530 R23 40PR	15 bar (218 psi)	1 400x530 R23 40PR	15 bar (218 psi)
WV007	492 000 kg (1 084 675 lb)	95.1%	1 270x455 R22 32PR OR 50x20 R22 34PR	14.1 bar (205 psi)	1 400x530 R23 40PR	14 bar (203 psi)	1 400x530 R23 40PR	14 bar (203 psi)
WV008	577 000 kg (1 272 075 lb)	94.3%	50x20 R22 34PR	14.1 bar (205 psi)	1 400x530 R23 40PR	15 bar (218 psi)	1 400x530 R23 40PR	15 bar (218 psi)
WV009	512 000 kg (1 128 775 lb)	95.1%	1 270x455 R22 32PR OR 50x20 R22 34PR	14.1 bar (205 psi)	1 400x530 R23 40PR	14 bar (203 psi)	1 400x530 R23 40PR	14 bar (203 psi)
WV010	482 000 kg (1 062 625 lb)	95.1%	1 270x455 R22 32PR OR 50x20 R22 34PR	14.1 bar (205 psi)	1 400x530 R23 40PR	14 bar (203 psi)	1 400x530 R23 40PR	14 bar (203 psi)
WV011	577 000 kg (1 272 075 lb)	94.3%	50x20 R22 34PR	14.1 bar (205 psi)	1 400x530 R23 40PR	15 bar (218 psi)	1 400x530 R23 40PR	15 bar (218 psi)
WV012	571 000 kg (1 258 850 lb)	94.3%	1 270x455 R22 32PR OR 50x20 R22 34PR	14.1 bar (205 psi)	1 400x530 R23 40PR	15 bar (218 psi)	1 400x530 R23 40PR	15 bar (218 psi)
WV013	494 000 kg (1 089 075 lb)	95.1%	1 270x455 R22 32PR OR 50x20 R22 34PR	14.1 bar (205 psi)	1 400x530 R23 40PR	14 bar (203 psi)	1 400x530 R23 40PR	14 bar (203 psi)
WV014	574 000 kg (1 265 450 lb)	94.3%	1 270x455 R22 32PR OR 50x20 R22 34PR	14.1 bar (205 psi)	1 400x530 R23 40PR	15 bar (218 psi)	1 400x530 R23 40PR	15 bar (218 psi)

L_AC_070200_1_0030102_01_03

Landing Gear Footprint
(Sheet 2 of 2)
FIGURE-7-2-0-991-003-A01

7-3-0 Maximum Pavement Loads****ON A/C A380-800**Maximum Pavement Loads

1. This section provides maximum vertical and horizontal pavement loads for some critical conditions at the tire-ground interfaces.

The maximum pavement loads are given for all the operational weight variants of the aircraft.

****ON A/C A380-800**

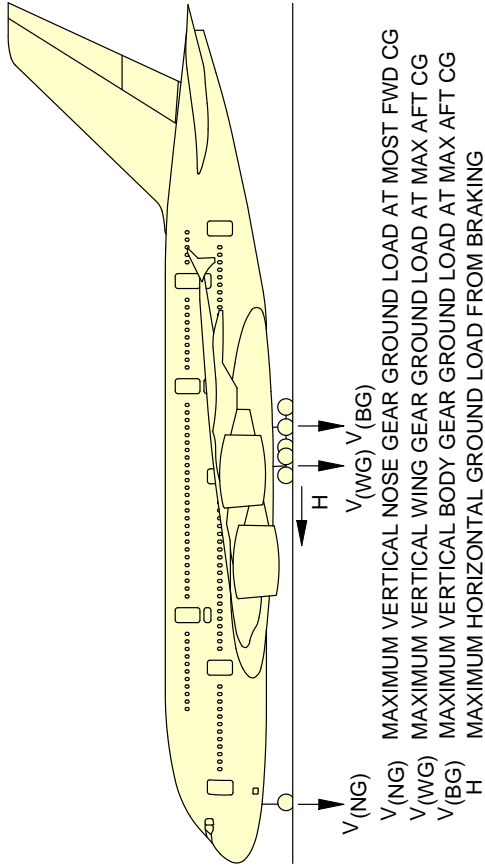

1	2	3		4		5		6		7	
		WEIGHT VARIANT	MAXIMUM RAMP WEIGHT	STATIC LOAD AT MOST FWD CG	STATIC BRKING AT 10 ft/s ² DECELERATION	STATIC LOAD AT MAX AFT CG	STATIC LOAD AT 10 ft/s ² DECELERATION	STATIC LOAD AT MAX AFT CG	STATIC LOAD AT 10 ft/s ² DECELERATION	STEADY BRKING AT 10 ft/s ² DECELERATION	AT INSTANTANEOUS BRKING COEFFICIENT = 0.8
WV000	562 000 kg (1 239 000 lb)	39 830 kg (87 800 lb)	37.5 % MAC (a)	69 430 kg (153 075 lb)	106 920 kg (235 725 lb)	43 % MAC (a)	160 380 kg (353 575 lb)	43 % MAC (a)	34 930 kg (77 025 lb)	85 540 kg (188 575 lb)	
WV001	512 000 kg (1 128 775 lb)	39 760 kg (87 675 lb)	35.81 % MAC (a)	66 730 kg (147 125 lb)	97 410 kg (214 750 lb)	43 % MAC (a)	146 110 kg (322 125 lb)	43 % MAC (a)	31 830 kg (70 175 lb)	77 930 kg (171 800 lb)	
WV002	571 000 kg (1 258 850 lb)	39 780 kg (87 700 lb)	37.8 % MAC (a)	69 850 kg (154 000 lb)	107 720 kg (237 475 lb)	41 % MAC (a)	161 570 kg (356 200 lb)	41 % MAC (a)	35 490 kg (78 250 lb)	86 170 kg (189 975 lb)	
WV003	512 000 kg (1 128 775 lb)	39 760 kg (87 675 lb)	35.81 % MAC (a)	66 730 kg (147 125 lb)	97 410 kg (214 750 lb)	43 % MAC (a)	146 110 kg (322 125 lb)	43 % MAC (a)	31 830 kg (70 175 lb)	77 930 kg (171 800 lb)	

NOTE:
 (a) LOADS CALCULATED USING AIRCRAFT AT MRW
 (b) BRAKED WING GEAR
 (c) BRAKED BODY GEAR

L_AC_070300_1_0060101_01_00

Maximum Pavement Loads
 (Sheet 1 of 3)
 FIGURE-7-3-0-991-006-A01

** ON A/C A380-800

1	2	3		4		5		6		7	
		V (NG)		V (WG)		V (BG)		H (PER STRUT)		H (PER STRUT)	
WEIGHT VARIANT	MAXIMUM RAMP WEIGHT	STATIC LOAD AT MOST FWD CG	STATIC BRAKING AT 10 ft/s ² DECELERATION	STATIC LOAD AT MAX AFT CG	STATIC LOAD AT MAX AFT CG	STATIC LOAD AT MAX AFT CG	STEADY BRAKING AT 10 ft/s ² DECELERATION	AT INSTANTANEOUS BRAKING COEFFICIENT = 0.8	STEADY BRAKING AT 10 ft/s ² DECELERATION	AT INSTANTANEOUS BRAKING COEFFICIENT = 0.8	AT INSTANTANEOUS BRAKING COEFFICIENT = 0.8
WV004	562 000 kg (1 239 000 lb)	39 830 kg (87 800 lb) 37.5 % MAC (a)	69 430 kg (153 075 lb)	106 920 kg (235 725 lb) 43 % MAC (a)	160 380 kg (353 575 lb) 43 % MAC (a)	34 930 kg (77 025 lb) 34 930 kg (77 025 lb) 52 400 kg (115 525 lb)	85 540 kg (188 575 lb) 85 540 kg (188 575 lb) 128 310 kg (282 875 lb)	34 930 kg (77 025 lb) 52 400 kg (115 525 lb)	85 540 kg (188 575 lb) 128 310 kg (282 875 lb)	85 540 kg (188 575 lb) 128 310 kg (282 875 lb)	85 540 kg (188 575 lb) 128 310 kg (282 875 lb)
WV005	562 000 kg (1 239 000 lb)	39 830 kg (87 800 lb) 37.5 % MAC (a)	69 430 kg (153 075 lb)	106 920 kg (235 725 lb) 43 % MAC (a)	160 380 kg (353 575 lb) 43 % MAC (a)	34 930 kg (77 025 lb) 34 930 kg (77 025 lb) 52 400 kg (115 525 lb)	85 540 kg (188 575 lb) 85 540 kg (188 575 lb) 128 310 kg (282 875 lb)	34 930 kg (77 025 lb) 52 400 kg (115 525 lb)	85 540 kg (188 575 lb) 128 310 kg (282 875 lb)	85 540 kg (188 575 lb) 128 310 kg (282 875 lb)	85 540 kg (188 575 lb) 128 310 kg (282 875 lb)
WV006	575 000 kg (1 267 650 lb)	40 190 kg (88 600 lb) 37.74 % MAC (a)	70 480 kg (155 375 lb)	108 590 kg (239 400 lb) 41.26 % MAC (a)	162 880 kg (359 100 lb) 41.26 % MAC (a)	35 740 kg (78 800 lb) 35 740 kg (78 800 lb) 53 610 kg (118 200 lb)	86 870 kg (191 525 lb) 86 870 kg (191 525 lb) 130 310 kg (287 275 lb)	35 740 kg (78 800 lb) 53 610 kg (118 200 lb)	86 870 kg (191 525 lb) 130 310 kg (287 275 lb)	86 870 kg (191 525 lb) 130 310 kg (287 275 lb)	86 870 kg (191 525 lb) 130 310 kg (287 275 lb)
WV007	492 000 kg (1 084 675 lb)	39 700 kg (87 525 lb) 35.06 % MAC (a)	65 610 kg (144 650 lb)	93 600 kg (206 350 lb) 43 % MAC (a)	140 410 kg (309 550 lb) 43 % MAC (a)	30 580 kg (67 425 lb) 30 580 kg (67 425 lb) 45 880 kg (101 150 lb)	74 880 kg (165 100 lb) 74 880 kg (165 100 lb) 112 320 kg (247 625 lb)	30 580 kg (67 425 lb) 45 880 kg (101 150 lb)	74 880 kg (165 100 lb) 112 320 kg (247 625 lb)	74 880 kg (165 100 lb) 112 320 kg (247 625 lb)	74 880 kg (165 100 lb) 112 320 kg (247 625 lb)
WV008	577 000 kg (1 272 075 lb)	40 190 kg (88 600 lb) 37.8 % MAC (a)	70 590 kg (155 625 lb)	108 850 kg (239 975 lb) 41 % MAC (a)	163 270 kg (359 950 lb) 41 % MAC (a)	35 870 kg (79 075 lb) 35 870 kg (79 075 lb) 53 800 kg (118 600 lb)	87 080 kg (191 975 lb) 87 080 kg (191 975 lb) 130 620 kg (287 950 lb)	35 870 kg (79 075 lb) 53 800 kg (118 600 lb)	87 080 kg (191 975 lb) 130 620 kg (287 950 lb)	87 080 kg (191 975 lb) 130 620 kg (287 950 lb)	87 080 kg (191 975 lb) 130 620 kg (287 950 lb)
WV009	512 000 kg (1 128 775 lb)	39 720 kg (87 575 lb) 35.83 % MAC (a)	66 690 kg (147 025 lb)	97 410 kg (214 750 lb) 43 % MAC (a)	146 110 kg (322 125 lb) 43 % MAC (a)	31 830 kg (70 175 lb) 31 830 kg (70 175 lb) 47 740 kg (105 250 lb)	77 930 kg (171 800 lb) 77 930 kg (171 800 lb) 116 890 kg (257 700 lb)	31 830 kg (70 175 lb) 47 740 kg (105 250 lb)	77 930 kg (171 800 lb) 116 890 kg (257 700 lb)	77 930 kg (171 800 lb) 116 890 kg (257 700 lb)	77 930 kg (171 800 lb) 116 890 kg (257 700 lb)
WV010	482 000 kg (1 062 625 lb)	39 680 kg (87 500 lb) 34.65 % MAC (a)	65 070 kg (143 450 lb)	91 700 kg (202 175 lb) 43 % MAC (a)	137 550 kg (303 250 lb) 43 % MAC (a)	29 960 kg (66 050 lb) 29 960 kg (66 050 lb) 44 940 kg (99 075 lb)	73 360 kg (161 725 lb) 73 360 kg (161 725 lb) 110 040 kg (242 600 lb)	29 960 kg (66 050 lb) 44 940 kg (99 075 lb)	73 360 kg (161 725 lb) 110 040 kg (242 600 lb)	73 360 kg (161 725 lb) 110 040 kg (242 600 lb)	73 360 kg (161 725 lb) 110 040 kg (242 600 lb)
WV011	577 000 kg (1 272 075 lb)	40 190 kg (88 600 lb) 37.8 % MAC (a)	70 590 kg (155 625 lb)	108 850 kg (239 975 lb) 41 % MAC (a)	163 270 kg (359 950 lb) 41 % MAC (a)	35 870 kg (79 075 lb) 35 870 kg (79 075 lb) 53 800 kg (118 600 lb)	87 080 kg (191 975 lb) 87 080 kg (191 975 lb) 130 620 kg (287 950 lb)	35 870 kg (79 075 lb) 53 800 kg (118 600 lb)	87 080 kg (191 975 lb) 130 620 kg (287 950 lb)	87 080 kg (191 975 lb) 130 620 kg (287 950 lb)	87 080 kg (191 975 lb) 130 620 kg (287 950 lb)
WV012	571 000 kg (1 258 850 lb)	39 780 kg (87 700 lb) 37.8 % MAC (a)	69 850 kg (154 000 lb)	107 720 kg (237 475 lb) 41 % MAC (a)	161 570 kg (356 200 lb) 41 % MAC (a)	35 490 kg (78 250 lb) 35 490 kg (78 250 lb) 53 240 kg (117 375 lb)	86 170 kg (189 975 lb) 86 170 kg (189 975 lb) 129 260 kg (284 975 lb)	35 490 kg (78 250 lb) 53 240 kg (117 375 lb)	86 170 kg (189 975 lb) 129 260 kg (284 975 lb)	86 170 kg (189 975 lb) 129 260 kg (284 975 lb)	86 170 kg (189 975 lb) 129 260 kg (284 975 lb)

NOTE:
 (a) LOADS CALCULATED USING AIRCRAFT AT MRW
 (b) BRAKED WING GEAR
 (c) BRAKED BODY GEAR

L_AC_070300_1_0060102_01_03

Maximum Pavement Loads
 (Sheet 2 of 3)
 FIGURE-7-3-0-991-006-A01

**ON A/C A380-800

1	2	3		4		5		6		7	
		V(NG)		V(NG)		V(WG) (PER STRUT)		V(BG) (PER STRUT)		H (PER STRUT)	
WEIGHT VARIANT	MAXIMUM RAMP WEIGHT	STATIC LOAD AT MOST FWD CG	STATIC BRAKING AT 10 ft/s ² DECELERATION	STATIC LOAD AT MAX AFT CG	STATIC LOAD AT MAX AFT CG	STATIC LOAD AT MAX AFT CG	STATIC LOAD AT MAX AFT CG	STEADY BRAKING AT 10 ft/s ² DECELERATION	AT INSTANTANEOUS BRAKING COEFFICIENT = 0.8		
WV013	494 000 kg (1 089 075 lb)	39 740 kg (87 600 lb)	65 760 kg (144 975 lb)	93 980 kg (207 200 lb)	140 980 kg (310 800 lb)	43 % MAC (a)	43 % MAC (a)	30 710 kg (67 700 lb)	75 190 kg (165 750 lb)	(b)	(b)
WV014	574 000 kg (1 265 450 lb)	39 980 kg (88 150 lb)	70 220 kg (154 800 lb)	108 280 kg (238 725 lb)	162 420 kg (358 075 lb)	41 % MAC (a)	41 % MAC (a)	46 060 kg (101 550 lb)	112 780 kg (248 650 lb)	(c)	(c)
								35 680 kg (78 675 lb)	86 620 kg (190 975 lb)	(b)	(b)
								53 520 kg (118 000 lb)	129 940 kg (286 475 lb)	(c)	(c)

NOTE:
 (a) LOADS CALCULATED USING AIRCRAFT AT MRW
 (b) BRAKED WING GEAR
 (c) BRAKED BODY GEAR

L_AC_070300_1_0060103_01_00

Maximum Pavement Loads
 (Sheet 3 of 3)
 FIGURE-7-3-0-991-006-A01

7-4-0 Landing Gear Loading on Pavement

****ON A/C A380-800**

Landing Gear Loading on Pavement

1. The landing gear loading on pavement curves are no longer provided in section 07-04-00 since the relationship between aircraft weight, center of gravity and landing gear loading on the pavement is not strictly linear and can hardly be presented in chart format.
The maximum vertical and horizontal pavement loads for some critical conditions at the tire-ground interfaces can be found in section 07-03-00 for all the operational weight variants of the aircraft.

For questions regarding landing gear loading on pavement, contact Airbus.

7-5-0 Flexible Pavement Requirements - US Army Corps of Engineers Design Method****ON A/C A380-800**Flexible Pavement Requirements - US Army Corps of Engineers Design Method

1. The flexible pavement requirements curves as per as US Army Corps of Engineers Design Method are no longer provided in section 07-05-00 since the corresponding data is available through free software.
Sections 07-02-00 and 07-03-00 provide all the inputs data required for the use of such software.

NOTE : The US Army Corps of Engineers Design Method for flexible pavements is being progressively superseded by mechanistic-empirical design methods mostly relying on Linear Elastic Analysis (LEA).
The number of parameters considered by such methods is not suitable for a chart format and requires the use of dedicated pavement design software.

For questions regarding flexible pavement requirements, contact Airbus.

7-6-0 Flexible Pavement Requirements - LCN Conversion****ON A/C A380-800**Flexible Pavement Requirements - LCN Conversion

1. The Load Classification Number (LCN) curves are no longer provided in section 07-06-00 since the LCN system for reporting pavement strength is obsolete, having been replaced by the ICAO recommended ACN/PCN system in 1983 and ACR/PCR system in 2020.
For questions regarding the LCN system, contact Airbus.

7-7-0 Rigid Pavement Requirements - Portland Cement Association Design Method****ON A/C A380-800**Rigid Pavement Requirements - Portland Cement Association Design Method

1. The rigid pavement requirements curves as per as Portland Cement Association Design Method are no longer provided in section 07-07-00 since the corresponding data is available through free software.
Sections 07-02-00 and 07-03-00 provide all the inputs data required for the use of such software.

NOTE : The Portland Cement Association Design Method for rigid pavements is being progressively superseded by mechanistic-empirical design methods mostly relying on Finite Element Analysis (FEM).
The number of parameters considered by such methods is not suitable for a chart format and requires the use of dedicated pavement design software.

For questions regarding rigid pavement requirements, contact Airbus.

7-8-0 Rigid Pavement Requirements - LCN Conversion****ON A/C A380-800**Rigid Pavement Requirements - LCN Conversion

1. The Load Classification Number (LCN) curves are no longer provided in section 07-08-00 since the LCN system for reporting pavement strength is obsolete, having been replaced by the ICAO recommended ACN/PCN system in 1983 and ACR/PCR system in 2020.
For questions regarding the LCN system, contact Airbus.

7-9-0 ACN-PCN Reporting System - Flexible and Rigid Pavements

**ON A/C A380-800

ACN/PCN Reporting System - Flexible and Rigid Pavements

1. This section gives data about the Aircraft Classification Number (ACN) for an aircraft gross weight in relation with standard subgrade strength values for flexible and rigid pavement.
To find the ACN of an aircraft on flexible and rigid pavement, you must know the aircraft gross weight and the subgrade strength.

NOTE : An aircraft with an ACN equal to or less than the reported PCN can operate on that pavement, subject to any limitation on the tire pressure.
(Ref: ICAO Aerodrome Design Manual, Part 3, Chapter 1, Second Edition 1983).

2. Aircraft Classification Number - ACN table

The table in FIGURE 7-9-0-991-001-A provide ACN data in tabular format for all the operational weight variants of the aircraft.

As an approximation, use a linear interpolation in order to get the ACN at the required operating weight using the following equation:

$$\text{ACN} = \text{ACN min} + (\text{ACN max} - \text{ACN min}) \times (\text{Operating weight} - 300\,000 \text{ kg}) / (\text{MRW} - 300\,000 \text{ kg}).$$

Please note that the interpolation error may reach 5% to 10%.

As an approximation, use a linear interpolation in order to get the aircraft weight at the pavement PCN using the following equation:

$$\text{Operating weight} = 300\,000 \text{ kg} + (\text{MRW} - 300\,000 \text{ kg}) \times (\text{PCN} - \text{ACN min}) / (\text{ACN max} - \text{ACN min}).$$

With ACN max = ACN calculated at the MRW in the table and with ACN min = ACN calculated at 300 000 kg.

Please note that the interpolation error may reach up to 5%.

For questions or specific calculation regarding ACN/PCN Reporting System, contact Airbus.



AIRCRAFT CHARACTERISTICS - AIRPORT AND MAINTENANCE PLANNING

****ON A/C A380-800**

WEIGHT VARIANT	ALL UP MASS (kg)	LOAD ON ONE MAIN GEAR LEG (%)	TIRE PRESSURE (MPa)	ACN FOR RIGID PAVEMENT SUBGRADES-MN/m ³				ACN FOR FLEXIBLE PAVEMENT SUBGRADES-CBR			
				HIGH 150	MEDIUM 80	LOW 40	ULTRA-LOW 20	HIGH 15	MEDIUM 10	LOW 6	ULTRA-LOW 3
WV000	562 000	19 (WLG)	1.50	56	66	78	90	58	64	75	102
		28.5 (BLG)		55	68	88	110	56	62	75	106
	300 000	19 (WLG)		27	29	34	39	27	29	31	40
		28.5 (BLG)		29	29	34	42	25	27	30	40
WV001	512 000	19 (WLG)	1.40	49	57	68	79	51	56	66	90
		28.5 (BLG)		48	57	75	94	49	54	65	92
	300 000	19 (WLG)		26	29	33	38	27	28	31	40
		28.5 (BLG)		28	28	33	42	25	27	30	40
WV002	571 000	18.9 (WLG)	1.50	57	67	79	91	59	64	76	103
		28.3 (BLG)		55	69	89	111	57	63	76	107
	300 000	18.9 (WLG)		27	29	33	38	27	28	31	40
		28.3 (BLG)		28	28	34	42	25	26	30	39
WV003	512 000	19 (WLG)	1.40	49	57	68	79	51	56	66	90
		28.5 (BLG)		48	57	75	94	49	54	65	92
	300 000	19 (WLG)		26	29	33	38	27	28	31	40
		28.5 (BLG)		28	28	33	42	25	27	30	40
WV004	562 000	19 (WLG)	1.50	56	66	78	90	58	64	75	102
		28.5 (BLG)		55	68	88	110	56	62	75	106
	300 000	19 (WLG)		27	29	34	39	27	29	31	40
		28.5 (BLG)		29	29	34	42	25	27	30	40
WV005	562 000	19 (WLG)	1.50	56	66	78	90	58	64	75	102
		28.5 (BLG)		55	68	88	110	56	62	75	106
	300 000	19 (WLG)		27	29	34	39	27	29	31	40
		28.5 (BLG)		29	29	34	42	25	27	30	40
WV006	575 000	18.9 (WLG)	1.50	58	67	80	92	60	65	77	105
		28.3 (BLG)		56	69	91	113	57	63	77	108
	300 000	18.9 (WLG)		27	29	33	38	27	28	31	40
		28.3 (BLG)		28	28	34	42	25	26	30	39
WV007	492 000	19 (WLG)	1.40	46	54	64	74	49	53	62	85
		28.5 (BLG)		46	54	70	89	47	51	61	87
	300 000	19 (WLG)		26	29	33	38	27	28	31	40
		28.5 (BLG)		28	28	33	42	25	27	30	40
WV008	577 000	18.9 (WLG)	1.50	58	68	80	93	60	65	77	105
		28.3 (BLG)		56	70	91	113	58	63	77	108
	300 000	18.9 (WLG)		27	29	33	38	27	28	31	40
		28.3 (BLG)		28	28	34	42	25	26	30	39
WV009	512 000	19 (WLG)	1.40	49	57	68	79	51	56	66	90
		28.5 (BLG)		48	57	75	94	49	54	65	92
	300 000	19 (WLG)		26	29	33	38	27	28	31	40
		28.5 (BLG)		28	28	33	42	25	27	30	40

L_AC_070900_1_0010101_01_03

Aircraft Classification Number
 ACN Table (Sheet 1 of 2)
 FIGURE-7-9-0-991-001-A01



AIRCRAFT CHARACTERISTICS - AIRPORT AND MAINTENANCE PLANNING

****ON A/C A380-800**

WEIGHT VARIANT	ALL UP MASS (kg)	LOAD ON ONE MAIN GEAR LEG (%)	TIRE PRESSURE (MPa)	ACN FOR RIGID PAVEMENT SUBGRADES-MN/m³				ACN FOR FLEXIBLE PAVEMENT SUBGRADES-CBR			
				HIGH 150	MEDIUM 80	LOW 40	ULTRA-LOW 20	HIGH 15	MEDIUM 10	LOW 6	ULTRA-LOW 3
WV010	482 000	19 (WLG)	1.40	45	52	62	72	48	52	60	83
		28.5 (BLG)		45	52	68	86	45	50	59	84
	300 000	19 (WLG)		26	29	33	38	27	28	31	40
		28.5 (BLG)		28	28	33	42	25	27	30	40
WV011	577 000	18.9 (WLG)	1.50	58	68	80	93	60	65	77	105
		28.3 (BLG)		56	70	91	113	58	63	77	108
	300 000	18.9 (WLG)		27	29	33	38	27	28	31	40
		28.3 (BLG)		28	28	34	42	25	26	30	39
WV012	571 000	18.9 (WLG)	1.50	57	67	79	91	59	64	76	103
		28.3 (BLG)		55	69	89	111	57	63	76	107
	300 000	18.9 (WLG)		27	29	33	38	27	28	31	40
		28.3 (BLG)		28	28	34	42	25	26	30	39
WV013	494 000	19 (WLG)	1.40	46	54	64	75	49	53	62	86
		28.5 (BLG)		46	54	71	89	47	52	62	87
	300 000	19 (WLG)		26	29	33	38	27	28	31	40
		28.5 (BLG)		28	28	33	42	25	27	30	40
WV014	574 000	18.9 (WLG)	1.50	57	67	80	92	59	65	77	104
		28.3 (BLG)		56	69	90	112	57	63	76	107
	300 000	18.9 (WLG)		27	29	33	38	27	28	31	40
		28.3 (BLG)		28	28	34	42	25	26	30	39

L_AC_070900_1_0010102_01_01

Aircraft Classification Number
 ACN Table (Sheet 2 of 2)
 FIGURE-7-9-0-991-001-A01

7-10-0 ACR-PCR Reporting System - Flexible and Rigid Pavements****ON A/C A380-800**ACR/PCR Reporting System - Flexible and Rigid Pavements

1. The ACR/PCR system has been developed by the ICAO to overcome the deficiencies of the ACN/PCN system. Significant advances in pavement design methods had occurred since its development in the late 1970s early 1980s, leading to inconsistencies with the pavement strength rating system.

The ACR/PCR system entails new procedures for the determination of both the ACR and the PCR that are consistent with the current pavement design procedures. This allows to capture the effects of the improved characteristics of new pavement materials as well as modern landing gear configurations, thus leading to an improved accuracy.

This section gives data about the Aircraft Classification Rating (ACR) for the maximum ramp weight in relation with standard subgrade strength values for flexible and rigid pavement. To determine the ACR at other aircraft gross weight, use the official ICAO-ACR software.

NOTE : An aircraft with an ACR equal to or less than the reported PCR can operate on that pavement, subject to any limitation on the tire pressure.
(Ref: ICAO Aerodrome Design Manual, Part 3, Third Edition 2020).

2. Aircraft Classification Rating - ACR table

The table FIGURE 7-10-0-991-001-A provide ACR data in tabular format for all the operational weight variants of the aircraft.

For questions or specific calculation regarding ACR/PCR Reporting System, contact Airbus.



AIRCRAFT CHARACTERISTICS - AIRPORT AND MAINTENANCE PLANNING

****ON A/C A380-800**

WEIGHT VARIANT	ALL UP MASS (kg)	LOAD ON ONE MAIN GEAR LEG (%)	TIRE PRESSURE (MPa)	ACR FOR RIGID PAVEMENT SUBGRADES - MPa				ACR FOR FLEXIBLE PAVEMENT SUBGRADES - MPa			
				HIGH 200	MEDIUM 120	LOW 80	ULTRA-LOW 50	HIGH 200	MEDIUM 120	LOW 80	ULTRA-LOW 50
WV000	562 000	19 (WLG)	1.5	640	820	980	1 160	550	580	640	910
		28.5 (BLG)									
WV001	512 000	19 (WLG)	1.4	540	680	830	1 000	490	510	570	740
		28.5 (BLG)									
WV002	571 000	18.9 (WLG)	1.5	650	830	990	1 180	550	580	650	920
		28.3 (BLG)									
WV003	512 000	19 (WLG)	1.4	540	680	830	1 000	490	510	570	740
		28.5 (BLG)									
WV004	562 000	19 (WLG)	1.5	640	820	980	1 160	550	580	640	910
		28.5 (BLG)									
WV005	562 000	19 (WLG)	1.5	640	820	980	1 160	550	580	640	910
		28.5 (BLG)									
WV006	575 000	18.9 (WLG)	1.5	660	840	1 000	1 190	560	590	660	940
		28.3 (BLG)									
WV007	492 000	19 (WLG)	1.4	520	640	770	930	470	490	540	690
		28.5 (BLG)									
WV008	577 000	18.9 (WLG)	1.5	660	840	1 010	1 190	560	590	660	940
		28.3 (BLG)									
WV009	512 000	19 (WLG)	1.4	540	680	830	1 000	490	510	570	740
		28.5 (BLG)									
WV010	482 000	19 (WLG)	1.4	500	620	750	900	460	480	520	660
		28.5 (BLG)									
WV011	577 000	18.9 (WLG)	1.5	660	840	1 010	1 190	560	590	660	940
		28.3 (BLG)									
WV012	571 000	18.9 (WLG)	1.5	650	830	990	1 180	550	580	650	920
		28.3 (BLG)									
WV013	494 000	19 (WLG)	1.4	520	640	780	940	470	490	540	700
		28.5 (BLG)									
WV014	574 000	18.9 (WLG)	1.5	650	830	1 000	1 180	560	590	650	930
		28.3 (BLG)									

L_AC_071000_1_0010101_01_00

Aircraft Classification Rating
ACR Table
FIGURE-7-10-0-991-001-A01



SCALED DRAWINGS

8-0-0 SCALED DRAWINGS

****ON A/C A380-800**

Scaled Drawings

1. This section provides the scaled drawings.

NOTE : When printing this drawing, make sure to adjust for proper scaling.

****ON A/C A380-800**

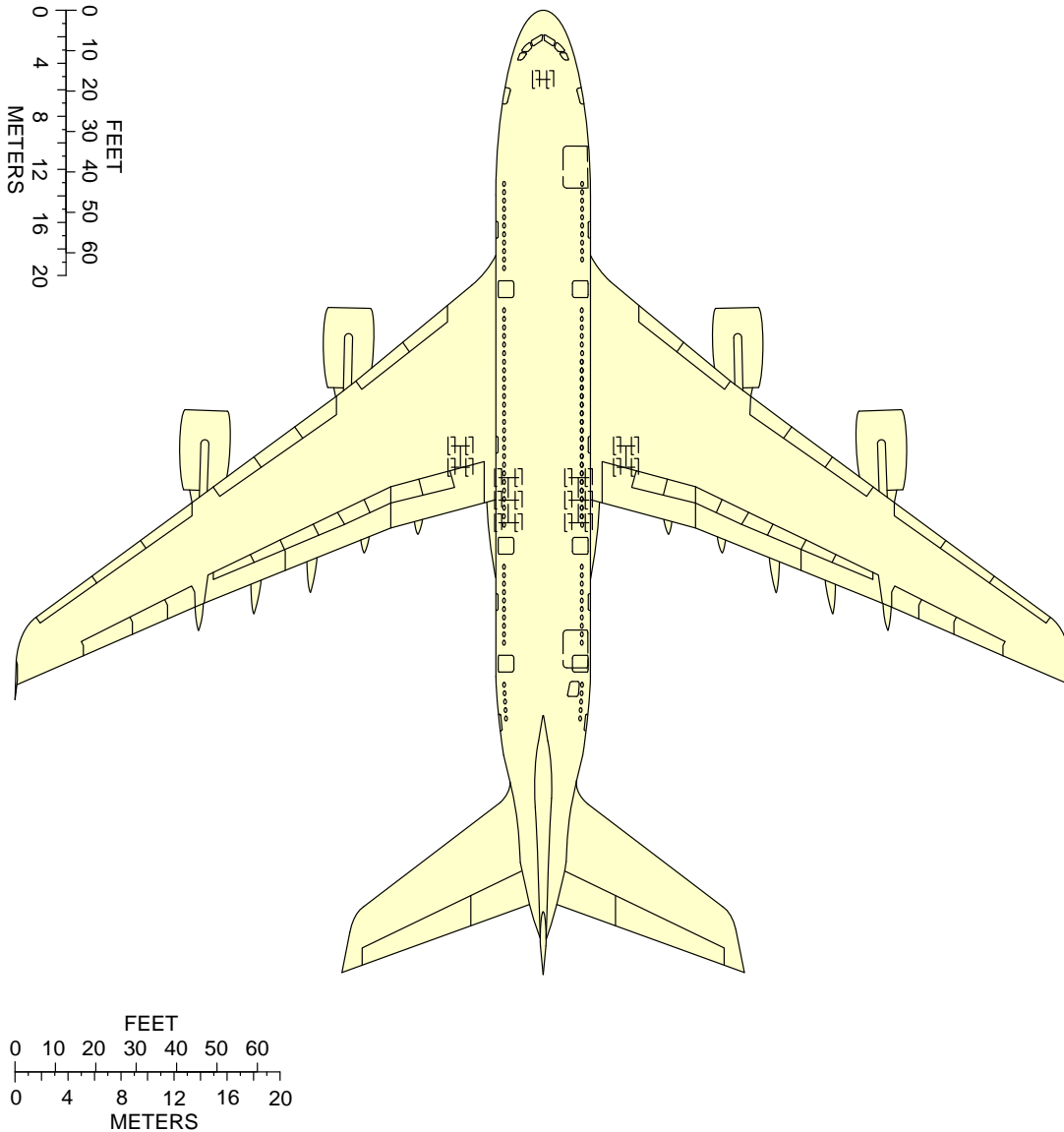

NOTE: WHEN PRINTING THIS DRAWING, MAKE SURE TO ADJUST FOR PROPER SCALING.

DB1A

L_AC_080000_1_0010101_01_01

Scaled Drawing
FIGURE-8-0-0-991-001-A01



AIRCRAFT RESCUE AND FIRE FIGHTING

10-0-0 AIRCRAFT RESCUE AND FIRE FIGHTING

****ON A/C A380-800**

Aircraft Rescue and Fire Fighting

1. Aircraft Rescue and Fire Fighting Charts

This section provides data related to aircraft rescue and fire fighting.

The figures contained in this section are the figures that are in the Aircraft Rescue and Fire Fighting Charts poster available on AIRBUSWorld and the Airbus website.

**ON A/C A380-800

AIRBUS

A380-800

Aircraft Rescue and Fire Fighting Chart ARFC

NOTE:

**THIS CHART GIVES THE GENERAL LAYOUT OF THE A380-800 STANDARD VERSION.
THE NUMBER AND ARRANGEMENT OF THE INDIVIDUAL ITEMS VARY WITH THE CUSTOMERS.
FIGURES CONTAINED IN THIS POSTER ARE AVAILABLE SEPARATELY IN THE CHAPTER 10 OF THE
"AIRCRAFT CHARACTERISTICS - AIRPORT AND MAINTENANCE PLANNING" DOCUMENT.**

ISSUED BY:
AIRBUS S.A.S
CUSTOMER SERVICES
TECHNICAL DATA SUPPORT AND SERVICES
31707 BLAGNAC CEDEX
FRANCE

REVISION DATE: DECEMBER 2015
REFERENCE : L_RF_000000_1_A380800
SHEET 1/2

© AIRBUS S.A.S. 2012 . All rights reserved.

L_AC_100000_1_0010101_01_02

Front Page
FIGURE-10-0-0-991-001-A01

**ON A/C A380-800

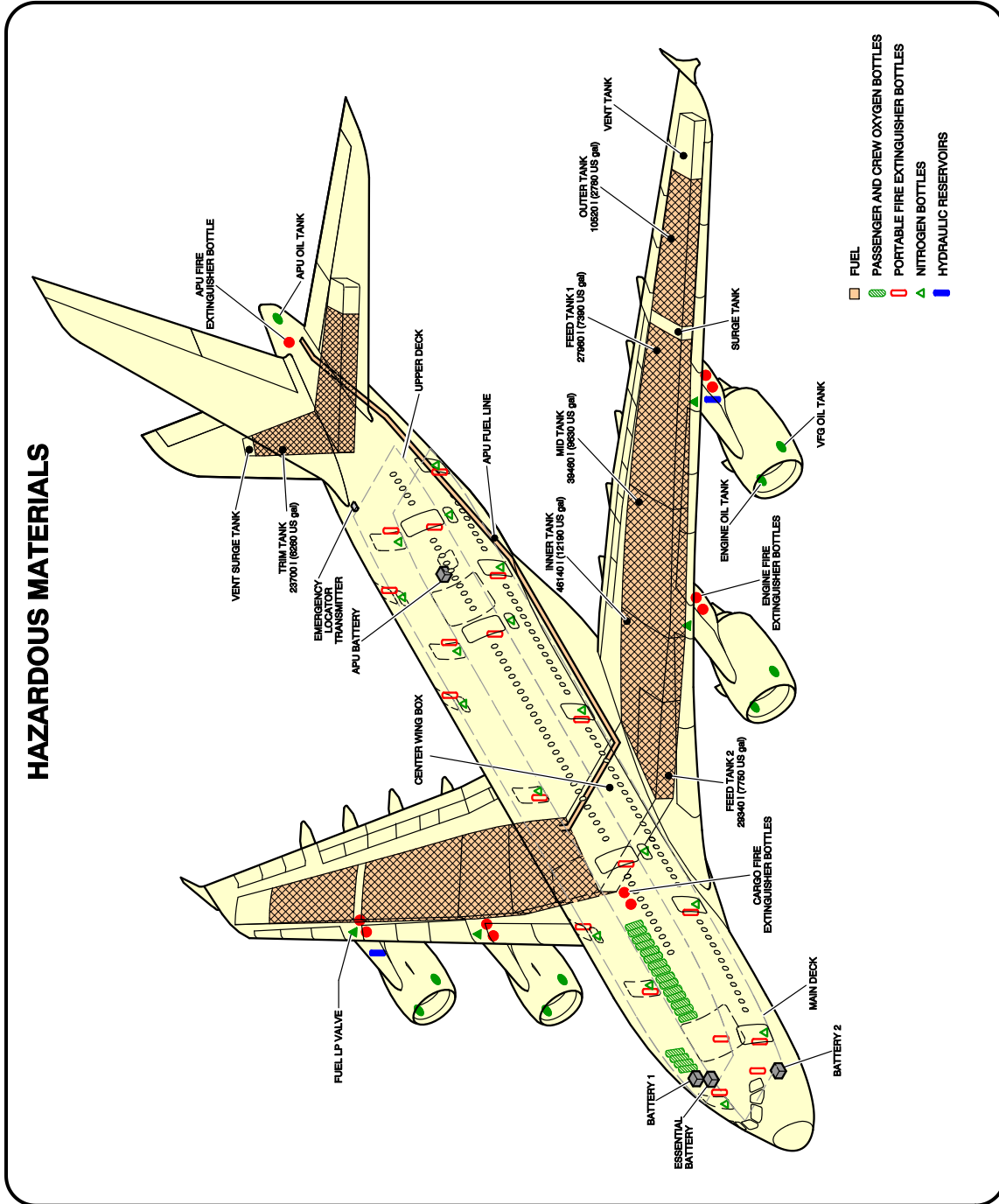

L_AC_100000_1_0020101_01_03

Highly Flammable and Hazardous Materials and Components
FIGURE-10-0-0-991-002-A01

**ON A/C A380-800

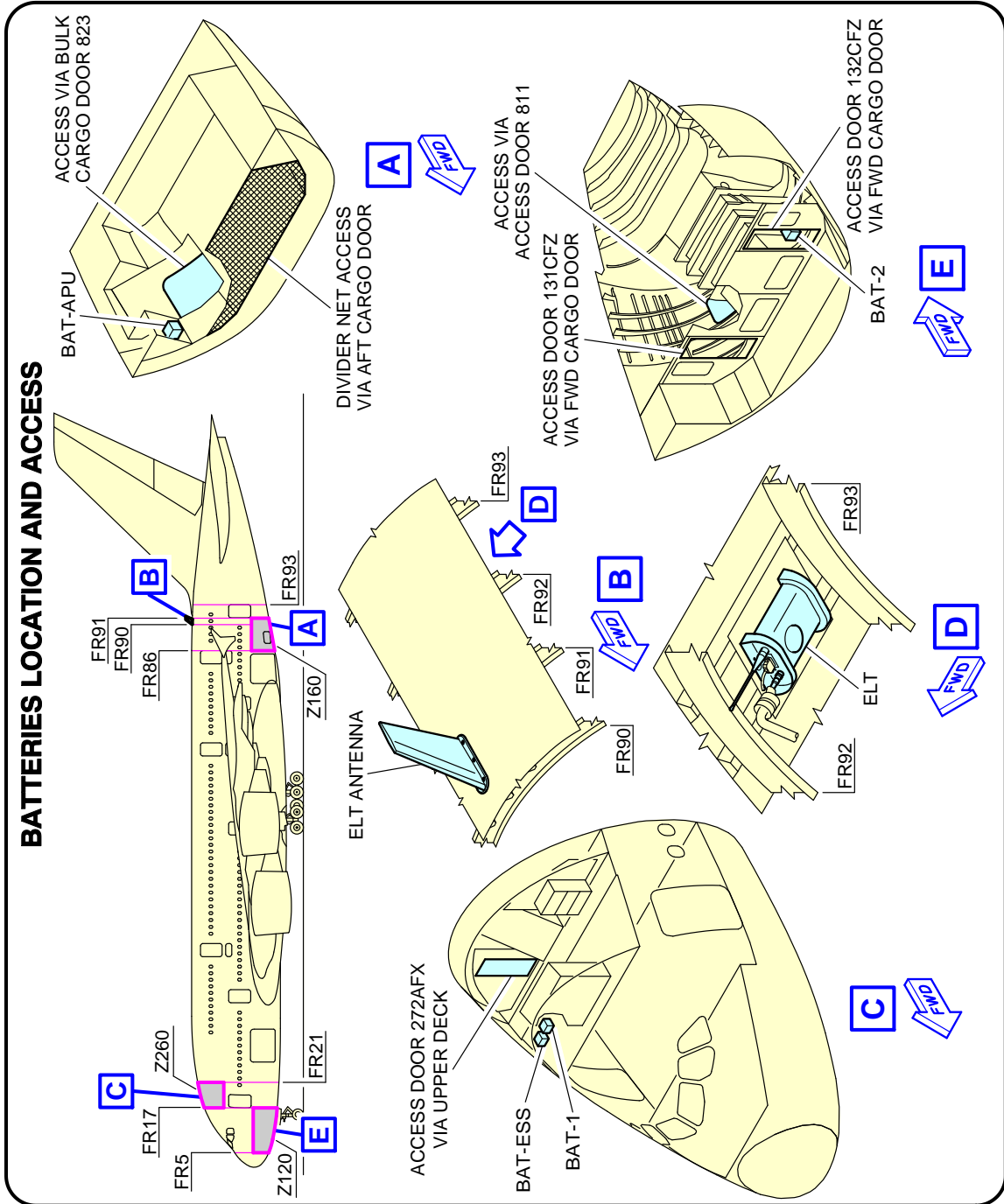

L_AC_100000_1_0170101_01_01

Batteries Location and Access
FIGURE-10-0-0-991-017-A01

**ON A/C A380-800

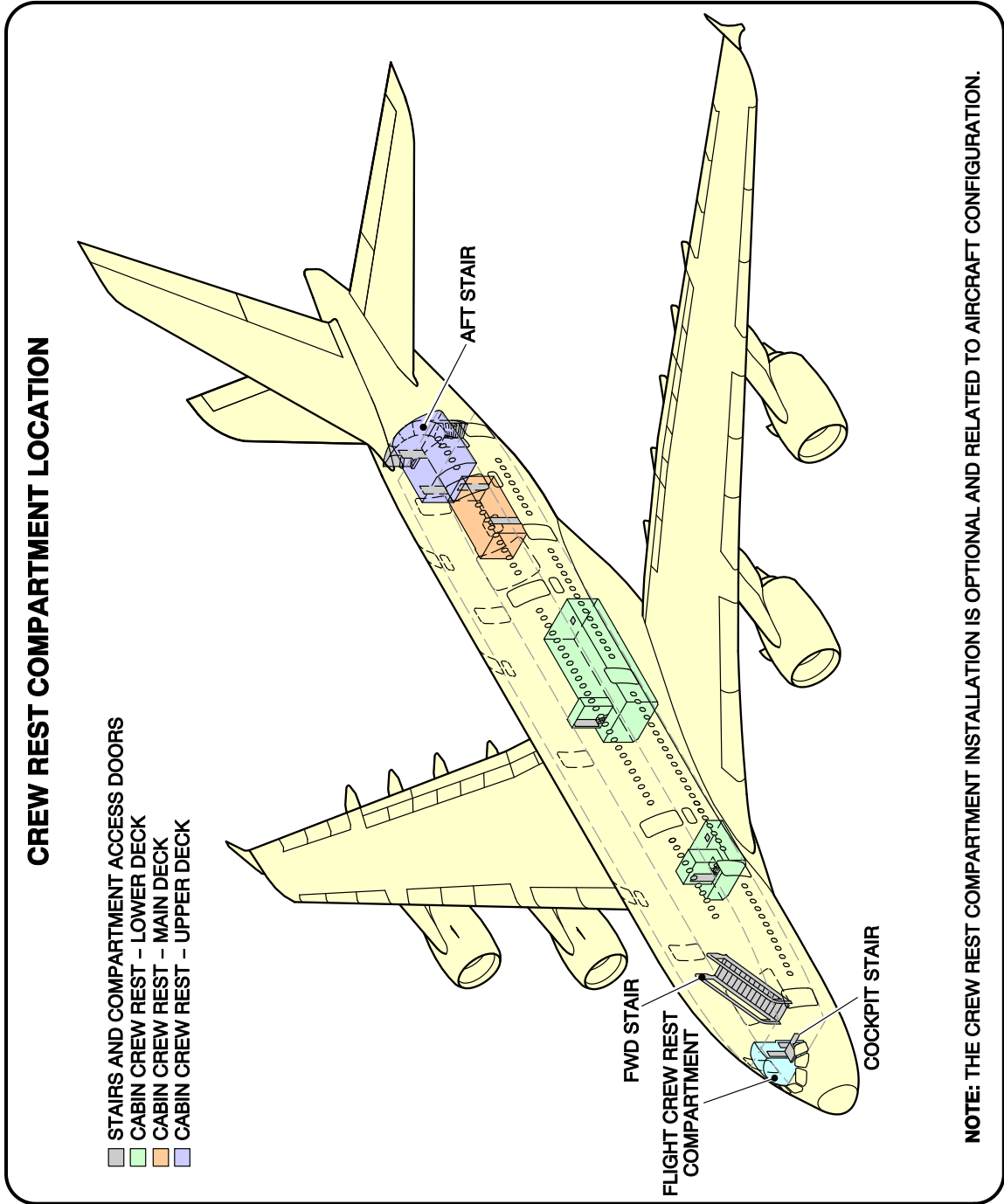

L_AC_100000_1_0160101_01_00

Crew Rest Compartments Location
 FIGURE-10-0-0-991-016-A01

****ON A/C A380-800**

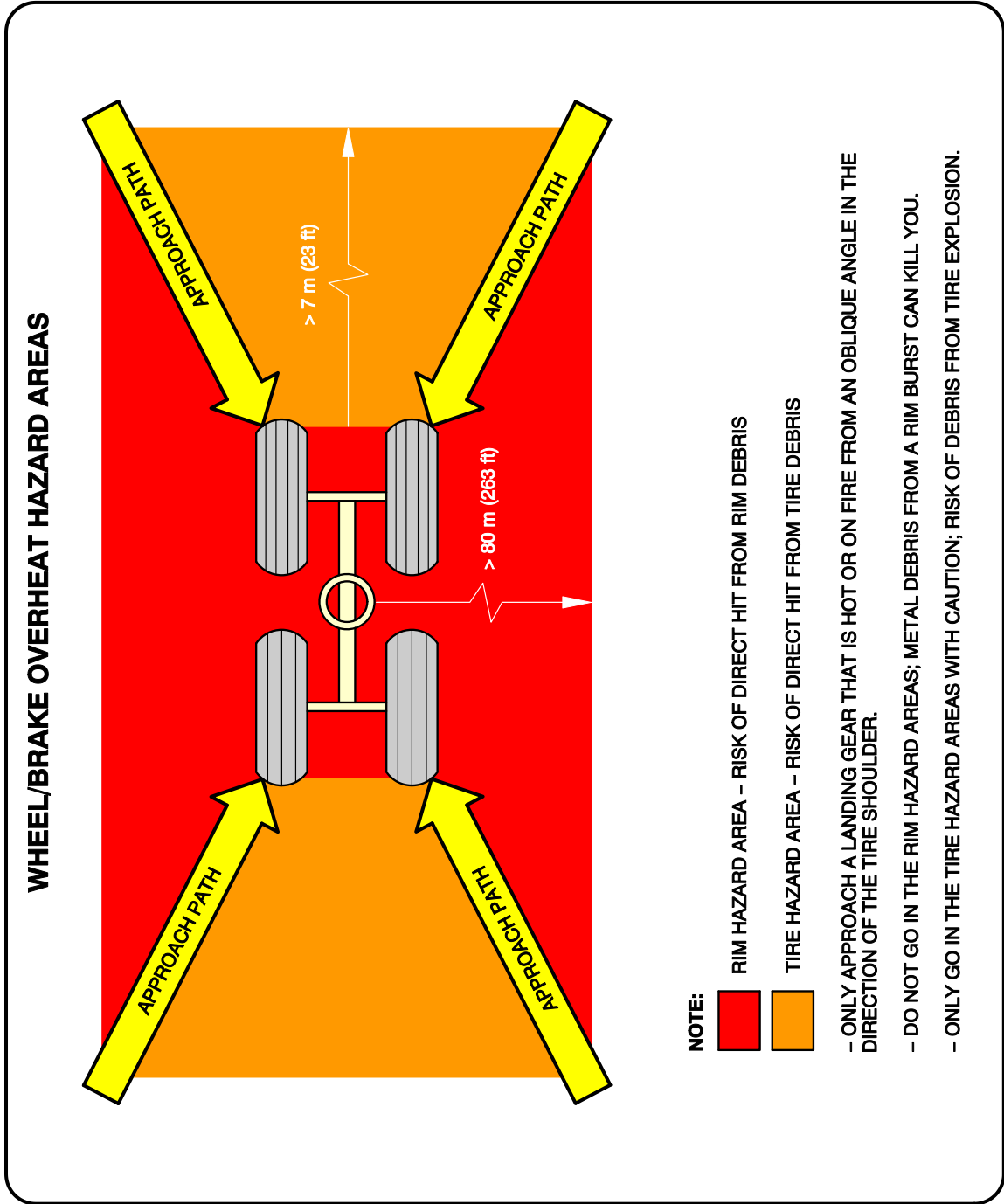

L_AC_100000_1_0140101_01_00

Wheel/Brake Overheat
 Wheel Safety Area (Sheet 1 of 2)
 FIGURE-10-0-0-991-014-A01

****ON A/C A380-800**

BRAKE OVERHEAT AND LANDING GEAR FIRE

WARNING: BE VERY CAREFUL WHEN THERE IS A BRAKE OVERHEAT AND/OR LANDING GEAR FIRE. THERE IS A RISK OF TIRE EXPLOSION AND/OR WHEEL RIM BURST THAT CAN CAUSE DEATH OR INJURY. MAKE SURE THAT YOU OBEY THE SAFETY PRECAUTIONS THAT FOLLOW.

THE PROCEDURES THAT FOLLOW GIVE RECOMMENDATIONS AND SAFETY PRECAUTIONS FOR THE COOLING OF VERY HOT BRAKES AFTER ABNORMAL OPERATIONS SUCH AS A REJECTED TAKE-OFF OR OVERWEIGHT LANDING. FOR THE COOLING OF BRAKES AFTER NORMAL TAXI-IN, REFER TO YOUR COMPANY PROCEDURES.

BRAKE OVERHEAT:

- 1 - GET THE BRAKE TEMPERATURE FROM THE COCKPIT OR USE A REMOTE MEASUREMENT TECHNIQUE. THE REAL TEMPERATURE OF THE BRAKES CAN BE MUCH HIGHER THAN THE TEMPERATURE SHOWN ON THE ECAM. **NOTE:** AT HIGH TEMPERATURES (>800°C), THERE IS A RISK OF WARPING OF THE LANDING GEAR STRUTS AND AXLES.
- 2 - APPROACH THE LANDING GEAR WITH EXTREME CAUTION AND FROM AN OBLIQUE ANGLE IN THE DIRECTION OF THE TIRE SHOULDER. DO NOT GO INTO THE RIM HAZARD AREA AND ONLY GO IN THE TIRE HAZARD AREA WITH CAUTION. (REF FIG. WHEEL/BRAKE OVERHEAT HAZARD AREAS). IF POSSIBLE, STAY IN A VEHICLE.
- 3 - LOOK AT THE CONDITION OF THE TIRES: IF THE TIRES ARE STILL INFLATED (FUSE PLUGS NOT MELTED), THERE IS A RISK OF TIRE EXPLOSION AND RIM BURST. DO NOT USE COOLING FANS BECAUSE THEY CAN PREVENT OPERATION OF THE FUSE PLUGS.
- 4 - USE WATER MIST TO DECREASE THE TEMPERATURE OF THE COMPLETE WHEEL AND BRAKE ASSEMBLY. USE A TECHNIQUE THAT PREVENTS SUDDEN COOLING. SUDDEN COOLING CAN CAUSE WHEEL CRACKS OR RIM BURST. DO NOT APPLY WATER, FOAM OR CO2. THESE COOLING AGENTS (AND ESPECIALLY CO2, WHICH HAS A VERY STRONG COOLING EFFECT) CAN CAUSE THERMAL SHOCKS AND BURST OF HOT PARTS.

LANDING GEAR FIRE:

- CAUTION:** AIRBUS RECOMMENDS THAT YOU DO NOT USE DRY POWDERS OR DRY CHEMICALS ON HOT BRAKES OR TO EXTINGUISH LANDING GEAR FIRES. THESE AGENTS CAN CHANGE INTO SOLID OR ENAMELED DEPOSITS. THEY CAN DECREASE THE SPEED OF HEAT DISSIPATION WITH A POSSIBLE RISK OF PERMANENT STRUCTURAL DAMAGE TO THE BRAKES, WHEELS OR WHEEL AXLES.
- 1 - IMMEDIATELY STOP THE FIRE:
 - A) APPROACH THE LANDING GEAR WITH EXTREME CAUTION FROM AN OBLIQUE ANGLE IN THE DIRECTION OF THE TIRE SHOULDER. DO NOT GO INTO THE RIM HAZARD AREA AND ONLY GO IN THE TIRE HAZARD AREA WITH CAUTION. IF POSSIBLE, STAY IN A VEHICLE.
 - B) USE LARGE AMOUNTS OF WATER. WATER MIST; IF THE FUEL TANKS ARE AT RISK, USE FOAM. USE A TECHNIQUE THAT PREVENTS SUDDEN COOLING. SUDDEN COOLING CAN CAUSE WHEEL CRACKS OR RIM BURST.
 - C) DO NOT USE FANS OR BLOWERS.

L_AC_100000_1_0140102_01_00

Wheel/Brake Overheat
 Recommendations (Sheet 2 of 2)
 FIGURE-10-0-0-991-014-A01

**ON A/C A380-800

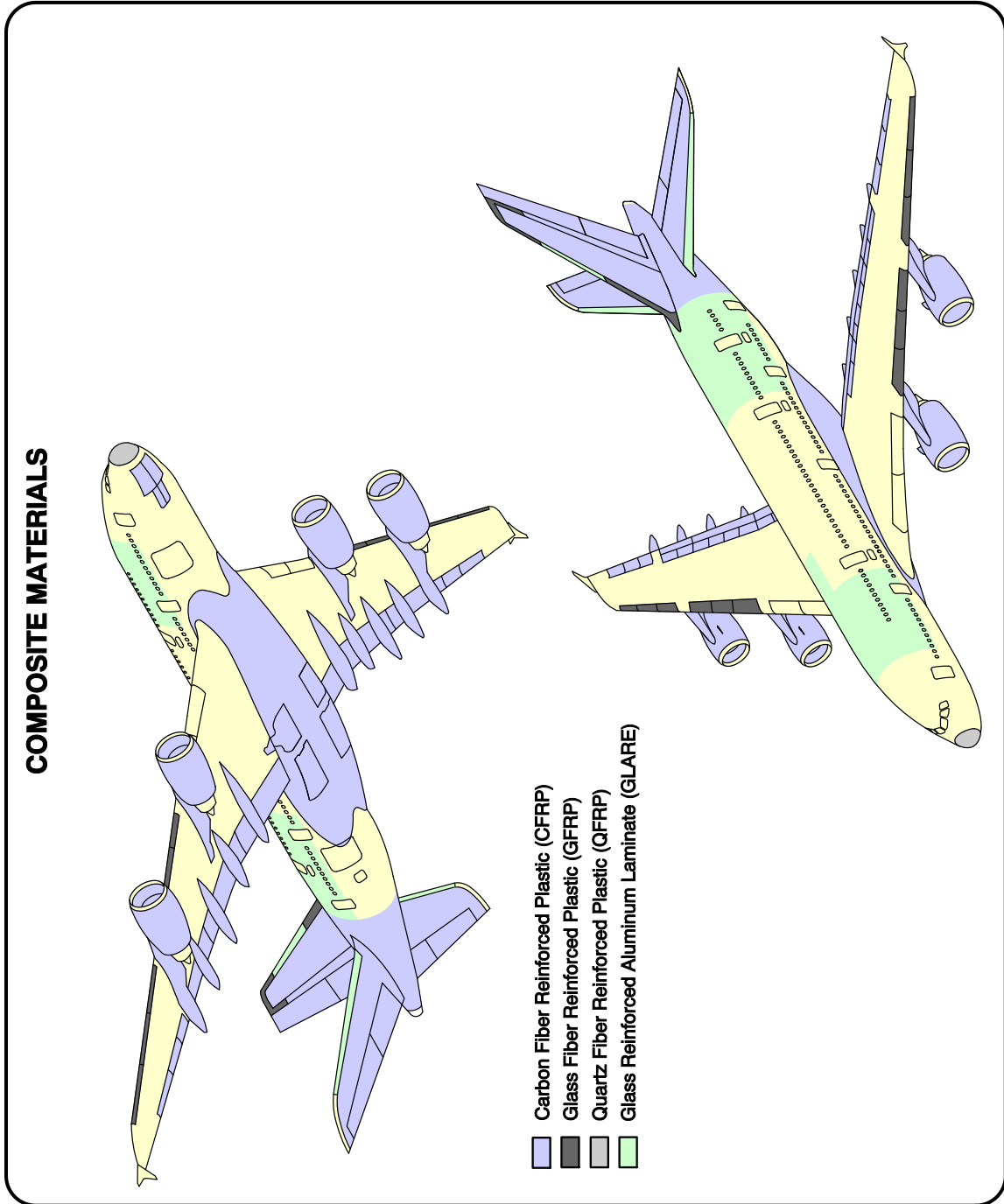

L_AC_100000_1_0030101_01_01

Composite Materials Location
FIGURE-10-0-0-991-003-A01

**ON A/C A380-800

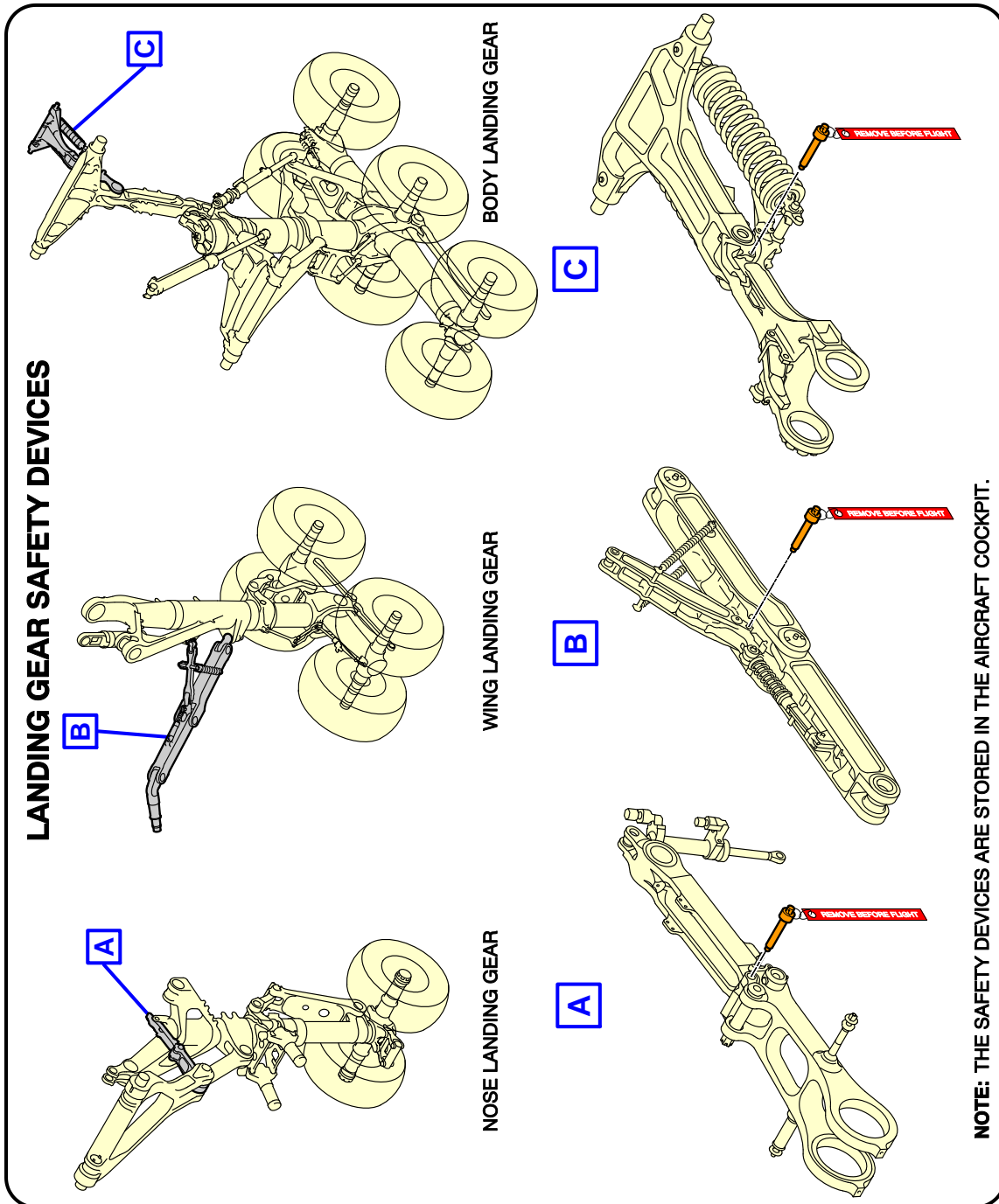

L_AC_100000_1_0040101_01_01

Landing Gear
Ground Lock Safety Devices
FIGURE-10-0-0-991-004-A01

****ON A/C A380-800**

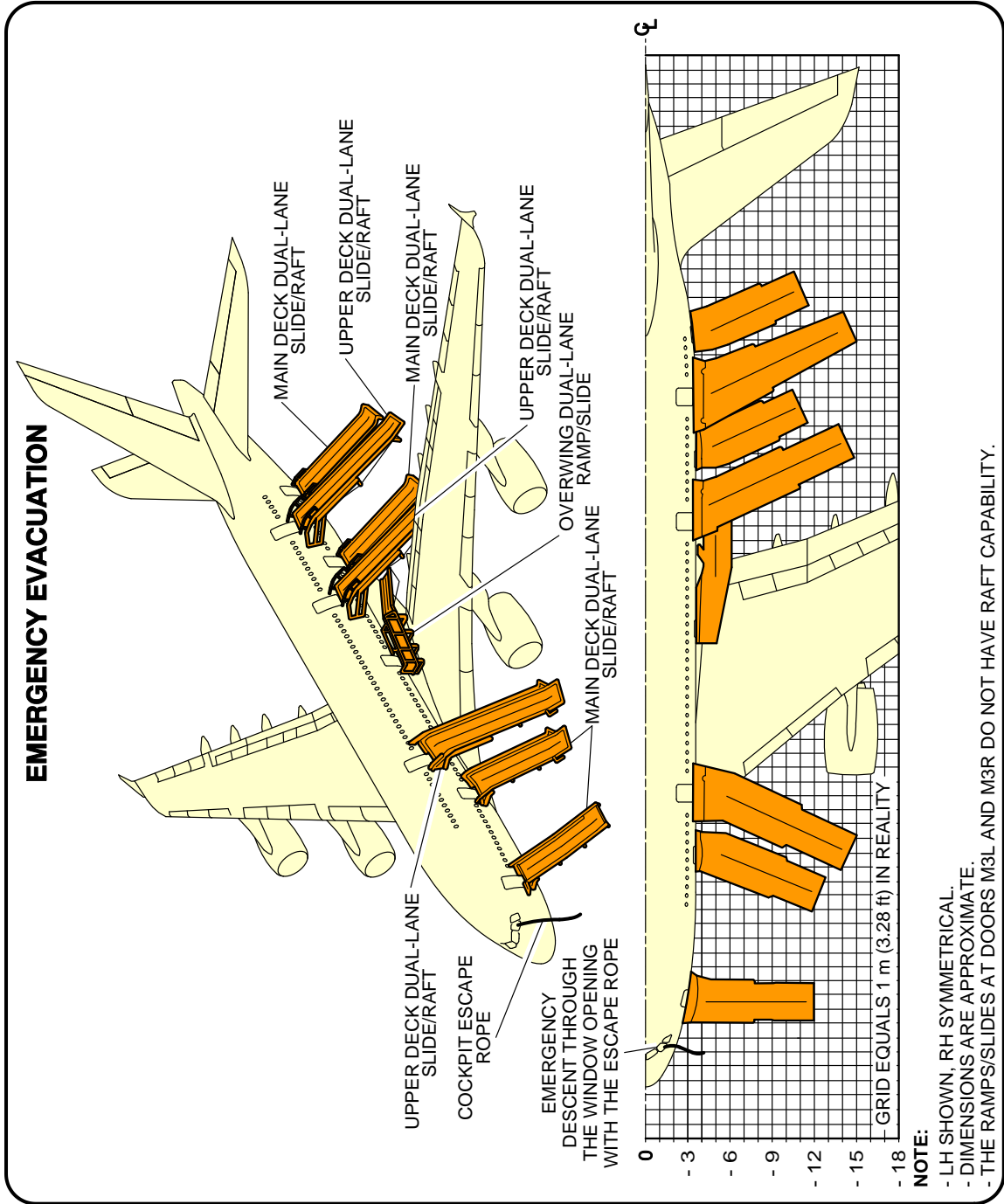

L_AC_100000_1_0050101_01_04

Emergency Evacuation Devices
FIGURE-10-0-0-991-005-A01

****ON A/C A380-800**

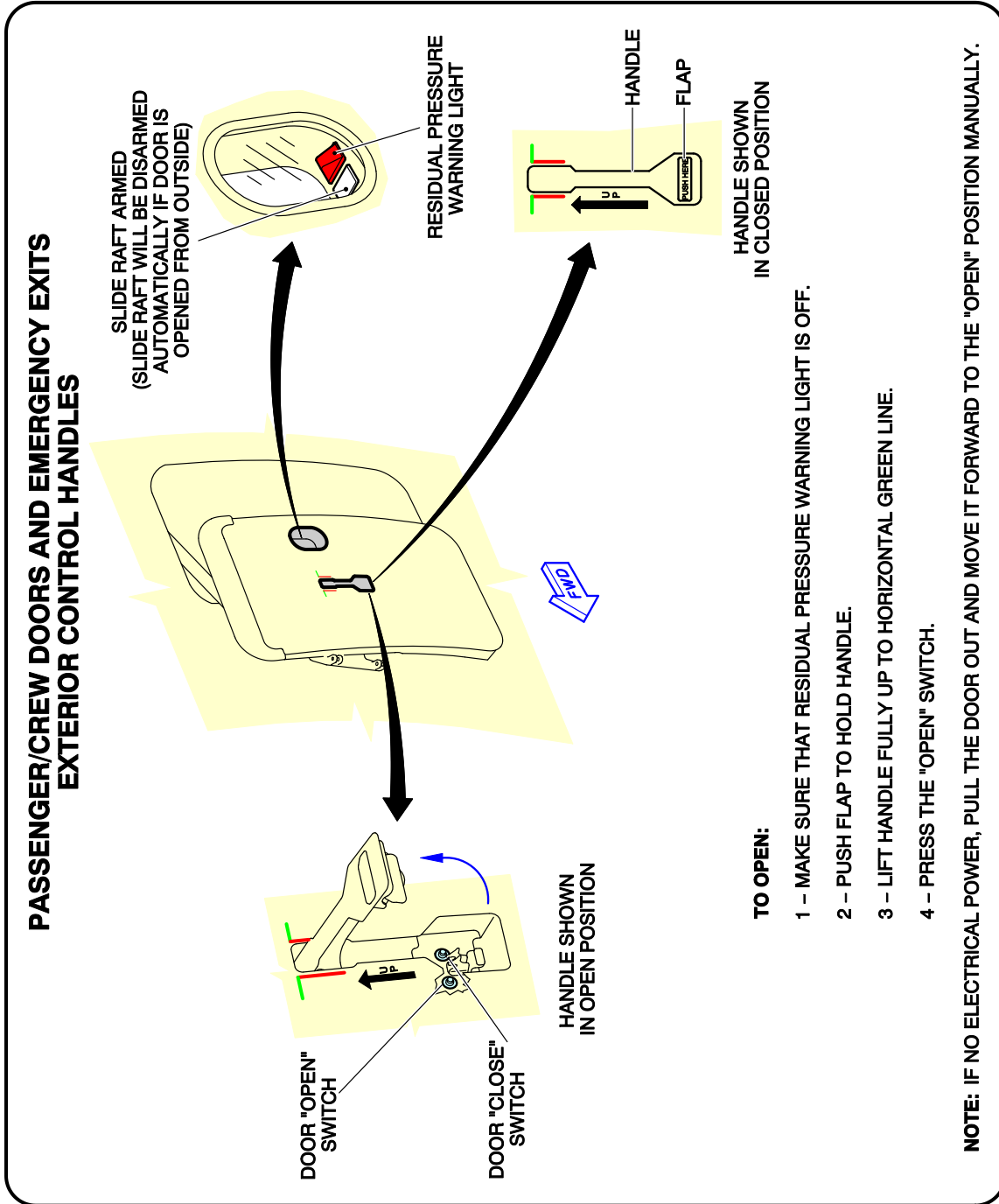

L_AC_100000_1_0060101_01_02

Pax/Crew Doors and Emergency Exits
FIGURE-10-0-0-991-006-A01

****ON A/C A380-800**

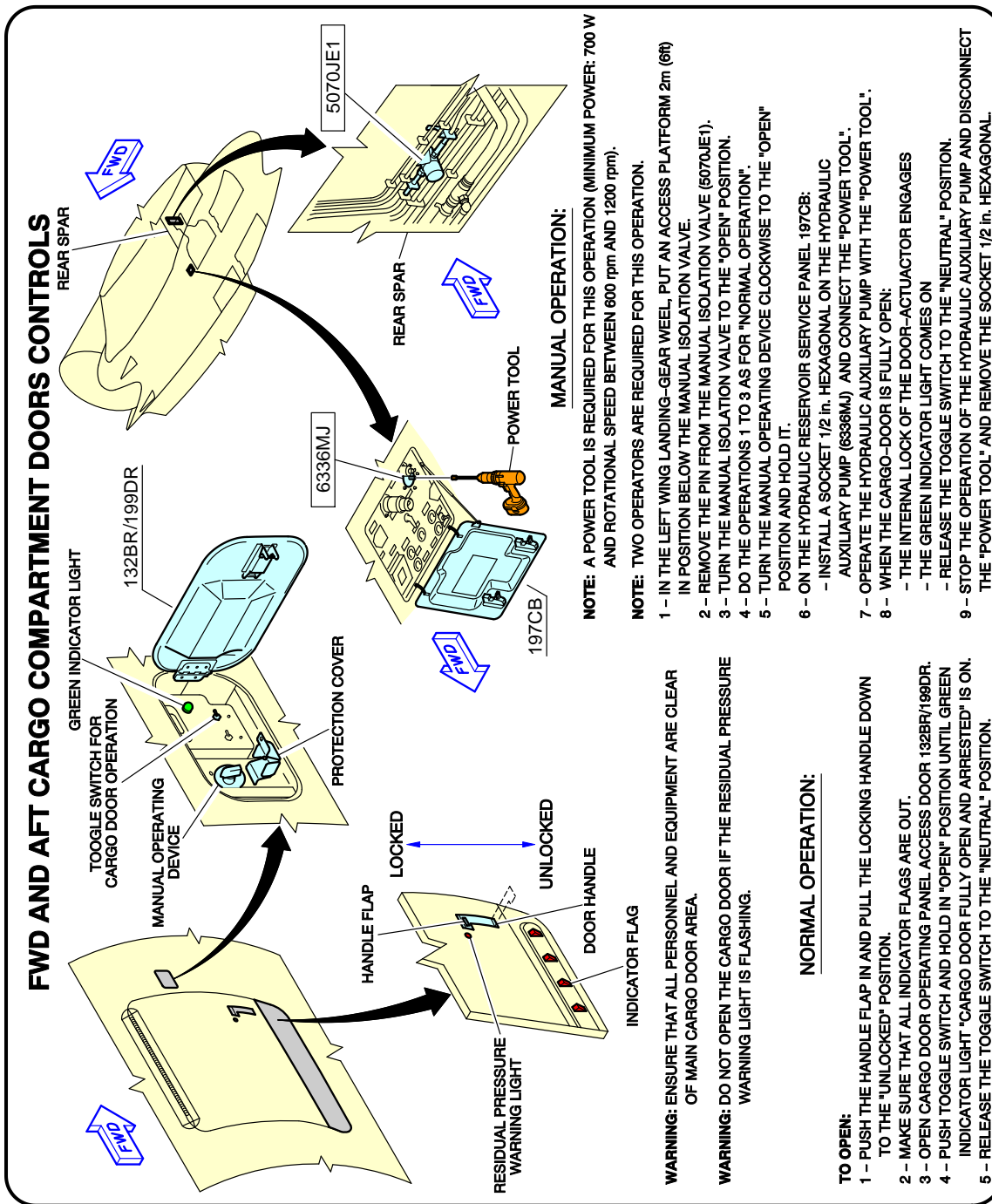

L_AC_100000_1_0070101_01_02

Cargo Doors
FWD and AFT Lower Deck Cargo Doors
FIGURE-10-0-0-991-007-A01

****ON A/C A380-800**

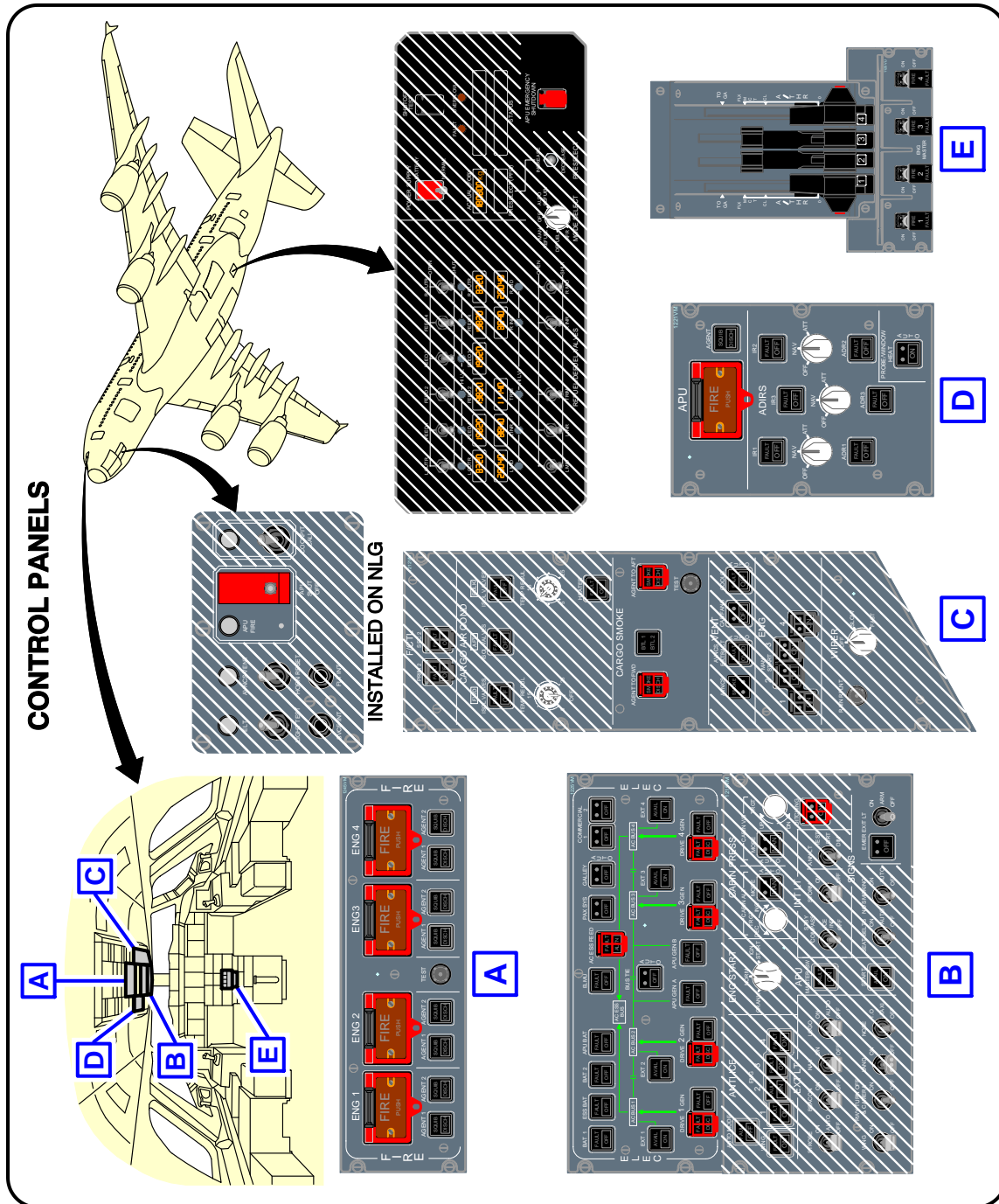

L_AC_100000_1_0100101_01_01

Control Panels
FIGURE-10-0-0-991-010-A01

****ON A/C A380-800**

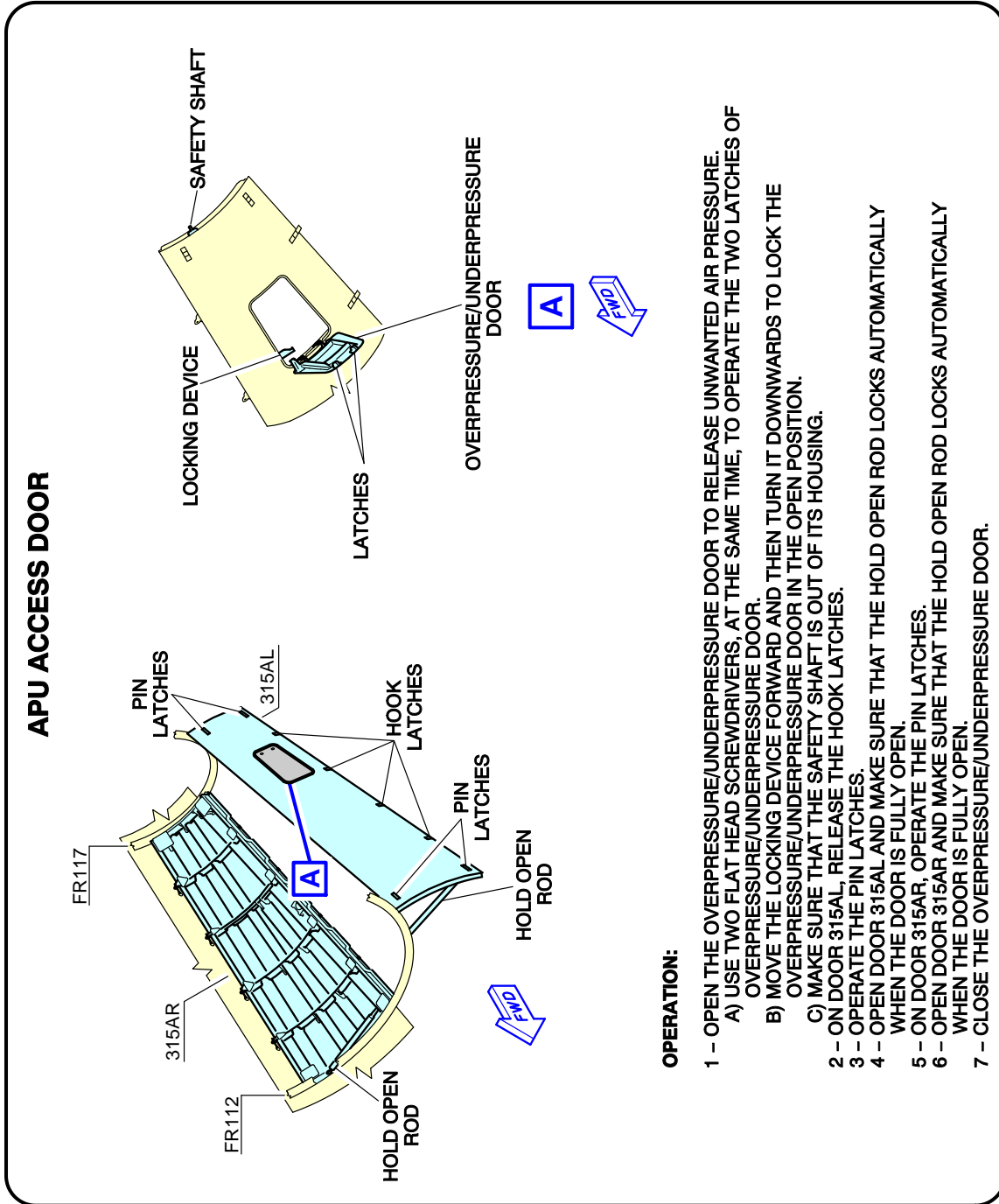

L_AC_100000_1_0110101_01_01

APU Compartment Access
FIGURE-10-0-0-991-011-A01

**ON A/C A380-800

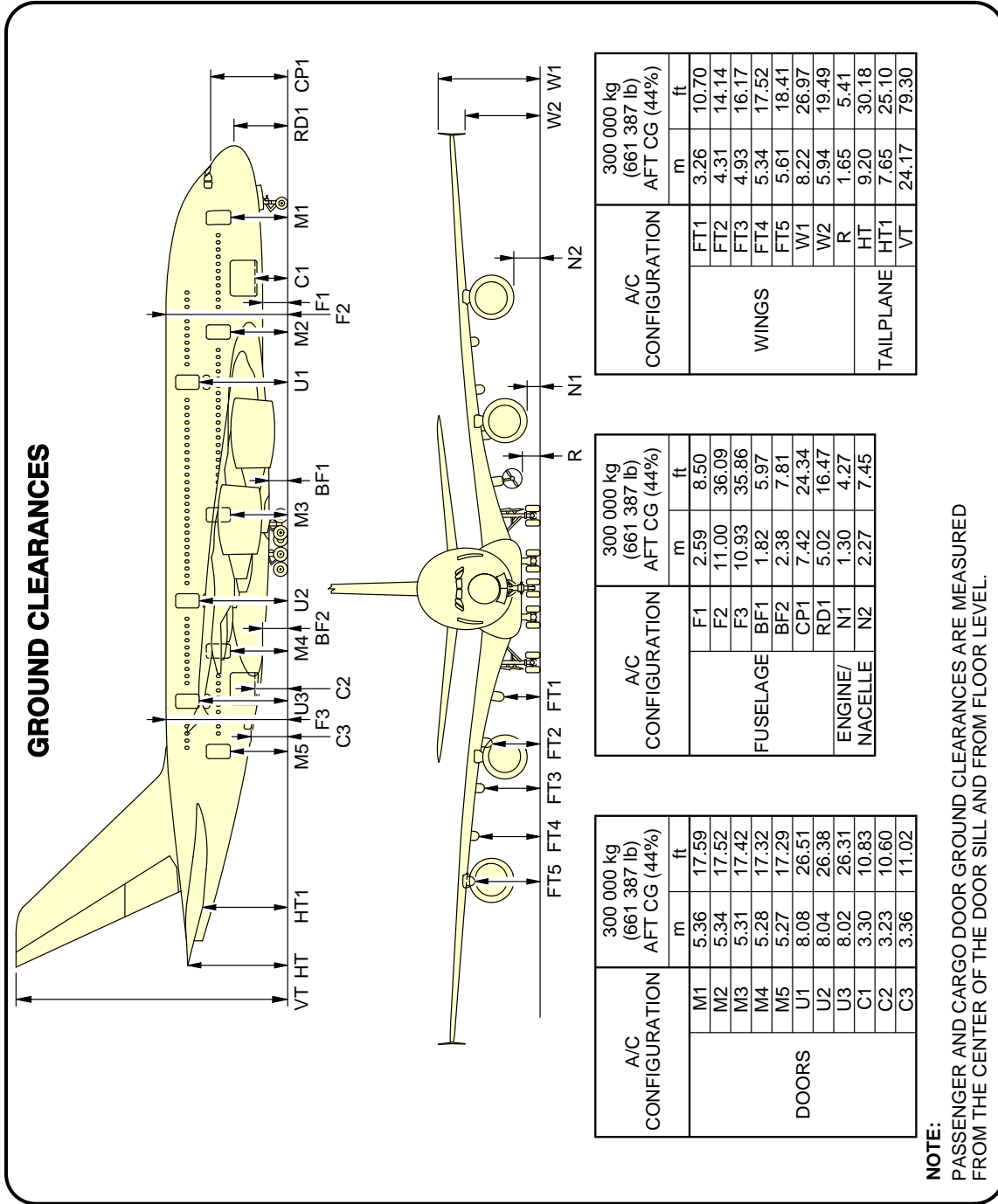

L_AC_100000_1_0120101_01_02

Aircraft Ground Clearances
FIGURE-10-0-0-991-012-A01

****ON A/C A380-800**

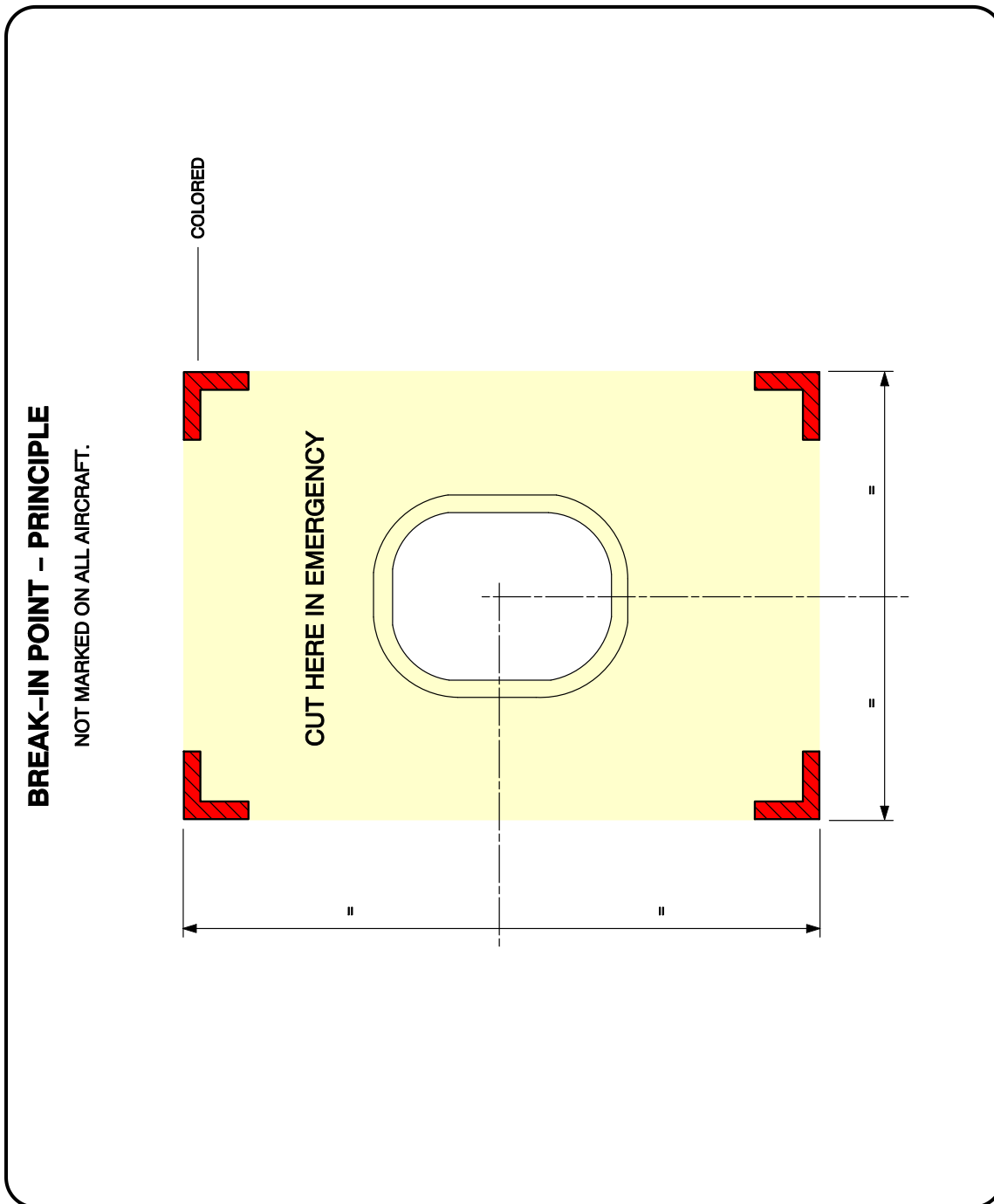

L_AC_100000_1_0130101_01_02

Structural Break-in Points
FIGURE-10-0-0-991-013-A01